



International Journal of Advanced Research in Electrical, Electronics and Instrumentation Engineering

(A High Impact Factor, Monthly, Peer Reviewed Journal)

Website: www.ijareeie.com

Vol. 9, Issue 3, March 2020

Review on Grid Connected Solar Wind Hybrid Power Based IOT System

Ashirwad Dubey¹, Abhishek Tripathi²

Department of Electrical Engineering, ITM University, Gwalior, India^{1,2}

ABSTRACT: As demand of electricity is increasing, use renewable energy sources to generate more amount of energy in the industries and home appliances is also increasing. The solar and wind hybrid generation system are economical, freely available in the environment. The two main reason to design solar and wind hybrid generation system using the renewable energy source are power reliability in varying weather condition and cost. In the proposed system, we are introducing the reliability to deliver continuous supply of load and monitoring it with IOT interfacing. The system consists of a wind turbine, PV solar, charge controller, battery, inverter, grid and IOT system for monitoring electrical parameters of the system. Advantage of IOT system is that the operator can know the updated electrical parameters from anywhere and anytime.

KEYWORDS: Solar Panel, Windmill, IOT system, inverter, Renewable Energy.

I. INTRODUCTION

The increasing demand for conventional energy sources like coal, natural gas and oil is forcing people towards the research and development of renewable energy sources or non-conventional energy sources. Renewable energy is energy that is collected from renewable resources, which are naturally replenished on a human timescale, such as sunlight, wind, rain, tides, waves, and geothermal heat. Hybrid energy system is the combination of two energy sources for giving power to the load. In other word it can defined as “Energy system which is fabricated or designed to extract power by using two energy sources is called as the hybrid energy system.” Hybrid energy system has good reliability, efficiency, less emission, and lower cost. Hybrid energy system is combination of two or more renewable energy sources like wind, solar hydro, etc. This provide clean and eco-friendly energy. Due to extreme development in renewable energy technologies and continuously rise in prices of petroleum products, hybrid renewable energy system are gaining more importance of supplying the power to meet the today’s increasing energy demand. This hybrid system can be standalone or can be grid connected. The grid connected hybrid system is more reliable to deliver continuous power because if there is any shortage of power or fault in the renewable energy sources then the load are directly connected to the grid. A wind turbine converts mechanical energy into electrical energy and it produces output voltage and these AC voltage is converted to DC by the help of AC to DC converter or rectifier. The PV cells converts light energy into electrical energy and produces DC output voltage. Solar cell can generate the electricity required in day while wind turbine can compensate the needs in the night by wind energy. The system consists of a wind turbine, a PV solar, charging controller, battery, inverter to convert DC to AC of grid and IOT system for monitoring electrical parameters of system. Advantage of IOT system is that the operator can know the updated electrical parameters from anywhere and anytime.

II. LITERATURE REVIEW

The purpose of the project is to get reliable electricity from the solar wind hybrid generation system to the user with uninterrupted electrical power supply, with affordable cost without damaging the natural balance. Maintenance of power plant management is provided at the Centre through remote monitoring by using measuring sensor installed at power plant and as regular check-up or repair being performed at site is progressed by site management personnel. But there is a difference in time and accuracy depending on the ability of site management personnel. This drawback is



International Journal of Advanced Research in Electrical, Electronics and Instrumentation Engineering

(A High Impact Factor, Monthly, Peer Reviewed Journal)

Website: www.ijareeie.com

Vol. 9, Issue 3, March 2020

overcome by managing hybrid power system using (INTERNET OF THINGS, IOT). It may be expanded to a technology of recognizing other power generation facility in the future. The result will obtain for both economic and various environmental condition. . In this paper, the solar wind hybrid generation system is lead to generate electricity with affordable cost without damaging the nature. This paper deals with the generation of electricity by using two sources combine which leads to generate electricity with affordable cost without damaging the nature balance. Solar energy has drawback that it could not produce electrical energy in rainy and cloudy season so we need to overcome this drawback we can use two energy resources so that any one of source fails other source will keep generating the electricity. And in good weather condition we can use both sources combine. The idea of this paper is to get current state and future state of solar wind hybrid generation system and its utilization to the rural areas, villages, industries home appliances and to develop local area.

The hybrid generation system can be used to store renewable energy sources. Economic aspects of these renewable energy technologies are sufficiently promising to include them for rising power generation capability in developing countries, these hybrid energy systems are becoming popular in remote area power generation applications due to advancements in renewable energy and development efforts in solar, wind, and other renewable energy technologies are required to continue for, improving their performance, establishing techniques for accurately predicting their output and reliably integrating them with other conventional generating sources. The aim of this paper is to review the current state of the design, operation and control requirement of the stand-alone PV solar-wind hybrid energy systems with conventional backup source. This Paper also highlights the future developments, which have the potential to increase the economic attractiveness of such systems and their acceptance by the user. The concept of this paper develops the system optimization sizing. It also consists of three parts the model of hybrid system, the model of Loss of Power Supply Probability (LPSP) and the model of the Levelised Cost of Energy (LCE), which levelised the cost of hybrid system. It will used to optimize the capacity sizes of different component of solar wind hybrid generation system and also the power generation system can be achieved technically and economically according to the system reliability requirements. In order to efficiently and economically utilize renewable energy resources of wind and solar energy applications, the optimum match design sizing is very important for solar-wind power generation systems with battery banks, there exist instability shortcomings for electric power production from photovoltaic (PV) modules and wind turbines.

III. BLOCK DIAGRAM

The Grid Connected Solar Wind Hybrid Power Based IOT System consists of following blocks-

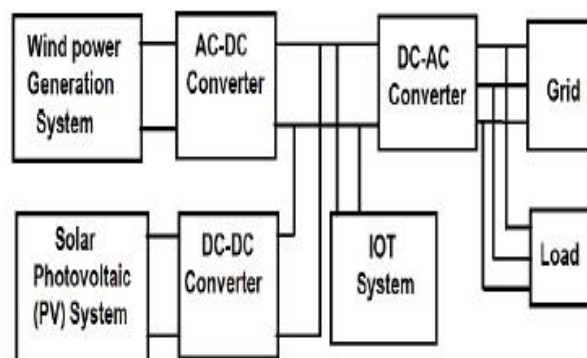

3.1 Solar Panel:

Solar power is the cleanest , most reliable form of energy available ,and it can be use in several forms to help power your home or industries. Solar powered photovoltaic (PV) panels convert the sun rays into electrical energy by exciting electrons in silicon cells using the photons of light from the sun. Most of the solar panels placed on the roof to get sun



International Journal of Advanced Research in Electrical, Electronics and Instrumentation Engineering

(A High Impact Factor, Monthly, Peer Reviewed Journal)

Website: www.ijareeie.com

Vol. 9, Issue 3, March 2020

rays on panel. The solar panels also known as modules contain photovoltaic cells made from silicon that transform incoming sunlight into electricity than heat. The energy of solar depends on the installation panel on home and industries.

3.2 Windmill :

Wind power converts the kinetic Energy in wind to generated electricity or mechanical power. There are currently two different kinds of wind turbines horizontal axis wind turbines (HAWT) and vertical axis wind turbines (VAWT). Converting wind to mechanical energy wind is converted by the blades of wind turbines. The HAWT are the most common displaying the propeller or 'fan-style' blades and VAWT are usually in an 'egg-beater' style blades.

3.3 Charging Controller:

A charge controller, charge regulator or battery regulator limits the rate at which electric current is added to or drawn from electric batteries. It prevents over charging and may protect against over voltage which can reduce battery performance or lifespan. And safety risk. It is used to maintain the proper charging voltage on the batteries.

3.4 Inverter: Inverter is an electronic device or circuitry that changes direct current (DC) to alternating current (AC). A typical power inverter device or circuit requires a relatively stable DC power source capable of supplying enough current for the intended power demand. An inverter can produce a square wave, modified sine wave, pulse width modulation (PWM).

3.5 Grid: An electrical grid is an interconnected network for delivering electricity from producers to consumers. It consists of generating stations that produce electrical power, high voltage transmission lines that carry power from distant sources to demand centers, and distribution that connect individual customers.

3.6 IOT System :

The internet of things (IOT) is the network of physical devices, vehicles home appliances and other items embedded with electronics software, sensors, actuators and connectivity which enables these objects to connect and exchange data.

4. Advantages of renewable hybrid Power system:

1. No pollution.
2. Clean and pure energy.
3. Long term warranty.
4. Long term sustainability.
5. Cost saving.
6. Provide uninterrupted power supply to the equipment.
7. Efficient and easy installation longer life.
8. Low maintenance cost (there is nothing replace).
9. Very high reliability.
10. Operational in all weather.
11. Can be used for 24-hour power generation.

5. Rebates & Tax Credits

A federal tax credit is available for solar energy systems. The credit is for 30% through 2019, then decreases to 26% for tax year 2020, then to 22% for tax year 2021. It expires December 31, 2021. The federal tax credit for small wind energy systems expired at the end of 2016. If you installed a small wind system in 2015 or 2016.



ISSN (Print) : 2320 – 3765
ISSN (Online): 2278 – 8875

International Journal of Advanced Research in Electrical, Electronics and Instrumentation Engineering

(A High Impact Factor, Monthly, Peer Reviewed Journal)

Website: www.ijareeie.com

Vol. 9, Issue 3, March 2020

IV. CONCLUSION

In the present work a solar PV Wind Hybrid Energy System was implemented. A portion of the energy requirement for a private house, farm house, a small company, an educational institution or an apartment house depending on the need at the site where use has been supplied with the electricity generated from the wind and solar power. It reduces the dependence on single source and has a increased reliability. Hence we could improve the efficiency of the system as compared with their individual mode of generation.

A small "hybrid" electric system that combines wind electric and solar electric (photovoltaic cell) technologies offers several advantages over either single system. We know that wind speeds are low in the summer when the sun shines brightest and longest. The wind is strong in the winter when less sunlight is available. Because the peak operating times for wind and solar systems occur at different times of the day and year, hybrid systems are more likely to produce power when you need it. Many hybrid systems are stand-alone systems, which operate "off-grid" -- not connected to an electricity distribution system. For the times when neither the wind nor the solar system are producing, most hybrid systems provide power through batteries and/or an engine generator powered by conventional fuels, such as diesel. If the batteries run low, the engine generator can provide power and recharge the batteries. Adding an engine generator makes the system more complex, but modern electronic controllers can operate these systems automatically. An engine generator can also reduce the size of the other components needed for the system. Keep in mind that the storage capacity must be large enough to supply electrical needs during non-charging periods. Battery banks are typically sized to supply the electric load for one to three days.

REFERENCES

- [1] Kalaiarasi. D, A. Anusha, "Enhancement Of Hybrid Power System Using IOT," in the International Journal of the Advanced Research Trends in Engineering and Technology (IJARTET) ,Vol 3,Special Issue 19 ,April 2016.
- [2] Ashish. S. Ingole, Roshan. S. Rakhonde "Hybrid Power Generation System using Wind energy and Solar energy,"in International Journal of Scientific and Research Publications, Volume 5, Issue 3, March 2015 1, ISSN 2250-3153.
- [3] Pragya Nema, Saroj Rangnekar "A current and future state of art development of hybrid energy system using wind and PV-solar "in November 2008.
- [4] Wei Jhou, Hoxing Yang "A Novel Optimization sizing model for hybrid solar-wind power generation system" in International Journal in, vol. 81, Number 1. 2007