



Review on Estimation Techniques for MIMO-OFDM

Jitendra Singh¹, Devendra Dohare²

PG Student, Dept. of Instrumentation & Control Engg., Maharana Pratap College of Technology, Gwalior, M.P, India¹

Professor, Dept. of Electrical Engineering, Maharana Pratap College of Technology, Gwalior, M.P, India²

ABSTRACT: In the context of Third-Generation Partnership Project Long-Term Evolution (3GPP LTE), the target data rates are 100 Mb/s in downlink and 50 Mb/s in uplink, and other system features include flexible bandwidths and moderate power consumption of mobile terminals. While the previous 3GPP generations, namely, 3G UMTS and 3.5G HSPA, rely on code-division multiple access (CDMA), LTE adopts orthogonal frequency-division multiple access (OFDMA)-based technologies for its uplink and downlink. Due to high peak-to-average power ratio (PAPR) of OFDMA signals, the single-carrier frequency division multiple access (SC-FDMA), also known as discrete Fourier transform (DFT)-spread OFDMA, has been selected for the uplink transmission in 3GPP LTE systems. SC-FDMA has similar throughput performance as OFDMA but with lower PAPR to increase power efficiency and is less sensitive to frequency synchronization errors, which makes it favorable for mobile terminals.

KEYWORDS: Mean square error, least square, compressed sensing, channel estimation, block error rate. Multiple Input Multiple Output (MIMO), MIMO-OFDM (multiple input multiple output- orthogonal frequency division multiplexing).

I.INTRODUCTION

In MIMO system, multiple numbers of transmitters at one end and multiple numbers of receivers at the other end are effectively combined to improve the channel capacity of wire-less system. This technology highly improves the spectrum efficiency, reliability of system & coverage area. A simple MIMO-OFDM system shown in figure 1.

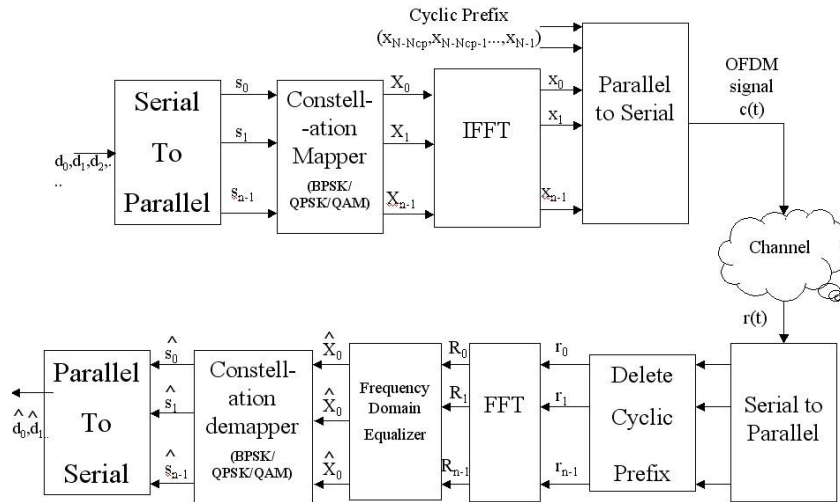

Figure.1: Block Diagram of MIMO OFDM System

II.LITERATURE REVIEW

In 2004, Garden L. Stuber [6] discussed a number of physical layer issues relevant for the implementation of broadband MIMO-OFDM systems. They discussed space time coding strategies for closed loop MIMO-OFDM systems where knowledge of the channel is available at the transmitter. Error-correction coding was discussed with an emphasis on high



rate LDPC codes. Adaptive analog beam forming techniques were discussed that can provide the best possible MIMO channel environment.

In 2006, Toufique Islam [5] presented multiuser channel estimation technique for space time block coded orthogonal frequency division multiplexing (STBC-OFDM) systems Based on simple blocked pilot grid. The estimation of multiuser channels are based on least square (LS) and Minimum mean square estimation (MMSE) schemes. The simulation result shows that for a slowly faded quasi-static channel estimated characteristics closely agree with the actual channel characteristics. Different Doppler fading effects on MMSE performance are also presented.

In 2009, Y. Mlayes [7] investigate an extra processing added to conventional LS estimation to improve its performance in MIMO-OFDM systems. The new technique proposed is based on knowledge of the power delay profile. The application of the improved estimator is useful when employing advanced MIMO adaptation techniques. Simulation results showed performance of MIMO techniques closed to that offered by perfect channel.

In 2011, Zangjie et al. [8] presents a simulation model of MIMO-OFDM system based on STBC which built and transmission performances under different channels are analyzes. The simulation results show that the MIMO-OFDM system based on STBC outperforms other MIMO-OFDM system without STBC in BER performance.

In 2013, Andre Antonio dos Anjos [8] addressed the problem to perform accurate channel estimation. They presented some channel estimation techniques that can be used in MIMO-OFDM systems that designed for diversity gain. The influence of interpolation technique on channel estimation error and MER has been analyzed. Different channels with different delay profiles have also been analyzed. A linear relationship between channel estimation error and the MER has been proposed.

In 2014, Melli, X.Wang, K.Zang [10] analyzed the least mean square (LMS) and Recursive least square (RLS) algorithms. They applied these two algorithms to MIMO-OFDM system based on space time block coding (STBC).From the simulation results it is found that the RLS is better than LMS algorithm. They showed the practical aspect of analyzed scheme in MATLAB environment.

In 2015, Istdeo Singh, Sheetal Kalyani, and K. Giridhar [12] Compressed sensing (CS) algorithms for orthogonal frequency division multiplexing (OFDM) channel estimation work best when the pilot subcarrier locations are pseudo random. However, wireless standards such as LTE typically have equi-spaced pilot structures on the downlink to also enable the estimation of various other signal parameters. Here, we propose an iterative CS algorithm for channel estimation in OFDM systems which work well even in the presence of equi-spaced pilots.

In 2016, Adnan Kiayani, Student Member, IEEE, Lauri Anttila, Member, IEEE, Yaning Zou, Member, IEEE, and Mikko Valkama, Member, IEEE [13], we analyze the effects of these radio impairments in a multiuser SC-FDMA uplink system and present digital-signal-processing based methods for the joint estimation and equalization of impairments and channel distortions on the receiver side with an arbitrary number of receiver antennas. For the equalization, linear equalizers such as the zero-forcing (ZF) and the minimum mean square error (MMSE) equalizers that utilize pairs of mirror subcarriers are formulated, and the MMSE equalizer is developed to effectively handle mirror subband users with different power levels. Furthermore, for reduced computational complexity, the joint channel and impairment filter responses are efficiently approximated with polynomial-based basis function models.

III.SYSTEM MODEL

In an MIMO-OFDM system, the transmitter modulates the message bit sequence into QAM symbols, performs IFFT on the symbols to convert them into time-domain signals, and sends them out through a (wireless) channel. The received signal is usually distorted by the channel characteristics. In order to recover the transmitted bits, the channel effect must be estimated and compensated in the receiver. The orthogonality allows each subcarrier component of the received signal to be expressed as the product of the transmitted signal and channel frequency response at the subcarrier. Thus, the transmitted signal can be recovered by estimating the channel response just at each subcarrier. In general, the channel can be estimated by using a preamble or pilot symbols known to both transmitter and receiver, which employ various interpolation



techniques to estimate the channel response of the subcarriers between pilot tones. In general, data signal as well as training signal, or both, can be used for channel estimation.

A generic block diagram of a basic baseband-equivalent MIMO-OFDM system is given in Fig. 2. A MIMO-OFDM system with N_{tx} transmit and N_{rx} receive antennas is assumed. The information bits can be coded and interleaved. The coded bits are then mapped into data symbols depending on the modulation type. Another stage of interleaving and coding can be performed for the modulated symbols. Although the symbols are in time domain, the data up to this point is considered to be in the frequency domain. The data is then demultiplexed for different transmitter antennas. The serial data symbols are then converted to parallel blocks, and an IFFT is applied to these parallel blocks to obtain the time domain OFDM symbols. For the transmit antenna, tx, time domain samples of an OFDM symbol can be obtained from frequency domain symbols as

$$\begin{aligned}
 x_{tx}[n, m] &= IFFT \{ X_{tx}[n, k] \} \\
 &= \sum_{k=0}^{K-1} X_{tx}[n, k] e^{j2\pi mk/K} \quad 0 \leq k, m \leq K - 1
 \end{aligned}
 \tag{1}$$

Where $X_{tx}[n, k]$ is the data at the k_{th} subcarrier of the n_{th} OFDM symbol, K is the number of subcarriers and m is the time domain sampling index.

The channel at time t is expressed as,

$$h(t, \tau) = \sum_{l=0}^{L-1} \alpha_l(t) \delta(\tau - \tau_l),$$

□

Where L is the number of taps, α_l is the l_{th} complex path gain, and τ_l is the corresponding path delay.

The individual paths can be correlated, and the channel can be sparse. At time t , the CFR of the CIR is given by

$$H(t, f) = \int_{-\infty}^{+\infty} h(t, \tau) e^{-j2\pi f \tau} d\tau$$

CFR can be if proper path is found

$$H[n, k] \equiv H(nT_f, k\Delta f) = \sum_{l=0}^{L-1} h[n, l] F_K^{kl}$$

Where $h[n, l] = h(nT_f, kt_s)$, and $F_K = e^{-2\pi j/k} T_f$ is the symbol length including CP, Δf is the subcarrier spacing, and $t_s = 1/D_f$ is the sample interval.

For the n_{th} OFDM symbol, can be rewritten as

$$\mathbf{H} = \mathbf{Fh}$$

\mathbf{H} is the column vector containing the channel at each subcarrier, \mathbf{F} is the unitary FFT matrix, and \mathbf{h} is the column vector containing the CIR taps.

At the receive antenna, rx, can be formulated as

$$\begin{aligned}
 y_{rx}[n, m] &= \sum_{tx=1}^{N_{tx}} \sum_{l=0}^{L-1} x_{tx}[n, m-l] h_{rxtx}^m[n, l] \\
 &+ i_{rx}[n, m] + w_{rx}[n, m],
 \end{aligned}$$

where $rx=1, \dots, N_{rx}$,

After taking FFT of the timedomain samples, the received samples in frequencydomain can be expressed as,

where $I_{rx}[n, k]$ and $W_{rx}[n, k]$ are the corresponding frequencydomain components calculated from $i_{rx}[n, m]$ and $w_{rx}[n, m]$, respectively.



for $r_{x_{th}}$ receive antenna and n_{th} OFDM symbol, we get

$$\begin{aligned}
 Y_{rx} &= \sum_{tx=1}^{N_{tx}} F \Xi_{rx,tx} F^H X_{tx} + I_{rx} + W_{rx}, \\
 &= \sum_{tx=1}^{N_{tx}} \Psi X_{tx} + I_{rx} + W_{rx}.
 \end{aligned}$$

Here, Y_{rx} is column vector storing the received signal at each subcarrier, F is the unitary FFT matrix with entries $e^{-j2\pi mk/K}$ with m and k being the row and column index. which can be considered as the equivalent channel between each received and all the transmitted subcarriers.

IV. CHANNEL ESTIMATION TECHNIQUES FOR MIMO-OFDM

MIMO-OFDM Pilot

Depending on the arrangement of pilots, three different types of pilot structures are considered: block type, comb type, and lattice type.

DFT-based channel estimation

The DFT-based channel estimation technique has been derived to improve the performance of LS or MMSE channel estimation by eliminating the effect of noise outside the maximum channel delay. Note that the maximum channel delay L must be known in advance. This technique is used for noise reduction.

Semi-blind channel estimator

Semi-blind channel estimators are another class of channel estimators that utilize not only that part of signal corresponding to the training symbols but also the part corresponding to data symbols. In particular, a semi-blind channel estimator takes $\{sp1, sp2, b\}$ to generate a channel estimate.

Blind channel estimation

Using the statistical properties of received signals, the channel can be estimated without resorting to the preamble or pilot signals. Obviously, such a blind channel estimation technique has an advantage of not incurring an overhead with training signals. However, it often needs a large number of received symbols to extract statistical properties. Furthermore, their performance is usually worse than that of other conventional channel estimation techniques that employ the training signal. It consists of a filter, zero-memory nonlinear estimator, and adaptive algorithm.

Training and estimation based channel estimation

Training symbols can be used for channel estimation, usually providing a good performance. However, their transmission efficiencies are reduced due to the required overhead of training symbols such as preamble or pilot tones that are transmitted in addition to data symbols. The least-square (LS) and minimum-mean-square-error (MMSE) techniques are widely used for channel estimation when training symbols are available.

Pilot based channel estimation

In the pilot mode, only few subcarriers are used for the initial estimation process. Depending on the stage where the estimation is performed, estimation techniques will be considered under time and frequency domains techniques. In frequency domain estimation techniques, as a first step, CFR for the known pilot subcarriers is estimated. These LS estimates are then extrapolated to get the channel at the non-pilot subcarriers. The process of the extrapolation can be denoted as

$$\hat{H} = Q \hat{H}_{LS}$$



Where Q is the interpolation/extrapolation matrix. The goal of the estimation technique is to obtain Q with lower computational complexity but at the same time is to achieve higher accuracy for a given system. In this subsection, the calculation of matrix Q for simple interpolation techniques will be discussed.

Let A is the diagonal matrix of pilots as $A = \text{diag}\{A_0, A_1, \dots, A_N\}$, N is the number of pilots in one OFDM symbol, \hat{h} is the impulse response of the pilots of one OFDM symbol, and Z is the Channel noise.

At the receiving end signal received is written as

$$B = AF\hat{h} + Z$$

where B is the vector of output signal after OFDM demodulation as $B = \{B_0, B_1, \dots, B_{N-1}\}^T$
 F is the Fourier transfer matrix as

Where weights of Fourier matrix is

$$W_N^{i,k} = \frac{1}{\sqrt{N}} e^{-j2\pi(\frac{ik}{N})}$$

The detection function is

$$\begin{aligned} K &= |B - AF\hat{h}|^2 \\ &= (B - AF\hat{h})^H (B - AF\hat{h}) \\ &= B^H B - B^H AF\hat{h} - A^H BF^H \hat{h}^H + A^H F^H \hat{h}^H AF\hat{h} \end{aligned}$$

For the minimization of K

$$\begin{aligned} \frac{\partial K}{\partial \hat{h}^H} &= 0 \\ &= -F^H A^H B + F^H A^H AF\hat{h} \\ &= 0 \end{aligned}$$

V.CONCLUSION

A review of different channel estimation techniques has been discussed. Different channel estimators such as pilot based estimator, blind channel estimator and semi-blind channel estimators have been discussed and it is concluded that pilot based channel estimation is far better than others, because blind and semi-blind channel estimator use mathematical information about the transmitted data and become complex. Block type arrangement and comb type arrangement for pilot insertion have been reviewed and compared. Block type arrangement is used for slow fading channel whereas comb type arrangement is used for fast fading channel. In block type arrangement includes algorithms like LSE, MMSE whereas comb type arrangement includes interpolation techniques such as piecewise constant interpolation, linear interpolation, second order interpolation, cubic spline interpolation and time domain interpolation techniques. It has been found that the performance of MMSE is much better than LSE but computation is very complex when number of subcarrier of OFDM increases. However, applying the DFT on the estimated output of these algorithms the results can be improved. DFT based channel estimation technique allows the reduction of noise component owing to operation in the transform domain and thus providing higher estimation accuracy.

REFERENCES

- [1]. Adnan Kiayani, Lauri Anttila, Yaning Zou, and Mikko Valkama, "Channel Estimation and Equalization in Multiuser Uplink OFDMA and SC-FDMA Systems Under Transmitter RF Impairments" *IEEE TRANSACTIONS ON VEHICULAR TECHNOLOGY*, VOL. 65, NO. 1, JANUARY 2016 pp 82-99.



- [2]. Farah Zaarour and Eric Pierre Simon “Fast Time-Varying Channel Estimation for OFDM Systems with Narrowband Interference” *IEEE WIRELESS COMMUNICATIONS LETTERS*, VOL. 4, NO. 4, AUGUST 2015 pp 389-392.
- [3]. Adam Noel, IEEE, Karen C. Cheung, and Robert Schober, , IEEE “Joint Channel Parameter Estimation via Diffusive Molecular Communication” *IEEE WIRELESS COMMUNICATIONS LETTERS*, VOL. 4, NO. 4, AUGUST 2015 pp 389-392.
- [4]. Istdeo Singh, Sheetal Kalyani, and K. Giridhar “A Practical Compressed Sensing Approach for Channel Estimation in OFDM Systems” *IEEE COMMUNICATIONS LETTERS*, VOL. 19, NO. 12, DECEMBER 2015.
- [5]. Saeed Abdallah and Ioannis N. Psaromiligkos” Semi-Blind Channel Estimation with superimpose Training for OFDM-Based AF Two-Way Relaying” *IEEE TRANSACTIONS ON WIRELESS COMMUNICATIONS*, VOL. 13, NO. 5, MAY 2014 pp 2468-2477.
- [6]. Meili, Xiang Wang, Kun Zhang “Comparative Study of Adaptive Filter Channel Estimation Technique in MIMO-OFDM System Based on STBC” *Proceedings of the 2014 International Conference on Machine Learning and Cybernetics, Lanzhou*, 13-16 July, 2014
- [7]. Andre Antonio dos Anjos, Andre Antonio dos Anjos, Andre Antonio dos Anjos “Channel Estimation on MIMO-OFDM System” *IEEE WIRELESS COMMUNICATIONS LETTERS*, VOL. 15, NO. 4, DEC 2013 .
- [8]. S. Abdallah and I. N. Psaromiligkos, “Blind channel estimation for amplify-and-forward two-way relay networks employing M-PSK modulation,” *IEEE Trans. Signal Process.* vol. 60, no. 7, pp. 3604–3615, Jul. 2012.
- [9]. S. Abdallah and I. N. Psaromiligkos, “Exact Cramer-Rao bounds for semi-blind channel estimation in amplify-and-forward two-way relay networks employing square QAM modulation,” ArXiv pre-print cs.IT/1207.5483, Jul. 2012.
- [10]. S. Zhang, F. Gao, and C. Pei, “Optimal training design for individual channel estimation in two-way relay networks,” *IEEE Trans. Signal Process.*, vol. 60, no. 9, pp. 4987–4991, Sep. 2012.
- [11]. G. Wang, F. Gao, W. Chen, and C. Tellambura, “Channel estimation and training design for two-way relay networks in time-selective fading environments,” *IEEE Trans. Wireless Communication.*, vol. 10, no. 8, pp. 2681–2691, Aug. 2011.
- [12]. Zhang Jie, Huang Liqun, “An Improved DFT-based Channel Estimation Algorithm for MIMO-OFDM Systems”, *IEEE*, vol.2, pp.3929-3932, 201