



# **Voice Integrated Speed and Direction Control For DC Motor**

**Ajai.T.Kochupurackal<sup>1</sup>, Abin.Shaju<sup>2</sup>, Ajil.Aleyas<sup>3</sup>, Aswathy.Mohanan<sup>4</sup>, Basil.Kumar.N.K<sup>5</sup>**

UG students, Dept. of EEE, Mar Baselios Institute of Technology and Science, Nellimattom, Kerala, India<sup>1234</sup>

Assistant Professor, Dept. of EEE, Mar Baselios Institute of Technology and Science, Nellimattom, Kerala, India<sup>5</sup>

**ABSTRACT:** It is very difficult to work in hazardous environment in many of the industries. Human can survive only certain amount of humidity, temperature, pressure, etc. Working in environments like this will cause threat to human life, so precautions should be taken against this. To overcome this huge loss voice control was developed. Due to the advancement of wireless technology, there are several connections are introduced such as GSM, Wi-Fi and Bluetooth. Each of the connection has their own unique specifications and applications. The speed control was implemented using Bluetooth technology to provide communication access from smart phone. Communication plays a major role in day today's life and can be used as a better tool in control system. It deals with wireless communication and voice recognition and is used to control the motor speed. There are numerous techniques for speed control. Using voice as input control will reduce the manual operation. Voice recognition applications can be interfaced and speed control of DC motors can be done using the Arduino UNO microcontroller or Raspberry Pi. In addition to this IR sensor is used to sense the motor speed and in turn speed of the motor can be received via Bluetooth to the android mobile. If we control the Industrial Devices system using Speech then we can save enough time to do other sophisticated work. The voice control is highly reliable and fast. Thus the IOT makes the industrial automation much more easier.

**KEYWORDS:** Arduino UNO, Bluetooth, IR Speed sensor, Android phone, DC Motor.

## **I.INTRODUCTION**

Due to the huge advancements in technologies, the industries are automated. There were huge loss of life in industries each year. After the boom of technology this loss is reduced to considerable amount. To create an alternative to work in hazardous environment voice control was developed. Communication through wireless technology was limited to the field of communication. So we integrate the mobile technology advancements with the embedded system to develop our speed control drive. Through mobile one could communicate with the hardware in parts of the world by sending voice control through mobile. The android phone observes the specific voice of the person and that voice is tuned by means of recognition, which results in accurate transcription. Voice control is used mainly to reduce the manual operation. Voice communication can be used to control various fields. PMW technique can be used to control the speed of DC motor. In this, voice is going to be used as input. Engineers always search for easy way to control motor functions. Speed control of DC motor is used for various applications. Controlling the DC motor using voice was a tedious process.

In the system designed android phone is used for voice recognition. For this purpose special android applications are introduced. The voice input given to phone is converted to text and sends to the Arduino board using bluetooth. For this purpose bluetooth module is interfaced with the arduino. The text received at arduino is decoded. The program is executed and the control signal is given to the motor driver circuit. The driver circuit controls the speed and direction of the DC motor.

# International Journal of Advanced Research in Electrical, Electronics and Instrumentation Engineering

(An ISO 3297: 2007 Certified Organization)

Website: [www.ijareeie.com](http://www.ijareeie.com)

Vol. 6, Issue 3, March 2017

## II. SYSTEM BASIC BLOCK DIAGRAM AND WORKING

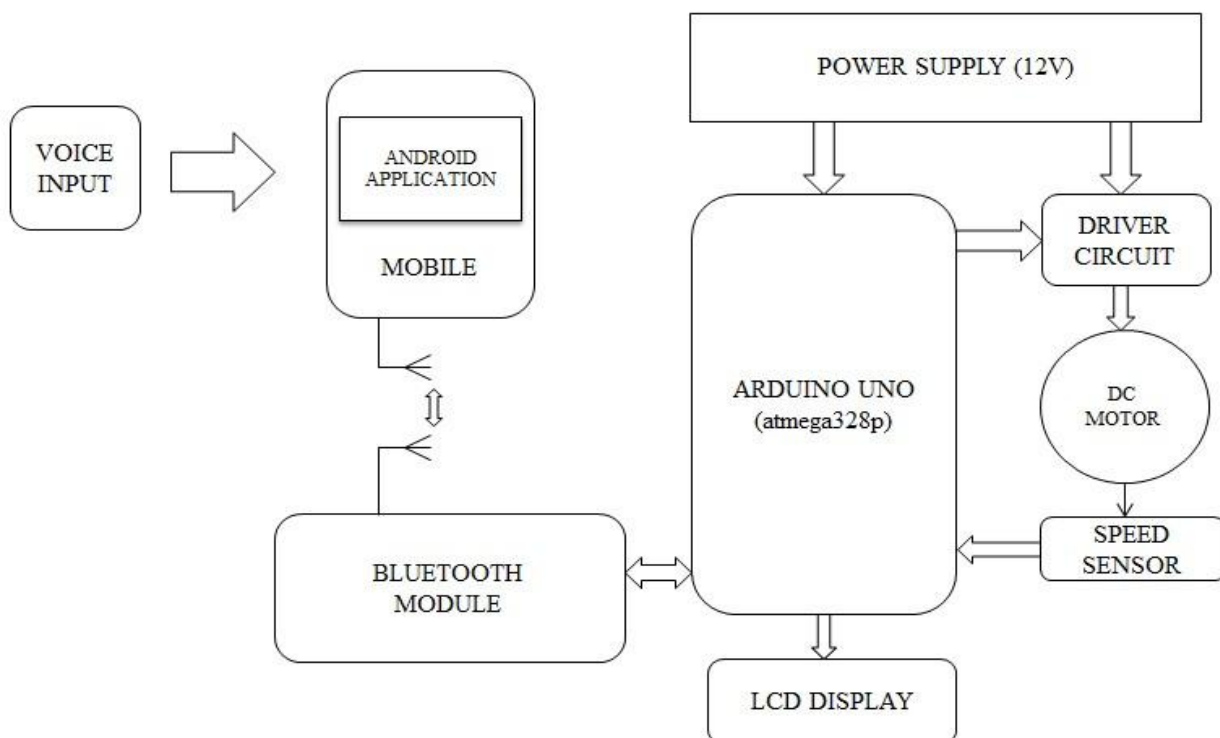

Fig.1: Basic Block Diagram

The proposed system's block diagram is shown above. Voice input is given to the android mobile phone. The mobile uses an android application for voice recognition. The application has the feature of sending voice commands from the mobile phone to the robot to which the phone is connected. Voice command is given to mobile phone. The converts the voice into text, which is then send to the arduino board. The voice is send to the Bluetooth module interfaced with Arduino UNO. HC-05 is the Bluetooth module used with arduino. Voice command is converted into radio signal with frequency 2.4 GHz and transmitted to the Arduino UNO. It converts the given text input signal to pulsating signal by pulse width modulation (PWM) using Arduino programming. The Arduino is programmed using ARDUINO IDE software. The pulse width modulated signal is converted into the driving signal. This is done by motor driver L298. The motor driver can run two motors simultaneously given output from 5V-35V.

When the phone is connected to the Arduino board, give the voice input "start". Then the system is ready to operate. Now give the direction in which the motor is to be rotated. The two direction commands used are "clockwise" and "anticlockwise". After that provide voice input to phone by giving the speed at which the motor is rotated. Then the motor starts rotating in the specified direction and speed. The speed is sensed by the IR speed sensor. The speed sensor is directly connected to the Arduino UNO board. It has got an IR transmitter and receiver. The speed of the motor is measured continuously for enabling a closed loop operation, so that the reliability of the system increases. The speed sensed and the commands that reach the arduino are displayed using a LCD display.



# International Journal of Advanced Research in Electrical, Electronics and Instrumentation Engineering

(An ISO 3297: 2007 Certified Organization)

Website: [www.ijareeie.com](http://www.ijareeie.com)

Vol. 6, Issue 3, March 2017

## III. HARDWARE COMPONENTS

### A. ARDUINO UNO

The Arduino Uno is a microcontroller board based on the ATmega328P. It has 14 digital input/output pins (of which 6 can be used as PWM outputs), 6 analog inputs, a 16 MHz crystal oscillator, a USB connection, a power jack, an ICSP header, and a reset button. It contains everything needed to support the microcontroller; simply connect it to a computer with a USB cable or power it with a AC-to-DC adapter or battery to get started. The Uno differs from all preceding boards in that it does not use the FTDI USB-to-serial driver chip. Instead, it features the Atmega8U2 programmed as a USB-to-serial converter. "Uno" means one in Italian and is named to mark the upcoming release of Arduino 1.0. Clock speed of Arduino UNO is 16MHz. The Arduino/Genuino Uno board can be powered via the USB connection or with an external power supply. The power source is selected automatically. The board can operate on an external supply from 6 to 20 volts. If supplied with less than 7V, however, the 5V pin may supply less than five volts and the board may become unstable. If using more than 12V, the voltage regulator may overheat and damage the board. The recommended range is 7 to 12 volts.

### B. BLUETOOTH MODULE (HC-05)

HC-05 module is an easy to use Bluetooth SPP (Serial Port Protocol) module, designed for transparent wireless serial connection setup. The HC-05 Bluetooth Module can be used in a Master or Slave configuration, making it a great solution for wireless communication. This serial port bluetooth module is fully qualified Bluetooth V2.0+EDR (Enhanced Data Rate) 3Mbps Modulation with complete 2.4GHz radio transceiver and baseband. It uses CSR Bluecore 04-External single chip Bluetooth system with CMOS technology and with AFH (Adaptive Frequency Hopping Feature). The Bluetooth module HC-05 is a MASTER/SLAVE module. By default the factory setting is SLAVE. The Role of the module (Master or Slave) can be configured only by AT COMMANDS. The slave modules cannot initiate a connection to another Bluetooth device, but can accept connections. Master module can initiate a connection to other devices. The user can use it simply for a serial port replacement to establish connection between MCU and GPS, PC to embedded system.

### C. LCD DISPLAY

LCD (Liquid Crystal Display) screen is an electronic display module and used in wide range of applications. A 16x2 LCD display is very basic module and is very commonly used in various devices and circuits. These modules are preferred over seven segments and other multi segment LEDs. The reason is that LCDs are economical, easily programmable, have no limitation of displaying special and even custom characters, animations and so on. A 16x2 LCD means it can display 16 characters per line and there are 2 such lines. In this LCD each character is displayed in 5x7 pixel matrix. This LCD has two registers namely, Command and Data. The command register stores the command instructions given to the LCD. The data register stores the data to be displayed on the LCD. The data is the ASCII value of the character to be displayed on the screen.

### D. MOTOR DRIVER (L298)

The L298N is an integrated monolithic circuit in a 15-lead Multiwatt and PowerSO20 packages. It is a high voltage, high current dual full-bridge driver designed to accept standard TTL logic level and drive inductive loads such as relays, solenoids, DC and stepping motors. The driver has high operating voltage, which can be up to 40 volts. L298 have a high-capacity filter capacitor and a freewheeling diode that protects devices in the circuit from being damaged by the reverse current of an inductive load, enhancing reliability of the driver. The module can be applied to Drive DC motors. Since the module uses a dual H-bridge drive, it can drive two motors at the same time.



# International Journal of Advanced Research in Electrical, Electronics and Instrumentation Engineering

(An ISO 3297: 2007 Certified Organization)

Website: [www.ijareeie.com](http://www.ijareeie.com)

Vol. 6, Issue 3, March 2017

## E. IR SPEED SENSOR

The motor speed is sensed using an IR speed sensor. Here we use speed sensor based on the LM393 chip. The speed sensor uses a disc with holes (encoder disc) to block the infrared beam, thus by counting the number of times the sensors goes from low to high we can calculate the number of revolutions for a given time period. There are two infrared LEDs present in the speed sensor. One LED is IR transmitter and the other one is IR receiver (phototransistor). If no object blocks, the phototransistor would conduct; when something blocked the light falling on the transistor it wouldn't conduct. When there is no object between the interrupter will be logical "0". During the rotation, the object will block light output from optocoupler will be a logical "1". IR speed sensors are cheaper and accurate.

## IV. SOFTWARE USED

### A. PROTEUS

Proteus Design suite is an Electronic Design Automation (EDA) tool including schematic capture, simulation and PCB designing and layout modules. The software runs on windows operating system and is available in English and other many languages. The microcontroller simulation in proteus works by applying either a hex file or a debug file to the microcontroller part on the schematic. It is then connected to it. This enables its usage in a board spectrum of project prototyping in areas such as motor control, temperature control and user interface design. It also finds use in general applications and since no hardware is required. It is convenient to use as training or teaching tool. There are many advantages for proteus, which includes powerful string manipulation, comprehensibility of proteus scripts and availability of advanced data structures. The language can be extended by adding user functions written in proteus or DLLs created in C/C++.

### 1. MODELLING

Modelling of designed system is done in proteus 8.1. The system model is made as easy, so that everyone understood the model. Here 2 logic inputs are used for system simulation.

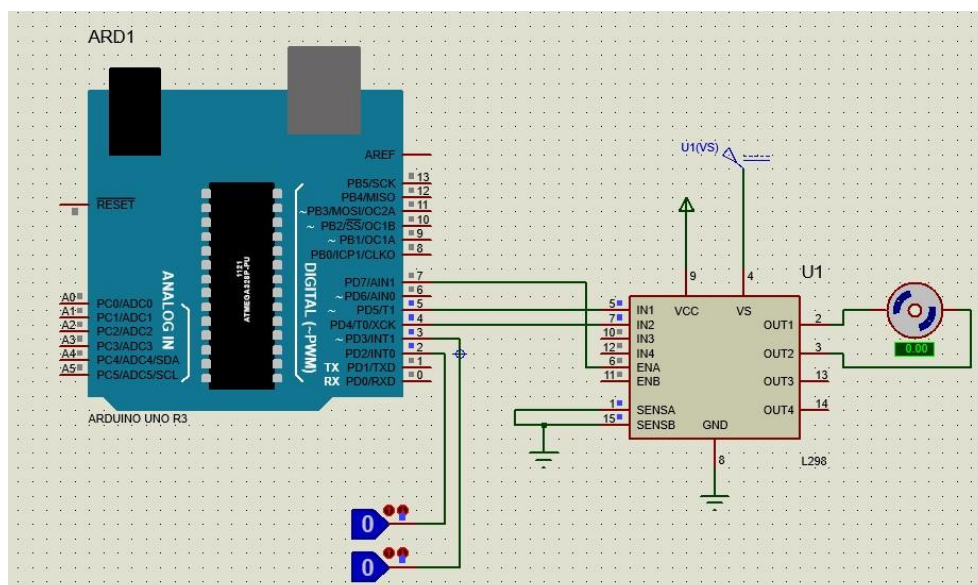

# International Journal of Advanced Research in Electrical, Electronics and Instrumentation Engineering

(An ISO 3297: 2007 Certified Organization)

Website: [www.ijareeie.com](http://www.ijareeie.com)

Vol. 6, Issue 3, March 2017

## 2. SIMULATION OUTPUT

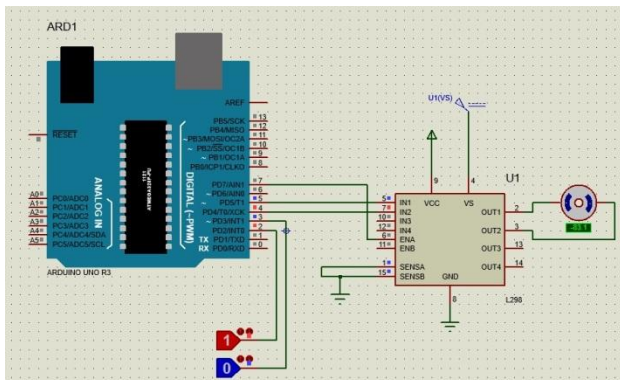

Fig.2

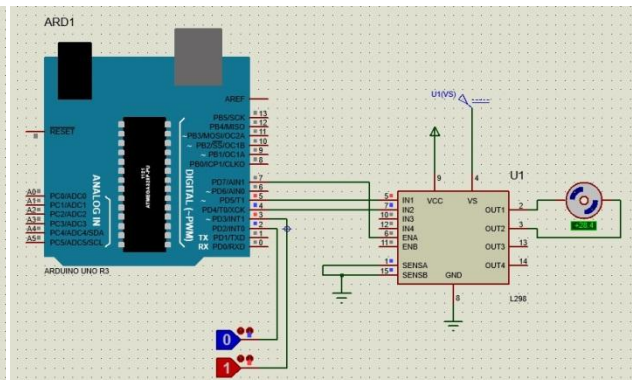

fig.3

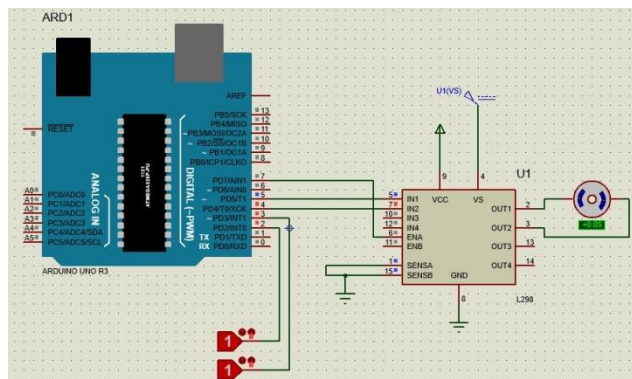

Fig.4

The three states of simulations are shown above. In the fig.2, logic input 1 is made 'one', then the motor rotates in the anticlockwise direction and it is indicated by negative speed. In the fig.3, the logic input 2 is made 'one' and the input 1 as 'zero', then the motor rotates in the clockwise direction indicated by positive speed. In the fig.4, both the logic inputs are made '1', then the motor stops.

### B. ARDUINO IDE

Arduino is an open-source platform used for building electronics projects. Arduino consists of both a physical programmable circuit board and a piece of software, or IDE (Integrated Development Environment) that runs on your computer, used to write and upload computer code to the physical board. Unlike most previous programmable circuit boards, the Arduino does not need a separate piece of hardware in order to load new code onto the board – you can simply use a USB cable. Additionally, the Arduino IDE uses a simplified version of C++, making it easier to learn to program.



# International Journal of Advanced Research in Electrical, Electronics and Instrumentation Engineering

(An ISO 3297: 2007 Certified Organization)

Website: [www.ijareeie.com](http://www.ijareeie.com)

Vol. 6, Issue 3, March 2017

## C. ANDROID APPLICATION

Control your Arduino with voice commands using an Android smartphone. The App works by pressing the microphone button, then it will wait for you to say a command. The app will then display the word's that you've stated and will send data strings to the Arduino and arduino generates the PWM control signal for the motor driver and the speed and direction of the DC motor is controlled.

## V. CONCLUSION

The proposed system is a wireless system with bluetooth connectivity and is fast, so it saves the time and can be used in hazardous environments where humans cannot survive. With the speed feedback mechanism, the system is much more reliable than any other open loop control mechanism. In this project android mobile phone acts as a microphone and the voice command is given to the mobile and speed is varied, and thus the system provides a new technology for industrial and home automation.

## REFERENCES

- [1] T.Mathurri Sail, S.Keerthi Kumar, "Speed Control Of Dc Motor Using Voice Commands" International Conference on Computation of Power, Energy Information and Communication (ICCPEIC), 2016.
- [2] B.Gokul, K.Karthi, A.Thiyagaseelan, V.Santhosh K, "Android Based Closed Loop Speed Control of Dc Motor Using Voice Recognition via Bluetooth", International Journal of Advanced Research in Electrical, Electronics and Instrumentation Engineering(IJAREEIE), March 2016.
- [3] Lin Zhong, Yanxiong Li, XinWei, Guanglong Li, Zili Wang, YewenJiang, "System Design For Monitoring Infant Speech Emotion", IEEE International Conference On Control And Automation (IccA)Hangzhou, China, June 12-14, 2013.
- [4] N.H. Ismail, and E.I.Saadon, "Android-Based Home Door Locks Application via Bluetooth for Disabled People", Proceedings of the International Conference on control System, Computing and Engineering, Penang, IEEE, 28-30 November 2014.
- [5] Prabhu. S et.al, "Voice enabled speed control of ac motor", International Journal of Research in Engineering and Technology(IJRET), 2014.
- [6] Mohammed Asgar et.al, "Automated Innovative Wheelchair", International Journal of Information Technology Convergence and Services(IJITCS), 2015.
- [7] M.R. Manikandan et.al, "Device Control Using Voice Recognition in Wireless Smart Home System", International Journal of Innovative Research in Computer and Communication Engineering(IJIRCCCE), 2015.
- [8] R. Puviasriet.al , " Low Cost Self-assistive Voice Controlled Technology for Disabled People", International Journal of Modern Engineering Research,2013.
- [9] MohdFakhizan bin Romlie, Mohammad FadhilPesol, and KhairulNisakMdHasan, "PWM Technique to Control Speed of Induction Motor usingMatlab/xPC Target Box," in Proc. PECOn 2008 Power and Energy Conference.
- [10] D. K. Prabitha, Chidananda Murthy. M. V & M. Z. Kurian "Speech Recognizing Powered Wheelchair for Disabled" International Conference on Electrical Engineering and Computer Science. May 12th, 2012, Trivendum, ISBN Number : 978-93-81693-58-2.