



ISSN (Print) : 2320 – 3765
ISSN (Online): 2278 – 8875

International Journal of Advanced Research in Electrical, Electronics and Instrumentation Engineering

(An ISO 3297: 2007 Certified Organization)

Vol. 5, Issue 6, June 2016

A Study on TSCS, SSSC, SVC Facts Device

Suraj Kumar, Priyajit Dash

M.Tech Student, Department of EEE, BRCM College of Engineering, Behal, Bhiwani Haryana, India

Asst. Professor, Department of EEE, BRCM College of Engineering, Behal, Bhiwani Haryana, India

ABSTRACT: Since the emergence of power electronic devices, FACTS devices have taken complete hold on the market of power system, today we cant imagine the power industry without these devices. Flexible Alternating Current Transmission Systems(FACTS) incorporating power electronic-based and other static controllers to enhance controllability and increase power transfer capability. This is a basic study paper which I was writing with my knowledge regards FACTS devices and I am going to utilize these devices in designing of a power system that comprises of three machine with nine buses. In my next paper I will use these devices to make some simulink models on MATLAB and will analyze the stability of Power System. On the study of TSCS, SSSC, SVC we will draw some conclusion regards their application and quality in terms of stabilize operation and complexity, which will be decisive in our practical model.

KEYWORDS: SVC, FACTS, TSCS, SSSC, VAR, Controller.

I. INTRODUCTION

The FACTS is generic term representing the application of power electronics based solutions to AC power system. With the development and application of power electronics technology and maturity of manufacturing, more and more power semi-conductor based devices, called FACTS [2], with ratings from tens to hundreds of Giga watts, have been utilized in the power systems to satisfy the function of achieving better power transferability and enhancing power system controllability. FACTS actually is the application of power electronic equipment, with one or multiple functions, to regulate and control the electrical parameters that govern the operation of transmission systems including voltage, current, impedance, phase angle and damping of oscillations [2]. FACTS controllers can cause rapid changes of the important system parameters mentioned above. Their presence, therefore, can significantly affect the operation of traditional distance schemes when either series or shunt connected FACTS devices introduce new dynamic controls into the power systems. They would inevitably affect the characteristics of a protective relay in a transmission line to some extent. There are several advantages of FACTS devices, which are described below.

Advantage of FACTS Devices

- a) Control of power flow as ordered. The use of control of the power flow may be to follow a contract, meet the utilities own needs, ensure optimum power flow, ride through emergency conditions, or a combination thereof.
- b) Increasing the loading capability of lines to their thermal capabilities, including short term and seasonal.
- c) Increasing the system security through raising the transient stability limit, limiting short circuit currents and overloads, managing cascading black outs and damping electromechanical oscillations of power systems and machines.
- d) Providing secure tie line connections to neighboring utilities and regions thereby decreasing overall generation reserve requirements on both sides.
- e) Providing greater flexibility in setting new generation.
- f) Increasing utilization of lowest cost generation. Because the voltage, current, impedance, real power, and reactive power are interrelated, each controller has multiple attributes of what they can do in terms of controlling the voltage, power flow, stability and so on.
- g) Power Quality Improvement.
- h) Flicker Mitigation.
- i) Interconnection of renewable and distributed generation and storages.



International Journal of Advanced Research in Electrical, Electronics and Instrumentation Engineering

(An ISO 3297: 2007 Certified Organization)

Vol. 5, Issue 6, June 2016

j) Increase in transmission efficiency.

These systems can provide compensation in both series or shunt or a combination of both series and shunt. The FACTS can attempt the compensation by modifying impedance, voltage and phase angle.

This paper will be organized in manner that it will be able to describe the behavior of FACT devices like SSSC, TCSC, SVC. In the second part we will describe the different method can be utilized for the compensation of FACT device. In the third part we will describe principle and characteristic of series FACT controller. Fourth part will comprise about this. At the end of this paper we will draw an conclusion which will be helpful in my thesis work.

II. COMPENSATION

AC system mainly consists of inductive load so it requires reactive power for its operation and hence, the source must supply it, increasing the current from the generator and through power lines. If reactive power is supplied near the load, the line current can be reduced or minimized resulting into lower losses and improving voltage regulation at the load terminals.

A. Series Compensation

The conventional Series compensators employ switches to add inductive or capacitive reactance in transmission line. The conventional compensator emulates a static flow controller by means of mechanical switching.

Series compensation can also be implemented by injecting a voltage source in series with transmission line as shown in fig 1. The voltage source can inject voltage of controllable magnitude and phase. When the injected voltage is in phase Quadrature leading to line current, series compensation emulates like an inductor, similarly when injected voltage lagging to line current it emulates a capacitor. The result obtained with series compensation through a voltage source, which has been adjusted again to have unity power factor operation at voltage V_2 . In this case, voltage VCOMP has been added between the line and the load to change the angle of V_2 , which is now the voltage at load side. VCOMP generates a voltage with opposite direction to the voltage drop in line inductance because it lags line current I_p .

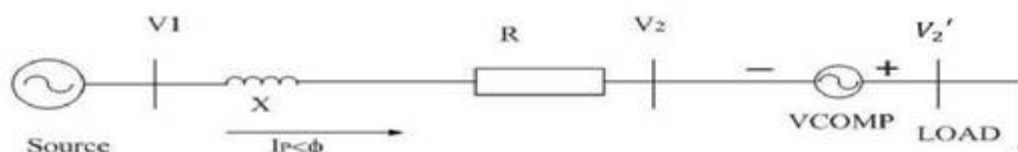

Figure 1 Representation of AC system with series compensation

B. Shunt Compensation

Shunt compensation is used to influence the natural electrical characteristics of the transmission line to increase the steady-state transmittable power and to control the voltage profile along the line. The shunt compensator like STATCOM can be operated either to provide capacitive or inductive compensation depending on the specific requirement. The impedance of the shunt controller, which is connected to the line voltage, causes a variable current flow, and hence represents an injection of current into the line. As long as the injected current is in phase Quadrature with the line voltage, the shunt controller only supplies or consumes variable reactive power.

The shunt capacitive compensator is used to improve the power factor; most of the practical loads are inductive and results into lagging power factor. To compensate, a shunt capacitor is connected which draws current leading the source voltage. The net result is improvement in power factor.

The shunt inductive compensator is used either when charging the transmission line, or, when there is very low load at the receiving end. Due to very low or no load a very low current flows through the transmission line. Shunt capacitance in the transmission line causes voltage amplification (Ferranti effect). At no load the receiving end voltage may increase abnormally high in very long transmission lines. To compensate, shunt inductors are connected across the transmission line. In Fig. 2, a current source device is being used to compensate the reactive component of the load current (I_Q).

International Journal of Advanced Research in Electrical, Electronics and Instrumentation Engineering

(An ISO 3297: 2007 Certified Organization)

Vol. 5, Issue 6, June 2016

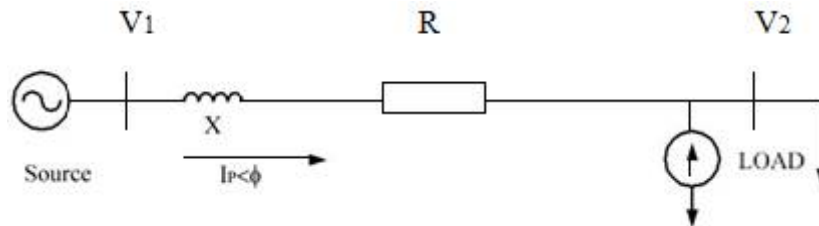

Figure 2 Representation of AC system with Shunt compensation

III. SERIES CONTROLLERS

A. Static Synchronous Series Compensator

The static synchronous series compensator is based on the voltage source converter (VSC). The basic structure of SSSC is shown in fig. below. As the name suggesting it is connected in the series in the transmission line via a transformer. The SSSC injects a balanced set of voltage at the fundamental frequency that lags or lead behind the line current by 90 degree. This means that SSSC can be controlled to provide a series capacitive or inductive compensation. SSSC has no prohibited region so the series compensation can be changed from inductive to capacitive and vice versa. If the SSSC is provided with a storage source then it can exchange real power with the power system. With a proper control arrangement the SSSC can also be used to control the flow of power. As the reactive compensator the SSSC has two magnitude nodes a).the constant reactance mode and b).the constant Quadrature voltage mode .In the former the SSSC voltage is function of line current while in the later the SSSC voltage is independent of line current .

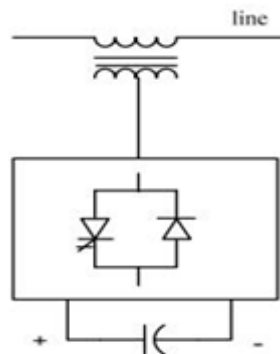

Figure 3 Schematic diagram of SSSC

Principle Operation of SSSC

Static synchronous series compensator (SSSC) when coupled to an energy storage capacitor an SSSC can only absorb or generate reactive power to and from the system. The SSSC is operated as series compensator without an external energy source whose output voltage is controlled and is in Quadrature with the line. The variable reactance influence the electric power flow in the transmission line. A small component of the voltage which is in phase with the line current provides for the losses in the inverter.

International Journal of Advanced Research in Electrical, Electronics and Instrumentation Engineering

(An ISO 3297: 2007 Certified Organization)

Vol. 5, Issue 6, June 2016

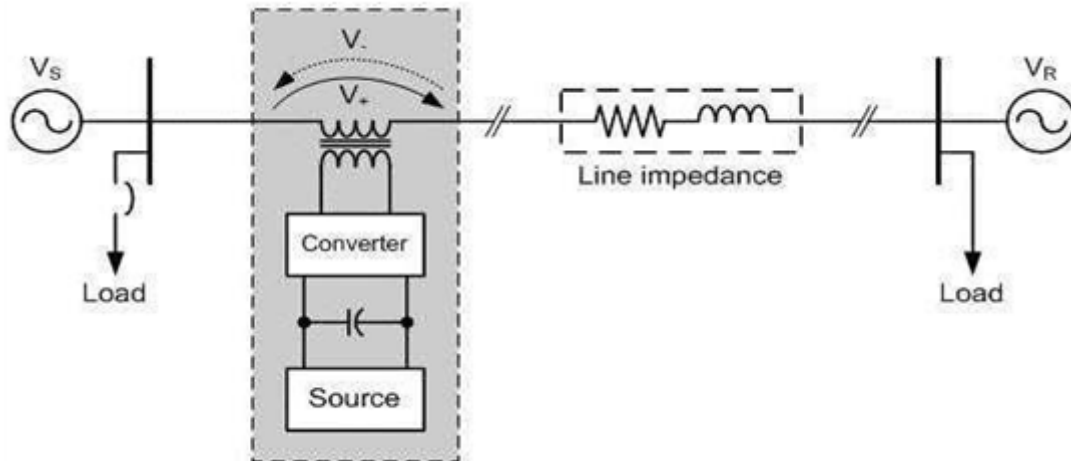

Fig 4 Basic two machine system with SSSC

1. Voltage source converter(VSC)-main component
2. Transformer-Couples the SSSC with transmission line.
3. Energy source-provides the voltage across DC capacitor and compensate the device losses.

The compensating reactance X_q is defined to be negative when SSSC is operated in inductive mode and when the compensating reactance is positive then the SSSC is operating in capacitive mode. This compensating reactance effect the normalized power flow in transmission line. When the emulated reactance is inductive the real and reactive power flow decrease and the effective reactance increases as the reactive increases in the negative direction and when the emulated reactance is capacitive the real and reactive power increase and the effective reactance decrease as the reactive compensation increase in positive direction. The magnitude of inserted voltage is fully controlled while the phase angle is maintained in quadrature with the line current.

Modes of Operation of SSSC

1. Normal mode of operation
2. Inductive mode of operation
3. Capacitive mode of operation

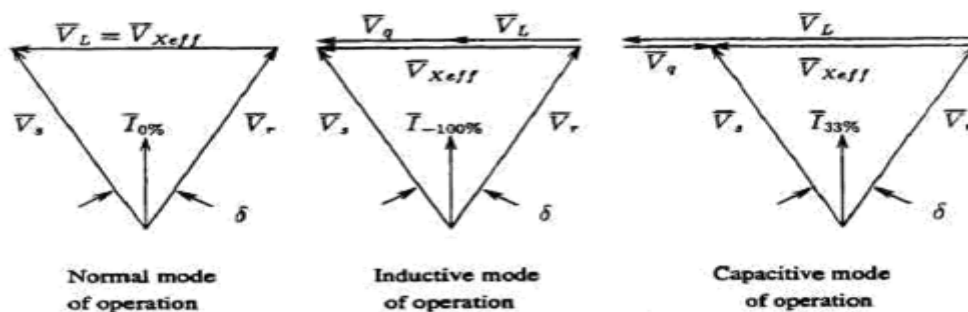

Fig 4 Different modes of SSSC.

B. Thyristor Controlled Series Compensator

It consists of a series capacitor bank shunted by a thyristor-controlled reactor in order to provide a smoothly variable series capacitive reactance as shown in Fig 5, the bi-directional thyristor valve that is fired with an angle α ranging

International Journal of Advanced Research in Electrical, Electronics and Instrumentation Engineering

(An ISO 3297: 2007 Certified Organization)

Vol. 5, Issue 6, June 2016

between 90° and 180° with respect to the capacitor voltage.

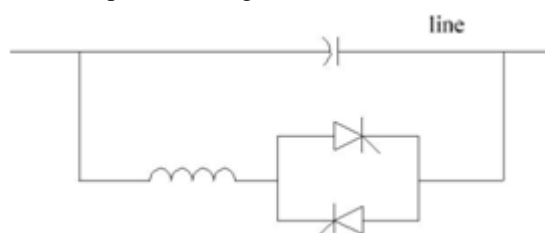

Figure 5 Schematic diagram of TCSC

The TCSC can be operated in bypass–thyristor mode, blocked-thyristor mode and vernier mode.

In bypass-thyristor mode, the thyristors are made to fully conduct with a conduction angle of 180°. Gate pulses are applied as soon as the voltage across the thyristors reaches zero and becomes positive, resulting in a continuous flow of current through the thyristor valves. The TCSC module behaves like a parallel capacitor-inductor combination.

In blocked-thyristor mode, the firing pulses to the thyristor valves are blocked. If the thyristors are conducting and a blocking command is given, the thyristors turn off as soon as the current through them reaches a zero crossing. The net TCSC reactance is capacitive.

The vernier mode allows the TCSC to behave either as a continuously controllable capacitive reactance or as a continuously controllable inductive reactance. It is achieved by varying the thyristor-pair firing angle in an appropriate range.

Basic Principle of TCSC

A TCSC provides continuous control of power on the ac line over a wide range. The principle of variable-series compensation is simply to increase the fundamental-frequency voltage across the fixed capacitor. (FC) in a series compensated line through appropriate variation of the firing angle, α . This enhanced voltage changes the effective value of the series-capacitive reactance.

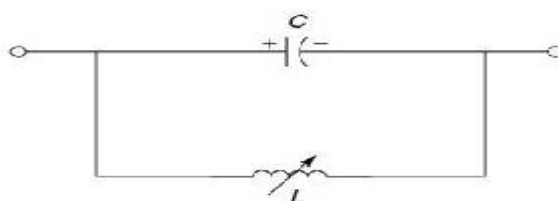

Fig 6 A variable Inductor connected in Shunt with an FC

A simple understanding of TCSC functioning can be obtained by analyzing the behaviour of a variable inductor connected in parallel with an FC, as shown in Fig 6. The equivalent impedance, Z_{eq} of this LC combination is expressed as

$$Z_{eq} = [(j1/wC)/1/jwL]$$

1. If $Z_{eq} > 0$ then the reactance is FC is less than that of parallel connected variable reactor and this combination provides a variable capacitive reactance.
2. If $Z_{eq} < 0$ then the reactance of FC is higher than that of parallel connected variable reactor and this combination provides a inductive mode of TCSC.
3. If $Z_{eq} = 0$ then a resonance develops that results in infinite capacitive impedance obviously an undesirable condition.

Impedance Characteristic curve

International Journal of Advanced Research in Electrical, Electronics and Instrumentation Engineering

(An ISO 3297: 2007 Certified Organization)

Vol. 5, Issue 6, June 2016

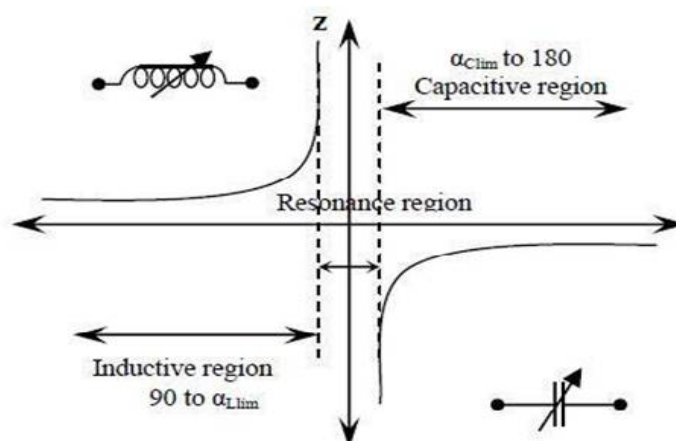

Fig 7 Impedance Vs Firing Angle characteristics curve

Net reactance of TCR, $X_L(\alpha)$ is varied from its minimum value X_L to maximum value infinity. Likewise effective reactance of TCSC starts increasing from TCR X_L value to till occurrence of parallel resonance condition $X_L(\alpha) = X_C$, theoretically XTCS is infinity. This region is inductive region. Further increasing of $X_L(\alpha)$ gives capacitive region, Starts decreasing from infinity point to minimum value of capacitive reactance X_C . Thus, impedance characteristics of TCSC shows, both capacitive and inductive region are possible though varying firing angle (α).
From

While selecting inductance, X_L should be sufficiently smaller than that of the capacitor X_C . Suppose if X_C is smaller than the X_L , then only capacitive region is possible in impedance characteristics. In any shunt network, the effective value of reactance follows the lesser reactance present in the branch. So only one capacitive reactance region will appear. Also X_L should not be equal to X_C value; or else a resonance develops that result in infinite impedance – an unacceptable condition. Note that while varying $X_L(\alpha)$, a condition should not allow to occur $X_L(\alpha) = X_C$.

IV. SHUNT CONTROLLERS

Static Var Compensator

SVC is a shunt-connected static var generator or absorber whose output is adjusted to exchange capacitive or inductive current so as to maintain or control specific parameters of the electrical power system.

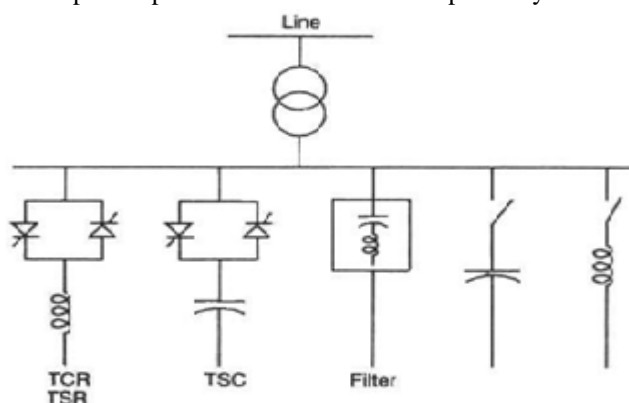

Fig 8 Schematic diagram of a line with Static VAR Compensator (SVC)

International Journal of Advanced Research in Electrical, Electronics and Instrumentation Engineering

(An ISO 3297: 2007 Certified Organization)

Vol. 5, Issue 6, June 2016

A static var compensator (or SVC) is an electrical device for providing fast-acting reactive power on high-voltage electricity transmission networks. SVCs are part of the Flexible AC transmission system device family, regulating voltage and stabilizing the system. Unlike a synchronous condenser which is a rotating electrical machine, a "static" VAR compensator has no significant moving parts (other than internal switchgear). Prior to the invention of the SVC, power factor compensation was the preserve of large rotating machines such as synchronous condensers or switched capacitor banks.

In transmission applications, the SVC is used to regulate the grid voltage. If the power system's reactive load is capacitive (leading), the SVC will use thyristor controlled reactors to consume vars from the system, lowering the system voltage. Under inductive (lagging) conditions, the capacitor banks are automatically switched in, thus providing a higher system voltage. By connecting the thyristor-controlled reactor, which is continuously variable, along with a capacitor bank step, the net result is continuously-variable leading or lagging power. In industrial applications, SVCs are typically placed near high and rapidly varying loads, such as arc furnaces, where they can smooth flicker voltage.

Operation of SVC

The Static Var Compensator (SVC) is composed of the capacitor banks/filter banks and air core reactors connected in parallel. The air-core reactors are series connected to thyristors. The current of air-core reactors can be controlled by adjusting the firing angle of thyristors. The SVC can be considered as a dynamic reactive power source. It can supply capacitive reactive power to the grid or consume the spare inductive reactive power from the grid. Normally, the system can receive the reactive power from a capacitor bank, and the spare part can be consumed by an air-core shunt reactor. As mentioned, the current in the air-core reactor is controlled by a thyristor valve. The valve controls the fundamental current by changing the firing angle, ensuring the voltage can be limited to an acceptable range at the injected node (for power system var compensation), or the sum of reactive power at the injected node is zero which means the power factor is equal to 1 (for load var compensation).

Current harmonics are inevitable during the operation of thyristor controlled rectifiers, thus it is essential to have filters in a SVC system to eliminate the harmonics. The filter banks can not only absorb the risk harmonics, but also produce the capacitive reactive power. The SVC uses close loop control system to regulate bus bar voltage, reactive power exchange, power factor and three phase voltage balance.

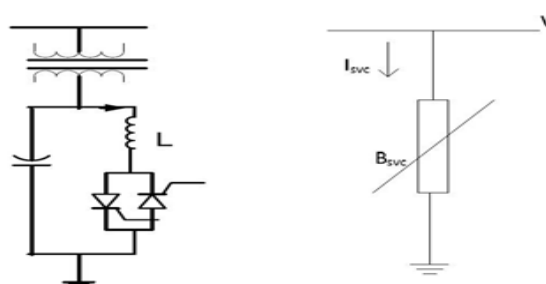

Fig. 9 Static var compensator and its equivalent circuit

Characteristic of SVC

The steady-state and dynamic characteristics of SVCs describe the variation of SVC bus voltage with SVC current or reactive power. Two alternative representations of these characteristics are shown in Fig. 10: part (a) illustrates the terminal voltage–SVC current characteristic and part (b) depicts the terminal voltage–SVC reactive-power relationship. The dynamic $V-I$ characteristics of SVCs are described.

International Journal of Advanced Research in Electrical, Electronics and Instrumentation Engineering

(An ISO 3297: 2007 Certified Organization)

Vol. 5, Issue 6, June 2016

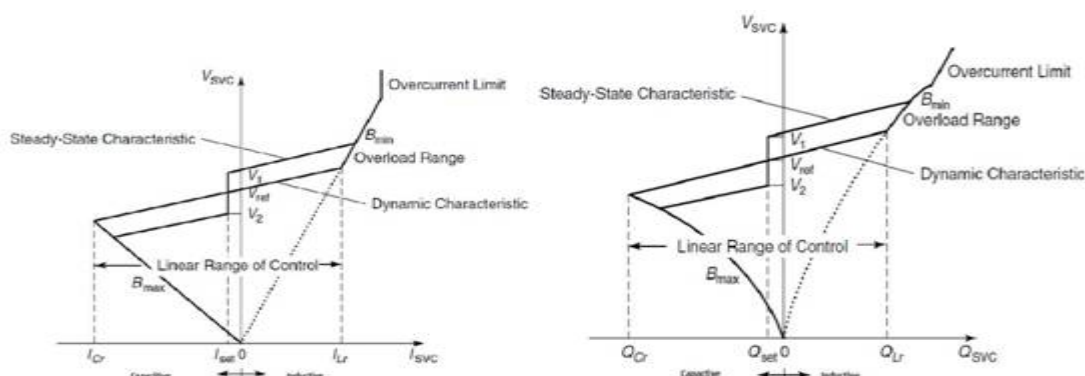

Figure 10(a) The voltage–current characteristic of the SVC and (b) the voltage– reactive-power characteristic of the SVC.

Dynamic Characteristic

Reference Voltage, V_{ref} This is the voltage at the terminals of the SVC during the floating condition, that is, when the SVC is neither absorbing nor generating any reactive power. The reference voltage can be varied between the maximum and minimum limits— $V_{ref\ max}$ and $V_{ref\ min}$ either by the SVC control system, in case of thyristor-controlled compensators, or by the taps of the coupling transformer, in the case of saturated reactor compensators. Typical values of $V_{ref\ max}$ and $V_{ref\ min}$ are 1.05 pu and 0.95 pu, respectively.

Linear Range of SVC Control This is the control range over which SVC terminal voltage varies linearly with SVC current or reactive power, as the latter is varied over its entire capacitive-to-inductive range.

Overcurrent Limit To prevent the thyristor valves from being subjected to excessive thermal stresses, the maximum inductive current in the overload range is constrained to a constant value by an additional control action.

Modelling of Static Var Compensator

The Static VAR Compensator (SVC) is a shunt connected device whose main functionality is to regulate the voltage at a chosen bus by suitable control of its equivalent reactance. A basic topology consists of a series capacitor bank, C, in parallel with a thyristor-controlled reactor, L, as shown in Figure 11. In practice the SVC can be seen as an adjustable reactance that can perform both inductive and capacitive compensation.

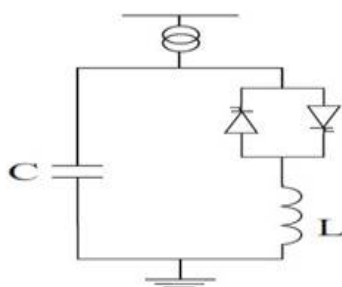

Figure 11 Basic SVC topology

The SVC voltage regulator processes the measured system variables and generates an output signal that is proportional to the desired reactive-power compensation. Different control variables and transfer functions of the voltage regulator are used, depending on the specific SVC application. The measured control variables are compared with a reference signal, usually V_{ref} , and an error signal is input to PI controller. The output of the controller is a per-unit susceptance signal B_{ref} , which is generated to reduce the error signal to zero in the steady state. The susceptance signal is subsequently transmitted to the gate pulse–generation circuit.



International Journal of Advanced Research in Electrical, Electronics and Instrumentation Engineering

(An ISO 3297: 2007 Certified Organization)

Vol. 5, Issue 6, June 2016

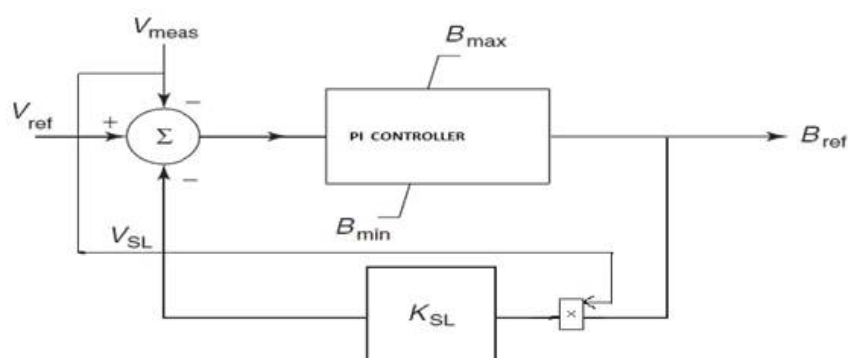

Fig.12 SVC PI control scheme

A small slope or droop (3–5%) is typically incorporated into the steady-state characteristics of SVCs to achieve specific advantages. Alternative implementations of this slope in the PI controller model are illustrated in Fig. 12; the susceptance in pu is multiplied with measured voltage the current droop-feedback arrangement is depicted in Fig.12. The SVC current is explicitly measured and multiplied by a factor K_{SL} representing current droop before feeding as a signal V_{SL} to the summing junction. The sign of V_{SL} is such that it corresponds to an increase of reference voltage for inductive SVC currents and a decrease of the reference voltage for capacitive SVC currents. Simple integral control finds most common usage in voltage controllers. RR is termed the response rate, which is indicative of the time taken by an SVC to move across its entire reactive-power range, that is, from a fully capacitive to a fully inductive state, in response to a large (1-pu) voltage error.

In certain cases, it may be difficult to faithfully obtain the current signal. This occurs when the SVC is operating close to its floating state, that is, zero MVA reactive power. The current signal then comprises a predominant harmonic component and a fundamental resistive component corresponding to the real losses in SVC. To overcome this problem, in certain SVC controllers the reactive power is computed and fed back instead of using the SVC current. The reactive-power signal is calculated by multiplying the phase currents in SVC by a fundamental frequency voltage lagging behind the actual phase voltage by 90° . It is implicitly assumed that the SVC bus voltage remains close to 1 pu thus the SVC current that is strictly equal to B_{ref} .

V. CONCLUSION

From the study of above FACTS devices it can be concluded that every device has its own specialty and all devices have different practical implementation aspect. On the basis of their V-I characteristic and application we can say that SVC is better than TSCS, TSCS is better than SSSC.

REFERENCES

- [1] H.F. Wang, Proposed Design of damping controller to improve power system oscillations stability, IEEE transactions on power delivery isbn no 0-7803-5546-6/99 year 1999.
- [2] Pranesh rao ,M.L. Crow ,Defined STATCOM control for power system voltage control applications IEEE transactions on power delivery Vol 15 no.4 oct.2000.
- [3] N.G. Hingorani and L.Gyugi, Understanding FACTS – Concepts and Technology of flexible ac transmission system, standard publishers Distributors ,IEEE papers ,new York 2001.
- [4] K.R. Padiyar ,2002, Power system dynamic stability and control second edition, BS publication hyderabad.
- [5] Sidhartha Panda,R.N. Patel, Proposed Improving power system transient stability using on/off shunt FACTS devices, Journal of electrical engineering vol.57 no 6 year 2006.
- [6] Mathias wien, Proposed performance analysis of SVC, IEEE transactions on power delivery vol 17 no.9 year 2007.
- [7] Prabha Kundur,John Preseba ,Definition and classification of power system stability, IEEE transactions on power system year 2008.
- [8] M.reyes,S.vazquez,M.B. Ferrera , Proposed voltage measurement control of a SSSC, IEEE transaction on power delivery ISBN-978-1-4244-6392-3/10 year 2010.
- [9] A.S. Kannan, R.Kayalvizhi, Proposed Novel design of a fuzzy coordinated SSSC controller for integrated power system ,IJPTE journal ISSN 2077-3528 vol.3 year 2011.
- [10] M.Faridi, H.Maeiat, proposed Power system stability enhancement using SSSC, ISBN-978-1-61284-840-2/11 year 2011.