



e-ISSN: 2278-8875
p-ISSN: 2320-3765

International Journal of Advanced Research

in Electrical, Electronics and Instrumentation Engineering

Volume 14, Issue 1, January 2025

ISSN INTERNATIONAL
STANDARD
SERIAL
NUMBER
INDIA

Impact Factor: 8.514

☎ 9940 572 462

☎ 6381 907 438

✉ ijareeie@gmail.com

@ www.ijareeie.com



A New Perspective on the Conservation of Rain Water and the Generation of Electrical Energy

Hemanth Kumar. T

Lecturer & Head of the Department, Department of Electrical & Electronics Engineering, Hanagal Sri Kumareshwara Polytechnic (H.S.K Polytechnic), (Formerly V. V. Sangha's Polytechnic), Ballari, Karnataka, India

ABSTRACT: In this topic an effort is made on harvesting the rainwater for generating an electrical energy. Main objective of this work is to overcome the water and power problems in urban areas especially in factories, multiplexes, apartments and hospitals etc. The space between the two skyscrapers can be utilized to install a trolley balanced by a counter weight, such that it is initially held at the top of the building. When there is a rainfall the trolley gets filled up with the rain water. Once the weight of the trolley exceeds the counter weight the trolley starts to descend. When descending a special pulley arrangement driven by chain is designed. The pulley is coupled to a generator which generates electricity. At the ground level a wedge is provided that causes the trolley to empty the water in to the sump. When the water is completely drained the trolley automatically ascends up to its original position during ascending also electricity is produced. In this work power is generated through gear mechanism system by using Traction drive and Geared DC generator. Generated power can also stored using rechargeable battery which is used as backup during any interruption occurs. An illumination control is also designed with a comparator and microcontroller chip. In this work saving of energy and effective utilization of power are the important outcome factors.

KEYWORDS: Traction drive, Electricity, Illumination, skyscraper, servomotor.

I. INTRODUCTION

Energy is a major input for all socio-economic development of any society. Hydel energy is the fastest growing conventional energy. Hydel technology has improved significantly over the past two decades, and energy has become increasingly competitive with other power generation options. Hydropower plants are installed in more than 150 countries, over 32% of hydro power is generating in Asia-Pacific region only. China is leading country in the generation of hydro electric power (approximately 721 terawatt hours).

Micro Hydroelectricity is the term referring to electricity generated through rain water harvesting concept. The electrical power can be generated by using gravitational force which is present in the falling water. It is the most widely used form of renewable energy, accounting for 16 percent of global electricity generation more than 3,427 terawatt-hours of electricity production till 2015, and is expected to increase about 3.1% each year for the next 25 years.

In hydroelectric power generation, water is the main source hydraulic energy is converting in to mechanical energy this inturn converts into electrical energy by using alternator (AC Generator). The production of Electricity depends on the flow of water from zenith sources.

II. METHODOLOGY

The methodology follows with various sections in step by step as shown in Fig.1. The main components of block diagram are Traction drive, Geared DC Generator, unidirectional/bidirectional current controller, rechargeable battery and illumination Control unit.

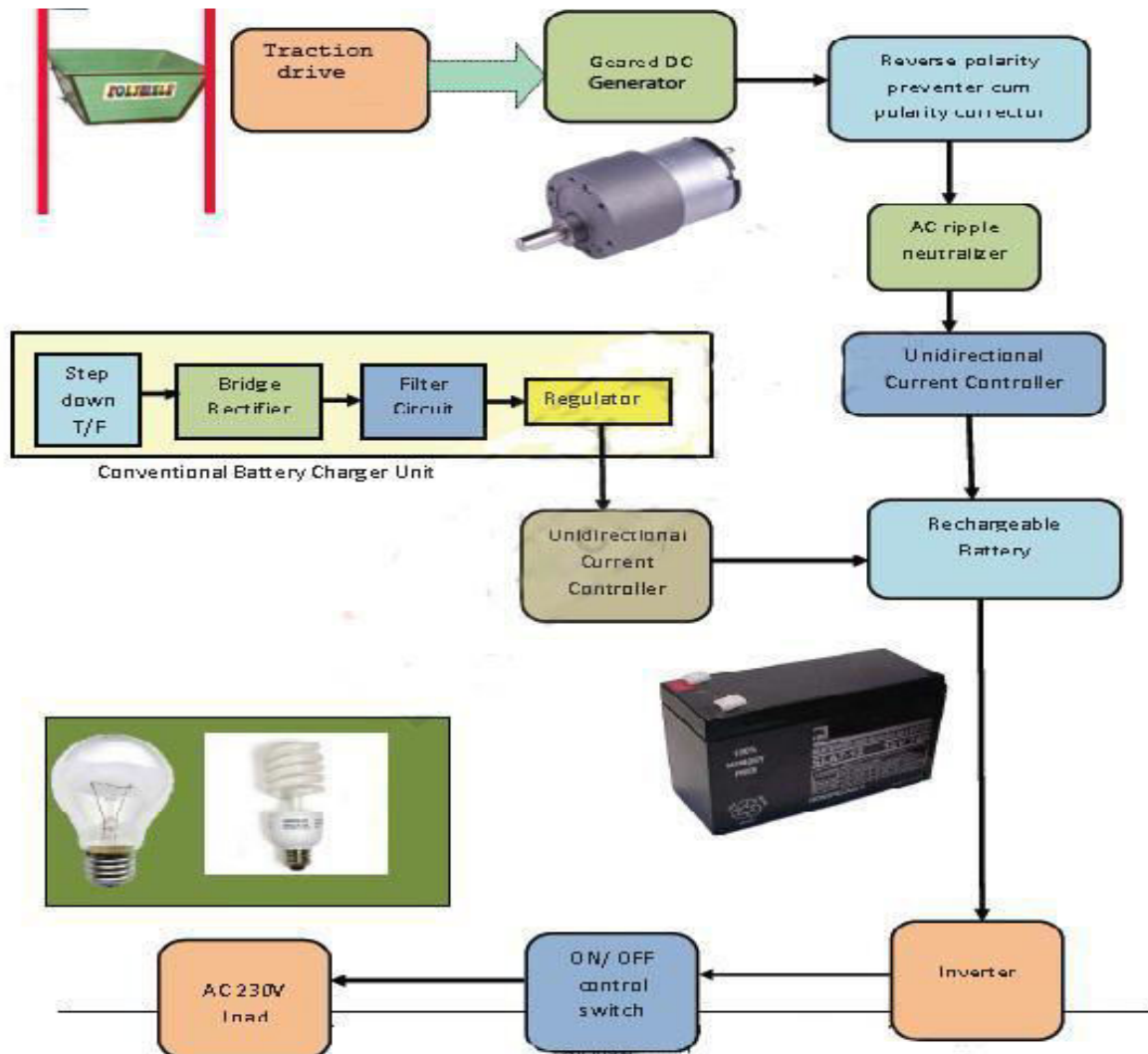

Fig 1: Block Diagram of Implementation of Rain Water Harvesting and Power Generation

2.1 TRACTION MOTORS:

The motor chosen in this work is very small typically used in a toy.



Fig 2: Dissected Motor



Fig 2 shows a small motor outer most part is steel frame which gives protection and mechanical support to the field system. There is an axle, a nylon end cap and two battery leads. The leads from the armature of the motor are connected to a flashlight battery, the axle will rotate in clockwise. If polarities of the leads are reversed, then it will rotate in counter clockwise direction. Here two other views of the same motor are shown.

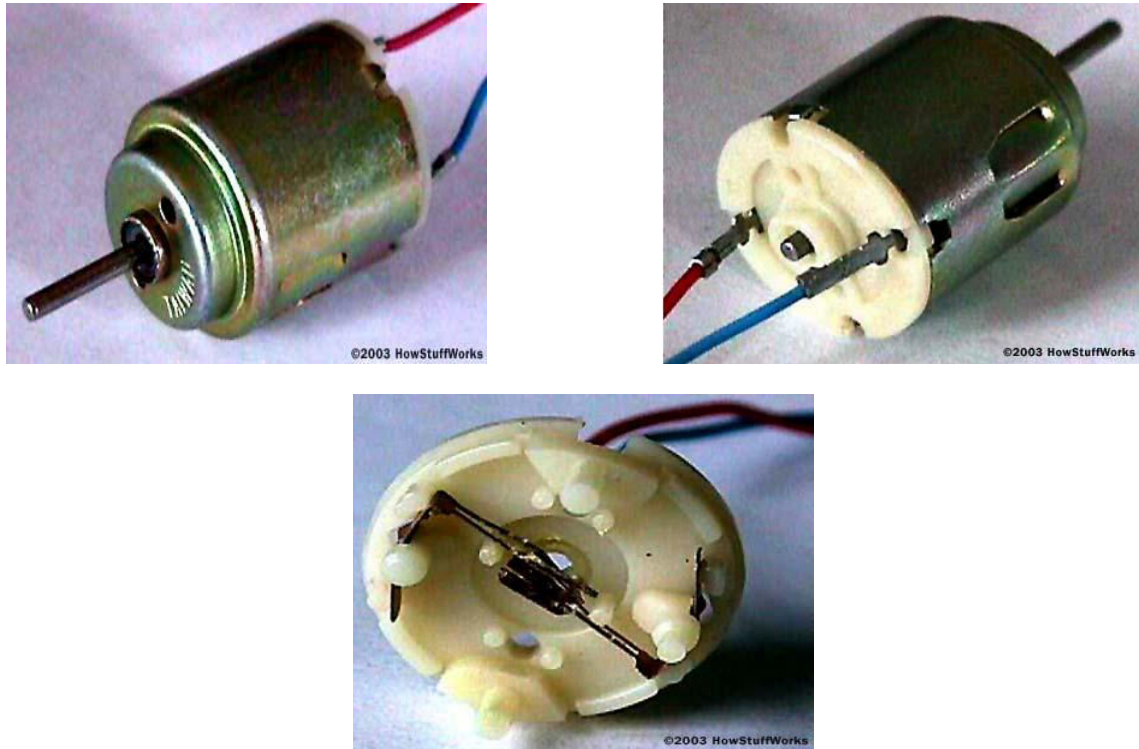

Fig 3: Nylon End Caps

Geared DC motor is used for vertical to and fro motion of elevator. It collects PWM pulses from the microcontroller and accordingly maintains speed of the elevator.



Fig 4: Geared DC Motor

Technical specifications: Rated Voltage 12V, Operating Voltage Range 3V-12V, Current at no load 50mA, Current at full load 500mA, Gear ratio is 50 :1, Motor Shaft Speed: 100 RPM , Torque 2.7 Kg-cm.



2.2 SERVO MOTOR BLOCK DIAGRAM:

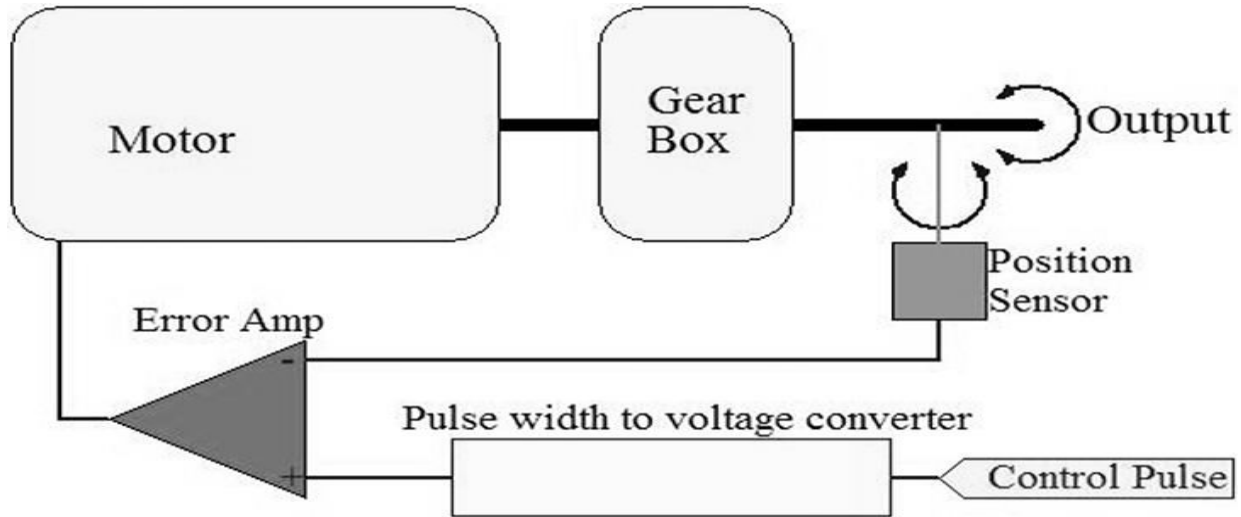

Fig 5: Servo Motor Block Diagram

The Brake actuators comprises of Precision servo motor operating at 5V and a brake mechanism. Electrical control unit (ECU) applies brake by providing PWM pulses to Servo motor. Servo motor angle can be defined by using PWM signals. The advantage of servo motor is precision braking by applying appropriate pressure to brake pads. Servo is a small device that has an output shaft, which can be positioned to specific angular positions by sending the servo coded signal. As long as the coded signal exists on the input line, the servo will maintain the angular position of the shaft. As the coded signal changes, the angular position of the shaft changes.

Technical specifications: Operating Voltage 5V, Operating Current 500mA max. Speed 60 RPM, Torque 5Kg-cm, Weight 120 grams.

2.3 ILLUMINATION CONTROL:

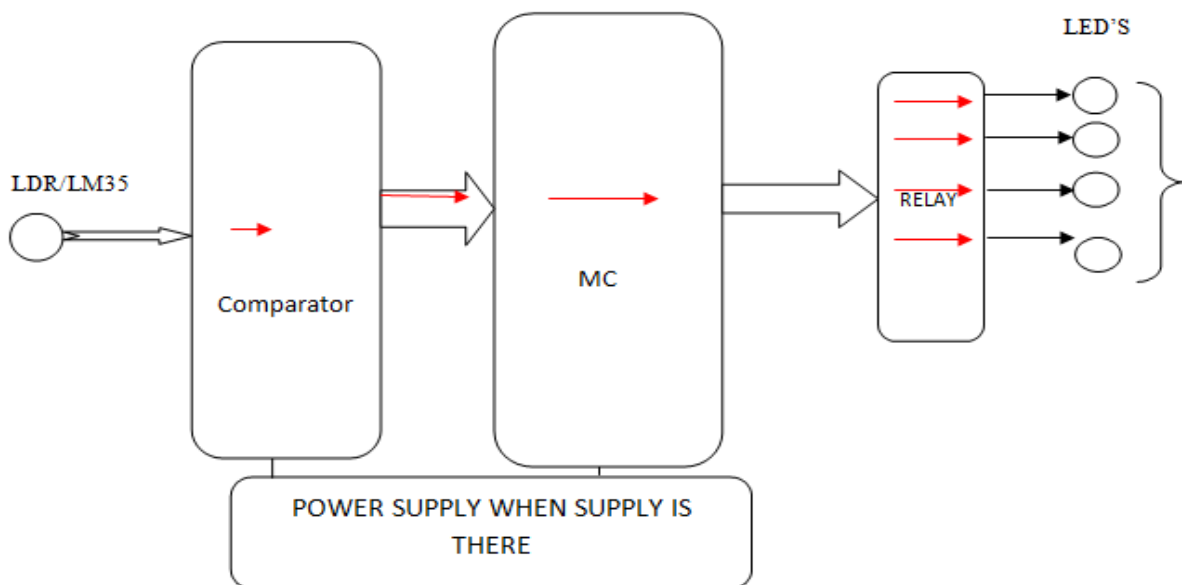

Fig 6: Block Diagram of Illumination Control



PIN DESCRIPTION AND ARCHITECTURE OF 8051:

Introducing the Intel’s Microcontroller 89C51

FEATURES: 4KB of In-System Reprogrammable Flash Memory, Endurance: 1,000 Write/Erase Cycles, Fully Static Operation: 0 Hz to 24 MHz, 128x 8-bit Internal RAM.

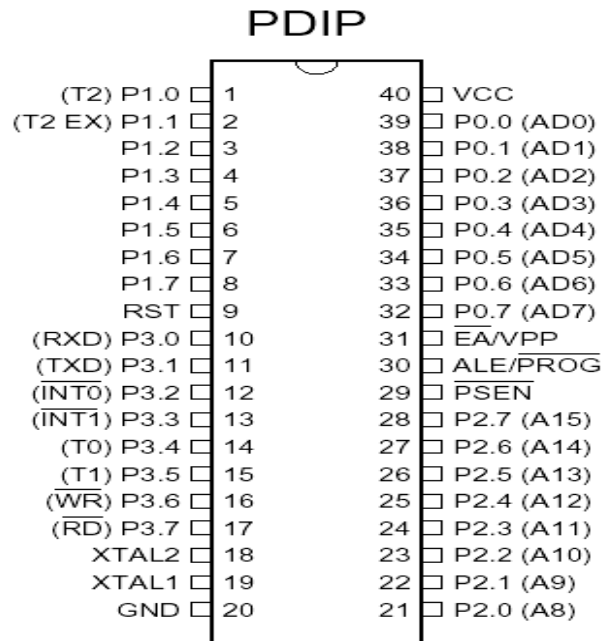

Fig 8: Pin Configuration of 8051 Micro - Controller

The AT89C51 is a low-power, high-performance CMOS 8-bit microcomputer with 4KB of Flash programmable and erasable read only memory (PEROM). The device is manufactured using Atmel’s high-density nonvolatile memory technology and is Compatible with the industry-standard 80C51 and 80C52 instruction set and pin out. The on-chip Flash allows the program memory to be reprogrammed in-system or by a conventional nonvolatile memory programmer.



III. RESULTS AND DISCUSSION



Fig 9. (a) Sky Scrapers with Gear Mechanism Module

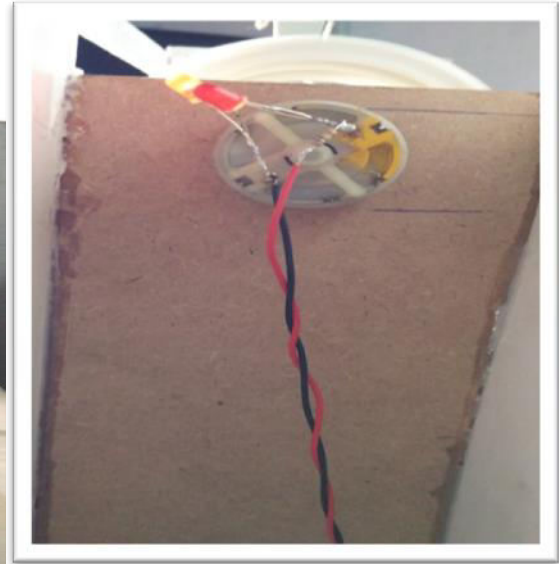

Fig 9. (b) Generated Electrical Power

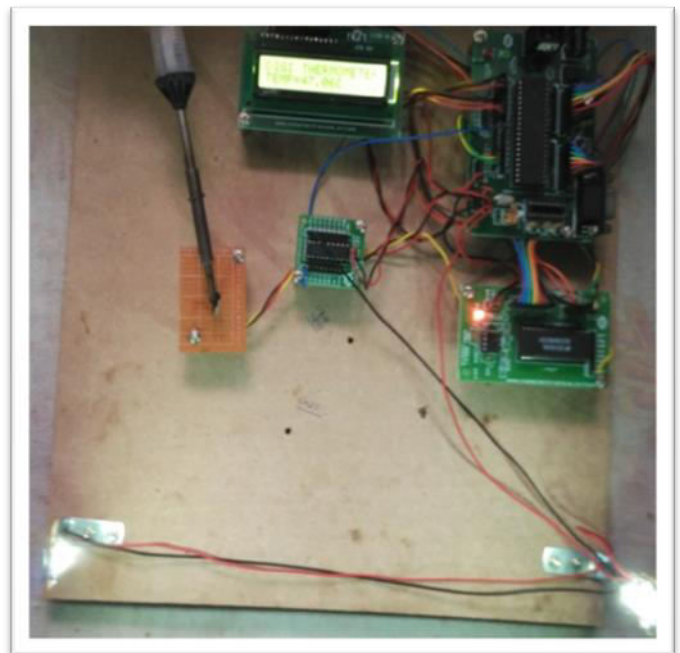
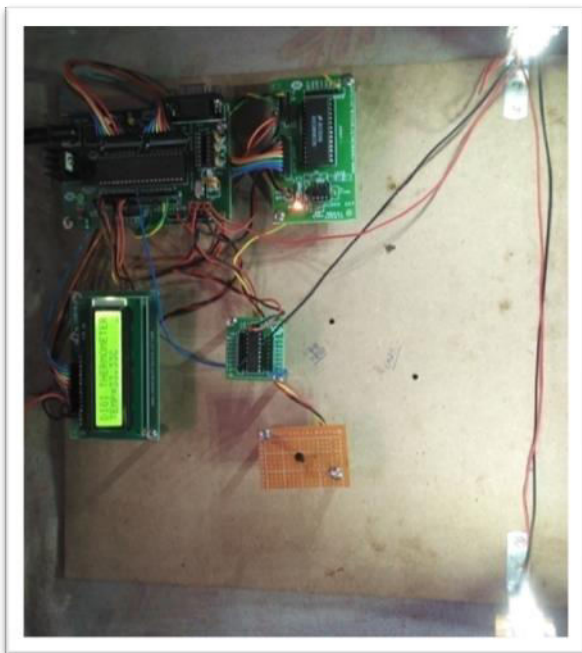

Fig 10: Illumination Control Unit Output Module



||Volume 14, Issue 1, January 2025||

|DOI:10.15662/IJAREEIE.2025.1401007|

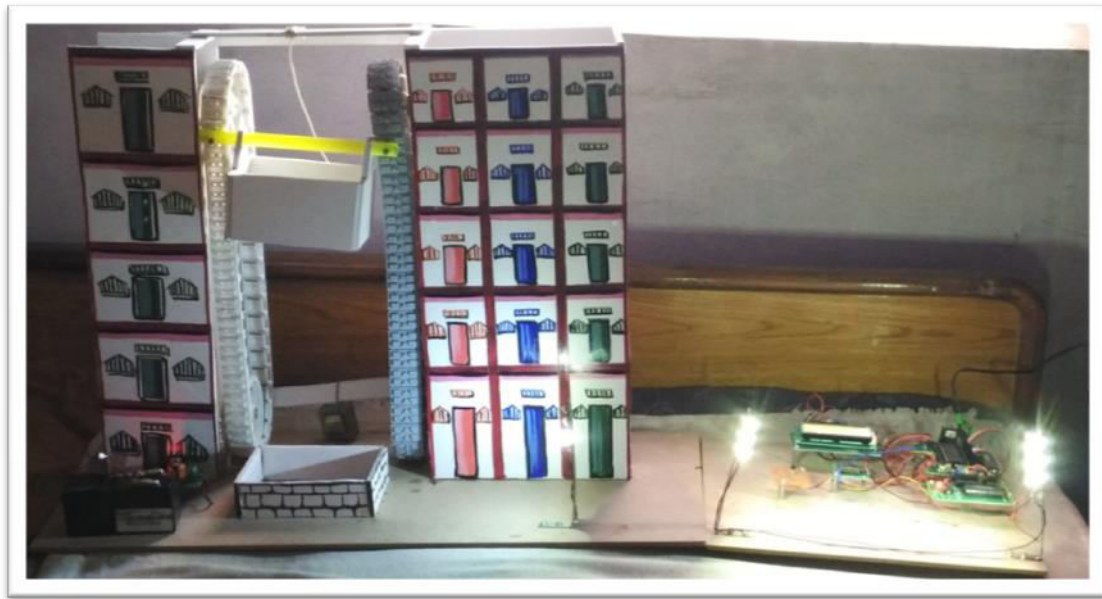

Fig 11: Overall Project Module & Circuit

Figure 9. (a) and 9. (b) shows the Generated voltage obtained at the Output after conversion from Gear Mechanical Energy into Electrical Energy is about 3 V. This generated voltage is Stepped up to 12V by using Buck-boost regulator and LM317IC which is shown in fig 9.(a). Then this regulated voltage is stored in a rechargeable battery. This stored energy can be used in emergency.

Figure 10. Shows the illumination control units in which it senses the room temperature if its value is less than reference value (45 degree celsius) then all array of LED's will be switched ON. Incase if it increases beyond reference value then array of LED's will be automatically switched ON according to the illumination requirement.

IV. CONCLUSION

It is completely a GO-GREEN project & eco-friendly without any pollution. This technique helps to increase the under ground water level. This work can be developed in urban areas wherever tall buildings are available and also in between hillocks. It is flexible, low power costs, reduced CO₂ emissions.

REFERENCES

- [1] "US Energy Information Administration," M. Bowles, State Electricity Profiles 2008,DOE/EIA 0348(01)/2, March 2010.
- [2] "Trends in Consumption and Production: Household Energy Consumption," O. Dzioubinski and R. Chipman, United Nations Department of Economic and Social Affairs, ST/ESA/1999/DP.6, April 1999.
- [3] "Electricity Use in California: Past Trends and Present Usage Patterns," R. Brown and J. Koomey, Energy Policy 31, 849 (2003).
- [4] "The Terminal Velocity of Fall for Water Droplets in Stagnant Air," R. Gunn and G. D. Kinzer, J. Atmosph. Sci. 6, 243 (1949).
- [5]. "Harvesting Raindrop Energy: Experimental Study," R. Guigon et al Smart Materials and Structures 17, 015039 (2008).
- [6] "Harvesting Raindrop Energy: Theory," R. Guigon et al. Smart Materials and Structures 17, 091038 (2008).
- [7] Flood "Weather And Climate Extremes," P. F. Krause and K. L. US Army Corps of Engineers, Technical Report TEC-0099, September 1997.
- [8] "The 8051 Microcontroller and Embedded Systems-using Assembly and C",-Muhammad Ali Mazidi and Janice Gillespie Mazidi and Rollin D. McKinlay; Pearson 2013.
- [9] "Power Electronics & Hardware Details", - M.H.Rashid, Pearson, 3rd Edition 2013.

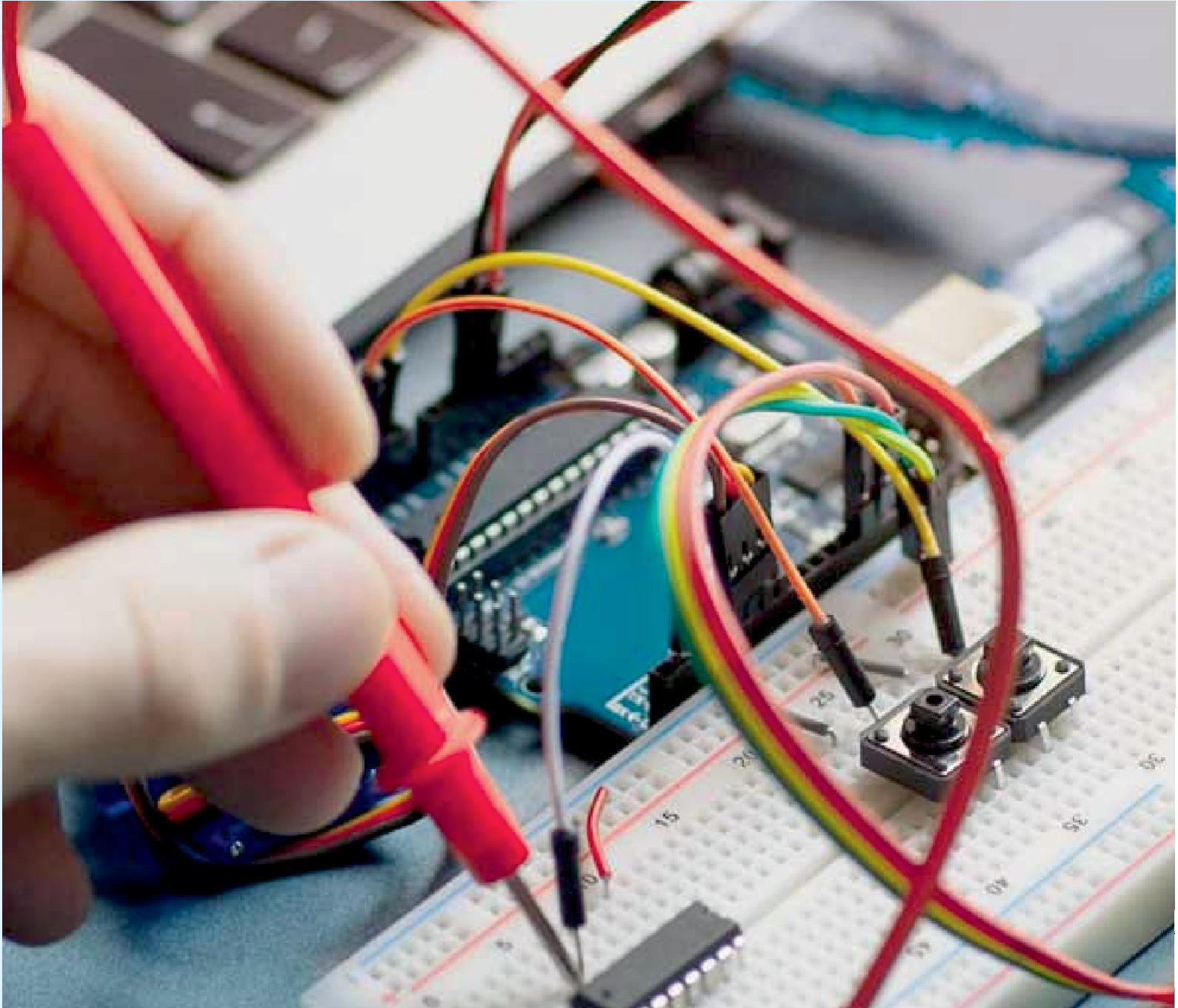

INNO  SPACE
SJIF Scientific Journal Impact Factor

 **doi**[®]
cross **ref**

 **INTERNATIONAL
STANDARD
SERIAL
NUMBER
INDIA**



International Journal of Advanced Research

in Electrical, Electronics and Instrumentation Engineering

 9940 572 462  6381 907 438  ijareeie@gmail.com



www.ijareeie.com

Scan to save the contact details