



ISSN (Print) : 2320 – 3765  
ISSN (Online): 2278 – 8875

## International Journal of Advanced Research in Electrical, Electronics and Instrumentation Engineering

(A High Impact Factor, Monthly, Peer Reviewed Journal)

Website: [www.ijareeie.com](http://www.ijareeie.com)

Vol. 9, Issue 2, February 2020

# Design and Implementation of Ball and Beam System Using PID Controller and Development of Graphical User Interface Using LabVIEW

S.Anitha<sup>1</sup>, B.Irfhanna Ameer<sup>2</sup>, G.Kirthika<sup>3</sup>, S.Logeshwari<sup>4</sup> and Dr.S.M Girirajkumar<sup>5</sup>

UG Scholar, Department of Instrumentation and Control Engineering, Saranathan College of Engineering,  
Tamil Nadu, India<sup>1,2,3,4</sup>

Professor, Department of Instrumentation and Control Engineering, Saranathan College of Engineering, Tamil Nadu, India<sup>5</sup>

**ABSTRACT:** The ball and beam system is widely used as a tool for learning traditional as well as advanced control techniques. The system with highly nonlinear characteristics is an excellent tool to represent unstable systems. This paper represents an optimal control strategy for controlling the position of ball on the beam by comparing the various optimization algorithms like Zeigler-Nichols, Cohen-Coon and Genetic Algorithm. This system is an open loop non-linear system. The whole system could be implemented by employing a servo motor, an Infrared distance sensor, a processor and a support assembly. The system is designed with two Degrees-of Freedom. The nonlinear characteristic of the higher order system is regulated by using PID controller. The control problem is a challenging one as the ball position continuously varies with the beam angle. The control strategy includes PID control for both ball position (beam angle) and servo position control. The control parameters are tuned using optimal method. Then the results are verified experimentally using real time ball and beam system.

**KEYWORDS:** Optimization algorithms, higher order system, PID controller, ball and beam.

### I.INTRODUCTION

Ball and beam system is a special design to imitate the stability of a non-linear system such as ship control mechanism and horizontally stabilizing an airplane during landing and in turbulent air flow. As the name indicates, a ball is placed on a beam and the controller should tend to balance the ball at desired position on the beam as given by the user. Since the ball position is highly unstable in open-loop, there is a need for a feedback loop with a suitable controller to minimize the instability. The work of a controller should is to provide least possible transients in the step-response, while minimizing the steady-state error. [12] The ball-beam system is a bench mark example in control systems. A stepper motor, which is pivoted at the centre of the beam is used to control the position of the ball along with an accelerometer sensor which provides information related to the orientation of the beam. Thus, as the ball moves to an external disturbance, the angle of the beam is changed to counteract this change.

### II. LITERATURE SURVEY

This system consists of two segments which are ball and beam body and system for motor control. The ball and beam system have two degree of freedom (DOFs). It is hard to control the position of the ball because the ball continuously moves on the beam. In addition, the ball movement increase without limit for angle of beam, the system become open-loop unstable system, so the main purpose of the controller is to control the location of the stainless steel ball by adjusting the



# International Journal of Advanced Research in Electrical, Electronics and Instrumentation Engineering

(A High Impact Factor, Monthly, Peer Reviewed Journal)

Website: [www.ijareeie.com](http://www.ijareeie.com)

Vol. 9, Issue 2, February 2020

rotating angle of the motor that is connected to the beam. [8] There are various traditional algorithms that could produce optimal value of proportional, derivative and integral gain values of the controller. Some of them includes: Ziegler-Nichol's method, Gain & phase margin tuning method, ITAE equations method, SISO tool and so on. [12] The modern control algorithms such as GA, PSO, SA, fuzzy logic and neural network paves a way of breaking the complicated non-linear system into a controllable one. Genetic Algorithm is an adaptive search technique, based on the principles of natural genetics and natural selection, which, in control engineering, can be used as an optimization tool or as the basis of more general adaptive systems. They operate on a population of current approximations initially drawn at random, from which improvement is sought. [6] Thus, this project is a combined study of both traditional and modern control algorithms to facilitate the stability of the chosen real time problem. By comparing the algorithms, the optimal control value can be obtained. This paper also deals with the design methodology of the real time ball and beam system and its stability analysis.

The main objective of this project is listed as follows, the mathematical model of the system is obtained. Initially set point is decided using the data collected by analyzing the output from the position sensor. The necessary constant values are determined and PID controller is tuned in LabVIEW using Modified ZN, CC and GA algorithms. The output is given to a servo motor for necessary control actions. By regulating the voltage supply to the servomotor, the position of the ball can be maintained without oscillations.

### III. SYSTEM ALGORITHM FOR TUNING THE PID CONTROLLER.

Most of the industrial process must be controlled in order to run safely and efficiently. To design controller, mathematical model of the process is required. Especially for design of an optimal controller the selected model must be able to describe the properties of the disturbance acting on the process.

#### I. ZIEGLER-NICHOLS TUNING:

This method is applied for the systems with step responses. This type of response is typical for a first order system with transportation time delay. The response is characterized by two parameters,  $\alpha$  delay time and  $\tau$  the time constant. These are found by drawing a tangent to the step response of the system. The mathematical model is described as

$$G(S) = \frac{k e^{-\alpha t}}{\tau s + 1}$$

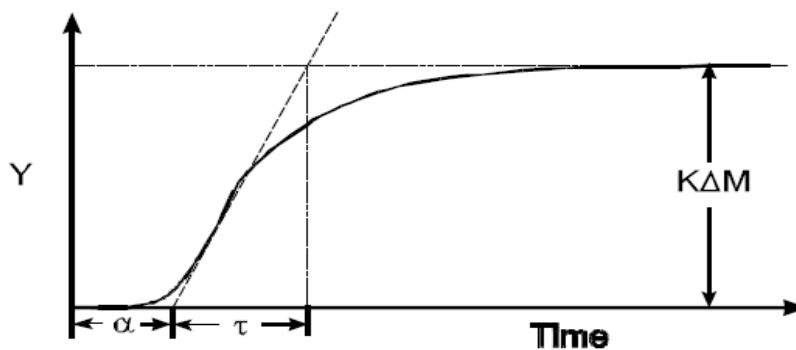

Fig.1 Response curve for Zeigler-Nichols I tuning method.

In real-time process control systems, a wide range of systems can be approximately modeled by any of the mathematical modeling. If the system model cannot be derived, experiments can be performed to obtain the parameters for the approximate model of the system. For instance, if the step response of the system model can be measured through an



# International Journal of Advanced Research in Electrical, Electronics and Instrumentation Engineering

(A High Impact Factor, Monthly, Peer Reviewed Journal)

Website: [www.ijareeie.com](http://www.ijareeie.com)

Vol. 9, Issue 2, February 2020

experiment, the output signal can be plotted as represented in fig.1 where Y is the process variable , from which the parameters of k,  $\alpha$ , and  $\tau$  can be obtained as shown in the diagram. With  $\alpha$  and  $\tau$  , the Ziegler-Nichols formulas can be used to get the controller parameters.

Ziegler-Nichols tuning method			
Controller Type	$K_c$	$T_i$	$T_d$
PID	$\frac{1.2}{k} \left( \frac{\tau}{\alpha} \right)$	$2.0\alpha$	$0.5\alpha$

## II.MODIFIED ZIEGLER-NICHOLS TUNING METHOD:

Modified Ziegler-Nichols tuning algorithm emphasizes on set point regulation. In addition to it, one qualitative specification is that the system response speed and overshoot can be accommodated. Comparing with the traditional Ziegler-Nichols tuning formula, this method uses the time constant  $\tau$  of the plant explicitly. The modified Zeigler-Nichols tuning method for PID controller tuning formulas are summarized in the below table for set-point regulation.

To obtain the PID values, the controller must be put into P mode and the gain is increased until the process show sustained oscillation which is shown in fig.2. As the process model is known, the gain and phase models may be directly obtained from the system. Using the values of  $K_u$  and  $P_u$  obtained, the controller parameters are calculated using the ZN-II rules. The frequency of continuous oscillation  $\omega_c$  and the amplitude M of the system response at crossover frequency should be obtained. To compute ultimate gain  $K_u=1/M$  and ultimate period  $P_u=2\pi/ \omega_c$ .Calculate the PID values from the table using  $P_u$  and  $K_u$ .

Modified Ziegler-Nichols tuning method			
Controller Type	$K_c$	$T_i$	$T_d$
PID	$0.6K_u$	$P_u/2$	$P_u/8$

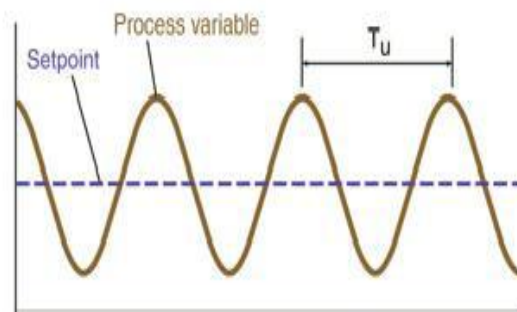

Fig.2. Sustained oscillations obtained by closed loop system.



## International Journal of Advanced Research in Electrical, Electronics and Instrumentation Engineering

(A High Impact Factor, Monthly, Peer Reviewed Journal)

Website: [www.ijareeie.com](http://www.ijareeie.com)

Vol. 9, Issue 2, February 2020

### III.COHEN-COON TUNING METHOD:

The Cohen-Coon tuning method is suitable for self-regulating processes. Modified Cohen-Coon tuning rules are an excellent method for achieving fast response on all control loops with self-regulating process. They are an effective and highly reliable alternative to the ZN tuning method, which does not works well when applied to many self-regulating processes. The process reaction curve is an approximate model, assuming the process behaves as a first order with dead time system. The process reaction curve which is shown fig.1 is identified by doing an open loop test of the process for identifying the process model parameters. After finding the process model the controller can be modeled using Cohen-coon method to tune the controller by the formulas as follows.

<b>Cohen-Coon tuning method</b>			
<b>Controller Type</b>	$K_c$	$T_i$	$T_d$
PID	$\frac{1}{k} \left( \frac{\tau}{\alpha} \right) \left[ \frac{4}{3} + \frac{1}{4} \left( \frac{\alpha}{\tau} \right) \right]$	$\alpha \left[ \frac{32 + 6 \left( \frac{\alpha}{\tau} \right)}{13 + 8 \left( \frac{\alpha}{\tau} \right)} \right]$	$\alpha \left[ \frac{4}{11 + 2 \left( \frac{\alpha}{\tau} \right)} \right]$

### IV.GENETIC ALGORITHM:

A Genetic Algorithm is typically initialized with a randomly generated population consisting of individuals. Each individual in the population is usually represented by a real-valued number or a binary string. Such strings are called as chromosomes. A set of chromosome or individual is called as a whole population. Performance of each individual is measured and assessed by the objective membership function. The objective function assigns each individual a corresponding number called its fitness value using descent gradient curve. If the termination criteria are not met with the current population then new individuals are created with genetic operators. A survival of the fittest strategy is applied on individuals. The fittest parents are found out by reproduction or selection operator. New individuals are generated by performing operations such as crossover and mutation on the individuals whose fitness has just been measured. The fitness of the offspring is then computed. The offspring is inserted into the population replacing the parents or low-fitness individuals producing a new generation. This cycle is performed until the termination criterion is reached. Such a single population GA is powerful and performs well on a wide variety of problem. Every iteration of Genetic Algorithm loop is referred as a generation. When termination criteria gets satisfied GA stops.

The GA operators such as selection,crossover and mutation are performed for each iteration. In selection the chromosome with the higher fitness value is selected. Fitness value is assigned based on the weight of the chromosome. In the crossover process the offspring will have the characters which is superior to the parent chromosome. Mutation maintains the genetic diversity between the each generations.



# International Journal of Advanced Research in Electrical, Electronics and Instrumentation Engineering

(A High Impact Factor, Monthly, Peer Reviewed Journal)

Website: [www.ijareeie.com](http://www.ijareeie.com)

Vol. 9, Issue 2, February 2020

## IV. MATHEMATICAL MODELLING OF BALL AND BEAM SETUP:

The ball and beam model consists of a horizontal beam and a DC servomotor mechanically attached at the one end of the beam. The angle of the beam is controlled by the servomotor. The angle in turn controls the position of the ball.

### A. Mathematical Model Composition:

The process model can be derived into two separate models as follows

- I. Model for the angle of the beam with respect to the motor voltage  $H_\phi(s)$
- II. Model of the position with respect to the beam angle  $H_x(s)$

The total transfer function from the input voltage to the controlled voltage that indicates the ball position is then,

$$H(s) = H_\phi(s) \times H_x(s)$$

### B. Mathematical Model Derivation:

a) Model of beam angle vs. input voltage:

The relationship between the input voltage and the angle of the beam is defined by the transfer function of the DC servomotor. The DC servomotor is used for angle control applications.

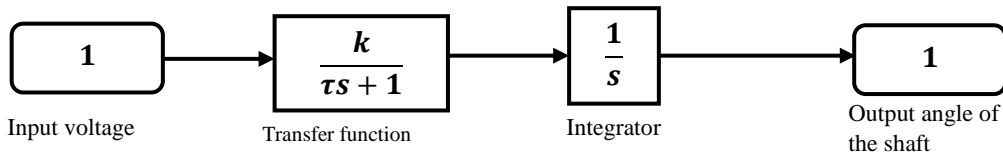

Fig.3. General DC motor block diagram for angle control application

The K denotes the motor constant and the  $\tau$  is the motor time constant. The actual model of the motor used for the project is shown in figure 5.

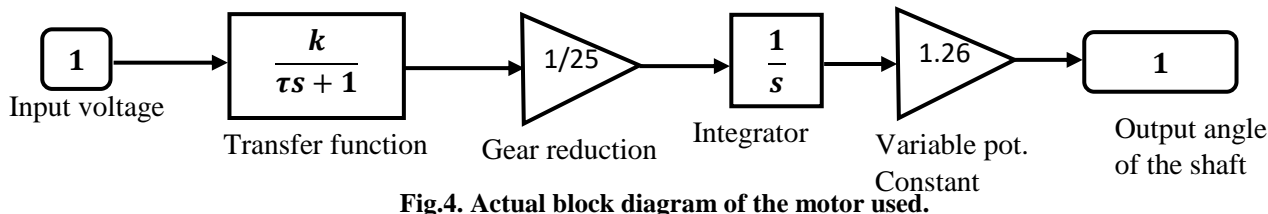

Fig.4. Actual block diagram of the motor used.

The measured constants are summarized as shown:

$$K_m = 229 \text{ rad/sec/V}$$

$$\tau = 0.4 \text{ sec}$$



## International Journal of Advanced Research in Electrical, Electronics and Instrumentation Engineering

(A High Impact Factor, Monthly, Peer Reviewed Journal)

Website: [www.ijareeie.com](http://www.ijareeie.com)

Vol. 9, Issue 2, February 2020

$$K_{gear} = 1/25$$

$$K_{variable\ pot} = 1.26\ rad/V$$

Therefore the motor transfer function becomes

$$\frac{\theta(s)}{V(s)} = \frac{11.54}{s(1 + 0.4s)}$$

b) Model of ball position vs. beam angle:

Consider the following sketch,

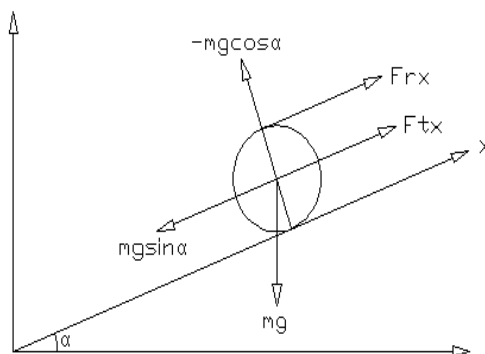

Fig.5.Rolling ball free-body diagram

The inclination is considered the x-coordinate. Let acceleration of the ball be denoted as

$$\frac{d^2x}{dt^2} = \ddot{x}$$

The force due to translational motion is then

$$Ftx = m\ddot{x}$$

The torque which is developed through the rotation of the ball is determined by the force at the edge of the ball and it is multiplied by the radius and it can be further expressed as:

$$T_r = F_{rx}R = J \frac{dw_b}{dt} = J \frac{d(v_b/R)}{dt} = J \frac{d^2(x/R)}{dt^2} = \frac{J}{R} x''$$

Where,

J = Moment of Inertia (for solid ball it is defined by  $J=2/5*mR^2$ )

$W_b$ =angular velocity of the ball

# International Journal of Advanced Research in Electrical, Electronics and Instrumentation Engineering

(A High Impact Factor, Monthly, Peer Reviewed Journal)

Website: [www.ijareeie.com](http://www.ijareeie.com)

Vol. 9, Issue 2, February 2020

$V_b$ = speed of the ball along x axis

$$\frac{X(s)}{\theta(s)} = \frac{0.91}{s^2}$$

The constant in the numerator is a theoretical constant that neglects surface imperfections and frictional effects. The measured constant is approximately 0.91 therefore the transfer function of the ball position. Now the overall transfer function of the system can be stated as

$$H(s) = \frac{\theta(s)}{V(s)} \times \frac{X(s)}{\theta(s)} = \frac{10.5}{s^3(0.4s + 1)}$$

Where, 10.5 is an approximated constant.

## V. HARDWARE IMPLEMENTATION OF BALL AND BEAM SYSTEM

The major components of the project comprises of the following:

1. Beam as controlling structure
2. Motor as controller
3. Ball as control element

In the control mechanism, Ball acts as a non-linear system when it is placed on a linearly moving beam. The beam is connected with the servo motor that is controlled by Pulse Width Modulation technique i.e. PWM signals. The beam is made up of light weight cardboard sheet in order for the motor to make movement on it. The beam width is designed based on the diameter of the ball chosen.

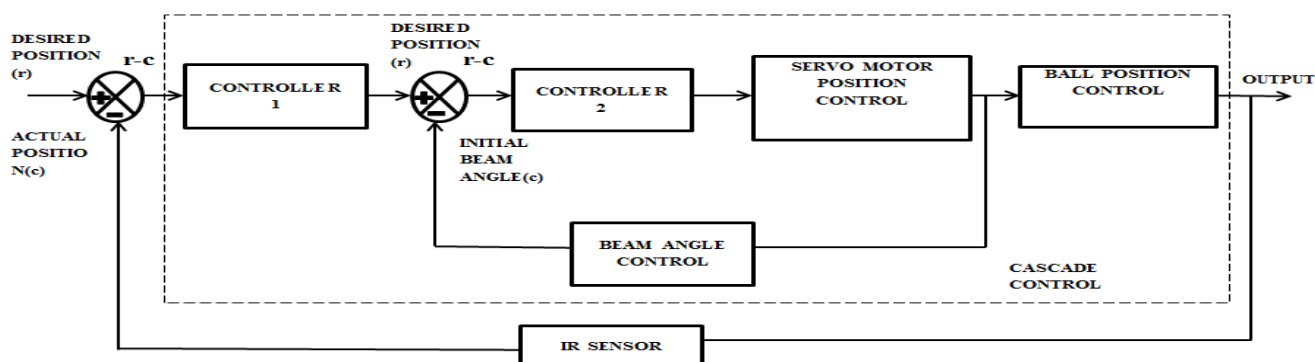

Fig.6. Block Diagram of the ball and beam control system.

The beam connected with the servo motor tends to move up and down along with the axis of motor rotation. The axis of rotation of the motor depends on the PID controllers output ( $k_p, k_i, k_d$ ). This range of PWM signal must be on the range between 0 to 1 for rotation. The ball placed on the beam moves to and forth based on the rotation of the motor.



# International Journal of Advanced Research in Electrical, Electronics and Instrumentation Engineering

(A High Impact Factor, Monthly, Peer Reviewed Journal)

Website: [www.ijareeie.com](http://www.ijareeie.com)

Vol. 9, Issue 2, February 2020

## VI. SYSTEM IMPLEMENTATION

In the ball and beam system, initially the ball is placed on the beam. The position of the ball is detected by the position sensor (i.e. IR sensor). One end of the beam is coupled with the servo motor. If we intend to control the acceleration of the ball, then will have to control the angle of the beam. By using the feedback controller as position of the ball the  $k_p$ ,  $k_i$ ,  $k_d$  values are determined by any of the methods such as Cohen-Coon method and ZN method. Comparing the calculated various values of  $k_p$ ,  $k_i$ ,  $k_d$  from the above methods the best values are chosen. For example, if we use the modified Cohen-Coon method, it provides fast response and is an excellent alternative to Ziegler-Nichols for self-regulating processes.. The PID value which was obtained by the CC algorithm is compared with that of the one derived from Zeigler-Nichols method in various perspectives, namely robustness and stability performances.All the simulations were implemented using MATLAB. After the PID controller generates the control signal and is fed it to the servo motor to calibrate the angle of beam with reference to the error in ball-position from set point.

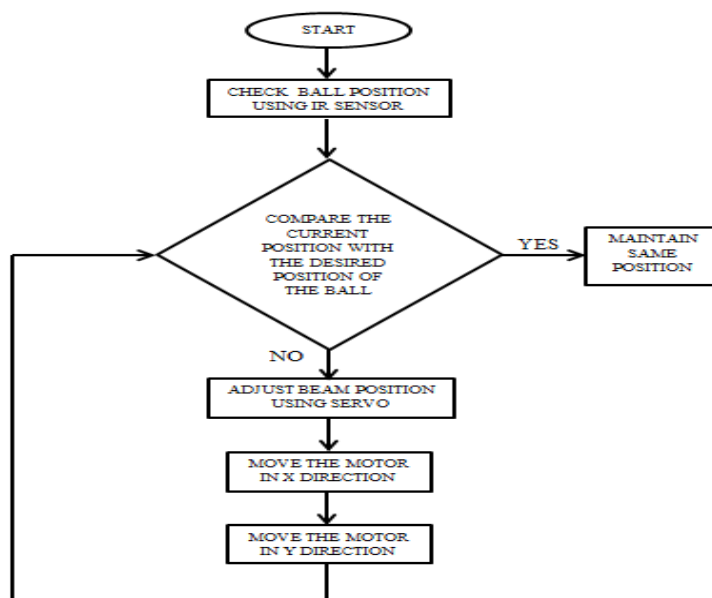

Fig.7.Flow Diagram of the Ball and Beam System.

## VII. SIMULATION RESULTS

The overall transfer function is derived from the mathematical model of the ball and beam system. The ultimate aim of this project is to maintain the system as stable system. The time domain specifications are obtained by executing the Matlab code for ZN and CC method for the systems' transfer function to derive the optimal values for  $k_p$ ,  $k_i$  and  $k_d$ .





## International Journal of Advanced Research in Electrical, Electronics and Instrumentation Engineering

(A High Impact Factor, Monthly, Peer Reviewed Journal)

Website: [www.ijareeie.com](http://www.ijareeie.com)

Vol. 9, Issue 2, February 2020

### TIME DOMAIN SPECIFICATIONS FROM ZN AND CC METHODS:

METHOD	RISE TIME	SETTLING TIME	PEAK OVERSHOOT
CC	1.65	22.7	1.57
ZN-II	2	28	1.162

From the analysis of time domain specifications, CC-PID based tuned controller for system control performs relatively better than the ZN-PID tuning method. Although the two are conventional classical PID controller which requires tuning by experienced personnel, and also require the precise solution to full mathematical model of the system to be controlled, the CC-PID is better in the sense that it gives a reduction in energy consumption due to its low percentage overshoot, rise time and settling time; Therefore Cohen Coon tuning method could be used as a better substitute for the modified Ziegler-Nichols PID (ZN-PID) tuning techniques in the industrial sector.

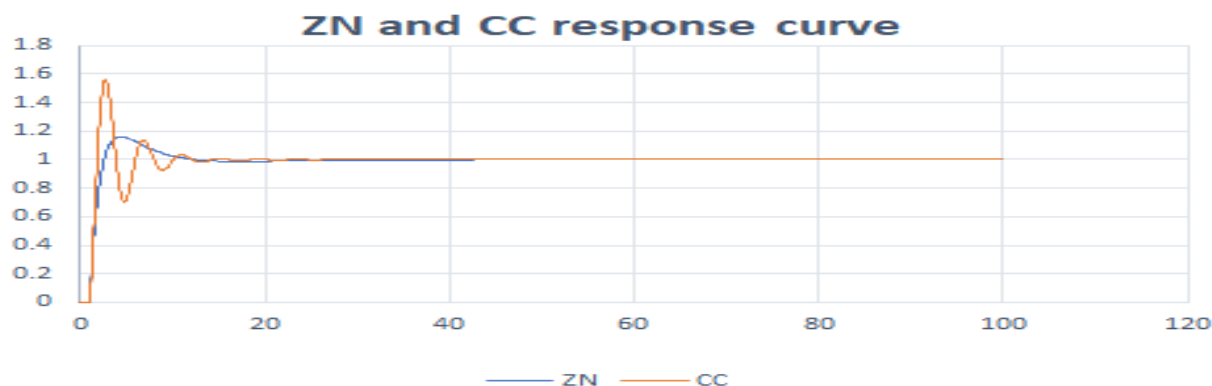

Fig.8.Comparison of ZN-II and CC method.

### GENETIC ALGORITHM PARAMETERS:

Parameter Value	VALUE
Population size	100
Number of generation	10
Crossover Fraction	0.8
Mutation Rate	0.01



ISSN (Print) : 2320 – 3765  
ISSN (Online): 2278 – 8875

# International Journal of Advanced Research in Electrical, Electronics and Instrumentation Engineering

(A High Impact Factor, Monthly, Peer Reviewed Journal)

Website: [www.ijareeie.com](http://www.ijareeie.com)

Vol. 9, Issue 2, February 2020

## PID VALUES OBTAINED FROM GENETIC ALGORITHM:

P	I	D
1.7302	0.3810	0.0205

By analyzing the simulation results of ZN, CC and GA the system becomes stable for the PID values which is obtained from the GA. Since the system shows minimal oscillations and it reaches the steady state within the short duration of time.

## VIII.CONCLUSION

The effect of  $K_p$ ,  $K_i$  and  $K_d$  in PID controller tends to make the closed loop system become **more stable**. Proportional controller ( $K_p$ ) have the effect of **reducing the rise time** but it will never eliminate the steady-state error. An integral control ( $K_i$ ) have the **effect of eliminating the steady-state error**, but it may make the transient response more acute. A derivative control ( $K_d$ ) have the **effect of increasing the stability** of the system, reducing the overshoot and helps in improving the transient response.

## REFERENCES

- [1]. Anjali T & Shyju Susan Mathew, "Implementation of Optimal control for ball and beam system" 2016 International Conference on Emerging Technological Trends [ICETT]
- [2]. B. Ahmad and I. Hussain, "Design and hardware implementation of ball & beam setup," 2017 Fifth International Conference on Aerospace Science & Engineering(ICASE), Islamabad 2017, pp 1-6 doi.
- [3]. C. Osinski, A. L. R. Silveira, C. Stiegelmaier, M. G. Bergamini and G. V. Leandro, "Control of Ball and Beam System Using Fuzzy PID Controller," 2018 13th IEEE International Conference on Industry Applications (INDUSCON), Paulo, Brazil, 2018, pp. 875-880
- [4]. Mohammad Keshmiri, Ali Fellah Jahromi\*, Abolfazl Mohebbi, Mohammad Hadi Amoozgar and Wen-Fang Xie, "Modeling and control of ball and beam system using model based and non-model based control approaches," international journal on smart sensing and intelligent systems, vol. 5, no. 1, march 2017
- [5]. S. Chati and A. Patel, "LabView Implementation of Ball and Beam System Using Cascade PD Control," 2018 2nd International Conference on Electronics, Materials Engineering & Nano-Technology (IEMENTech), Kolkata, 2018, pp 1-5.
- [6]. P.J. Fleming and C.M. Fonseca, "Genetic algorithms in control systems engineering: a brief introduction", IEE Colloquium on Genetic Algorithms for control systems Engineering, London, UK, 1993, pp.1/1-1/5
- [7]. P. V. M. Maalini, G. Prabhakar and S. Selvaperumal, "Modelling and control of ball and beam system using PID controller," 2016 International Conference on Advanced Communication Control and Computing Technologies (ICACCCT), Ramanathapuram, 2016, pp. 322-326A
- [8]. Aziz, N. S. A., Adnan, R., & Tajjudin, M. (2017). "Design and evaluation of fuzzy PID controller for ball and beam system", 2017 IEEE 8th Control and System Graduate Research Colloquium (ICSGRC).
- [9]. Valluru, S. K., Singh, M., & Singh, S. (2016). "Prototype design and analysis of controllers for one dimensional ball and beam system", 2016 IEEE 1st International Conference on Power Electronics, Intelligent Control and Energy Systems (ICPEICES).
- [10]. Marra, M. A., Boling, B. E., & Walcott, B. L. (n.d.). "Genetic control of a ball-beam system", Proceeding of the 1996 IEEE International Conference on Control Applications IEEE International Conference on Control Applications Held Together with IEEE International Symposium on Intelligent Control IEEE International Symposium on Computer-Aided Control.
- [11]. Chen, W., Sui, X., & Xing, Y. (2012). "Modeling and modulation of nonlinear ball-beam system controller based on matlab", 2012 9th International Conference on Fuzzy Systems and Knowledge Discovery.
- [12]. Rana, M. A., Usman, Z., & Shareef, Z. (2011). "Automatic control of ball and beam system using Particle Swarm Optimization", 2011 IEEE 12th International Symposium on Computational Intelligence and Informatics (CINTI).