



# Fuzzy Controlled Realtime Implementation Of UPC With Facts Controllers

G Sathish Goud<sup>1</sup>, Shankar Moguthala<sup>2</sup>

Assistant Professor, Dept. of EEE, Siddhartha Institute of Engineering and Technology, Ibrahimpatnam, Telangana<sup>1,2</sup>

**ABSTRACT:** To improve the performance of boost converter we are using some techniques that can be implemented by real time implementation of unity power factor correction converter based on fuzzy logic. A single phase AC-DC Boost converter is realized to replace the conventional diode bridge rectifier where DC link voltage is widely used in industrial and domestic applications, it use DC voltage via diode rectifier. Fuzzy controller is used to DC voltage loop circuit to get better performance where a simple diode rectifier has a high distortions in input current wave forms and low power factor to avoid this type of problems, A single phase power factor correction techniques are implemented by using these techniques we can get the power factor near to the unity and small distortions in input current wave forms can be corrected and also we can control the DC voltage. By using PID conventional regulator we can also control the voltage loop of the boost converter. Fuzzy logic is used for the voltage loop with the conventional hysteresis controller to improve the performance of current loop it has become a successful solution to control the complexity in the process. In hysteresis current control a fixed band is used to maintain the current in a band, by that the current can be controlled.

**KEYWORDS:** Fuzzy logic, Voltage control, Rectifiers, Hysteresis, Robustness, DSPACE 1103

## I. INTRODUCTION

DC-link voltage is widely used in industrials and domestic's application, DC voltage is required in variable speed drives and almost of domestic electrical equipment's, it use dc voltage via diode rectifier. Generally, simple diode rectifiers bridges are used to create dc voltage link, because it is simple, cheap and robust. However, the large utilization of diode rectifiers with the rise of the big need of dc voltage in lot of applications exacerbates the problems related to the harmonic pollution in the electrical distribution systems. Many techniques are proposed as solutions against these problems, single phase power factor correction techniques based on active wave determination of the line current is one of them. Their main advantages are:

- Small Distortion input currents wave form.
- Power factor near to unity.
- Controlling the output DC voltage.

## II. BLOCK DIAGRAM

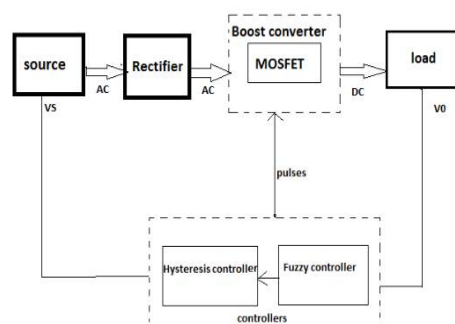

Fig 2.1: block diagram representation



# International Journal of Advanced Research in Electrical, Electronics and Instrumentation Engineering

(A High Impact Factor, Monthly, Peer Reviewed Journal)

Website: [www.ijareeie.com](http://www.ijareeie.com)

Vol. 7, Issue 11, November 2018

To solve this problem, the intelligent controllers have been introduced to get robustness control and performance under parameters variations. Among these controllers logic, artificial neural network are used. This paper presents an analysis and implementation of single phase boost PFC based on fuzzy logic controller, a fuzzy logic controller is used for the voltage loop, with the conventional hysteresis controller to improve the performance of the current loop and it doesn't need a mathematical model of the PFC converter for the controller designs. The proposed controllers have been tested through MATLAB/Simulink and an experimental implementation has been realized with an experimental test bench and the DSPACE DS1103 auto box controller board.

### III. POWER FACTOR CORRECTIONS

Power factor correction Power factor correction is the term given to a technology that has been used since the turn of the 20th century to restore the power factor to as close to unity as is economically viable. This is normally achieved by the addition of capacitors to the electrical network which compensate for the reactive power demand of the inductive load and thus reduce the burden on the supply. There should be no effect on the operation of the equipment. To reduce losses in the distribution system, and to reduce the electricity bill, power factor correction, usually in the form of capacitors, is added to neutralize as much of the magnetizing current as possible. Capacitors contained in most power factor correction equipment draw current that leads the voltage, thus producing a leading power factor.

### IV. HYSTERESIS CURRENT CONTROL

This control technique requires defining upper hysteresis band limit and lower hysteresis band limit. In open loop control strategy, the variation in output DC voltage is common problem if load is variable, but we can get steady output if close loop strategy is used. In close loop control, output current signal is compared with reference current signal which is given. Which decrease the error in output and gives desired output. The generated gate pulses can be controlled by PI or PID controllers. These signals are for power switching devices, when upper and lower limits of hysteresis bands are exceeded. In this technique, the power switching devices will not be switched if any major error is there.

We can use Ziegler-Nichols method for tuning of PID controllers. The conventional method of hysteresis control is known as two-level hysteresis current control technique. It is nonlinear method and it is based on current error. This method consists of a comparison between the load current and band limit given to it. When it crosses the upper band limit, the switches turns off, when current crosses the lower band limit, switches turns on.

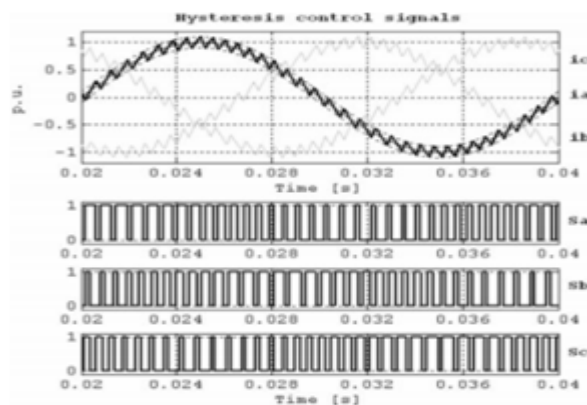

Fig 4.1 The idea and control signals of Hysteresis-Band PWM

The proposed technique is with fixed hysteresis band  $H$  for open loop and variable hysteresis band  $H'$  for closed loop for obtaining the current ripple at output side, a value of hysteresis band must be as small as possible. It will cause very high switching frequency as well as high switching losses. It also required high-end controllers for better performance in practical.

# International Journal of Advanced Research in Electrical, Electronics and Instrumentation Engineering

(A High Impact Factor, Monthly, Peer Reviewed Journal)

Website: [www.ijareeie.com](http://www.ijareeie.com)

Vol. 7, Issue 11, November 2018

## V. MODELLING OF SINGLE PHASE BOOST RECTIFIER

### Current-Loop Controller

The fixed band Hysteresis Current Controller (HCC) is used to maintain the current in a band. When the difference between the measured and the reference current is out of the band, the controller gives a switching command. Figure 2 shows the hysteresis current control principle with fixed band. The input of the HCC is the current error and the output is the control command of the switch. This HCC control technique is a nonlinear control. It has the advantages of robustness and implementation simplicity. It has a fast response time, stability and satisfactory accuracy. This command has only one control parameter; it is the hysteresis band width. The current in the PFC circuit oscillates around a constant band hysteresis as shown in Fig.3. The inductor current in the output of the diode bridge is controlled using a hysteresis regulator. The comparator determines the control command of the boost converter switch associated with the bridge. The switching times

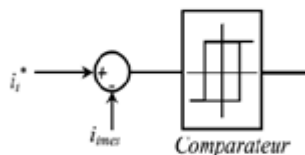

Fig 5.1 Hysteresis Current Control

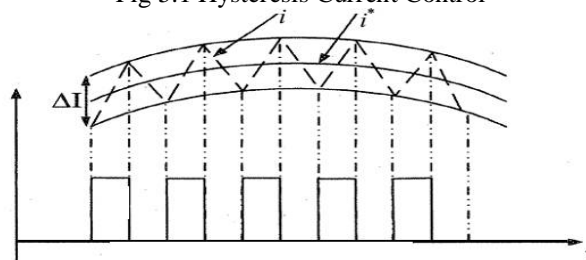

Fig5.2: Hysteresis Current Control

The main drawback of HCC controller is the variable and uncontrollable switching frequency, and the switching losses are unknown.

### 5.1 Fuzzy Logic-Based Dc Bus Voltage Controller

The aim of the dc voltage loop controller is to maintain this voltage around a constant reference value by controlling the charge and discharge of the capacitor. The main causes of the variation in capacitor voltage are the switching losses in the converter and the variation of the load between the outputs of the converter. To regulate this voltage we adjust the value of the reference current, it is intended to compensate any variation of the energy stored in the capacitor. In this paper, the conventional proportional integral controller has been replaced by the fuzzy logic controller; it is used to control the output dc voltage of the boost converter. The principle of fuzzy logic is inspired from human in the sense that the variables used are not logical variables (within the meaning of binary logic) but linguistic variables, close to the current human language. In addition, these linguistic variables are processed using rules that mention to certain knowledge of the system behavior.

The proposed fuzzy logic control for the PFC rectifier is shown in Fig. 4. The obtained error  $e(k) = v_{0ref}(k) - v_0(k)$  and its variation  $\Delta e(k) = e(k) - e(k-1)$  at the  $k$ th sampling instant are used as inputs of fuzzy controller. The output of the fuzzy system is the variation amplitude of reference current  $\Delta I^*$ . The dc bus voltage is controlled by adjusting the amplitude of reference current  $I^*$  Where  $G_e$  and  $G_{de}$  are constants used to normalize the error and the error variation.

# International Journal of Advanced Research in Electrical, Electronics and Instrumentation Engineering

(A High Impact Factor, Monthly, Peer Reviewed Journal)

Website: [www.ijareeie.com](http://www.ijareeie.com)

Vol. 7, Issue 11, November 2018

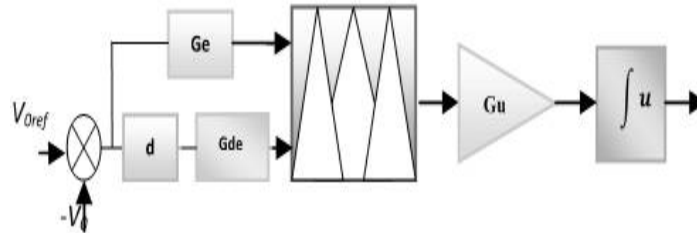

Fig.5.3: Fuzzy logic controller for DC bus

TABLE I. CONTROL RULE TABLE OF THE FLC

	NG	ZE	PG
NG	NG	NG	ZE
ZE	NG	ZE	PG
PG	ZE	PG	PG

Table 5.4: implementation of rules

## VI. SIMILATION RESULTS

To show the effectiveness of fuzzy control based power factor correction boost converter, mathematical simulation has been developed by using MATLAB/Simulink. The reference output voltage is taken as 100V. In order to examine the robustness of the fuzzy logic controller, an experimental test using the dSPACE 1103 controller board.

These results confirm the importance of PFC for the conservation of energy in the power converters. Show the simulation of the line current and its harmonic spectrum and the dc-bus voltage, depict the experimental line voltage and line current for the Fuzzy controlled PFC with fixed band hysteresis current controller. From these figures, it can be seen that the obtained results with the proposed FLC controller are efficient and better than the international norms. Line current is almost sinusoidal and in phase with the grid voltage, the THD is less than 3%. Experimental dc bus voltage response, the output voltage reached to the new value after 500ms.

TABLE II. PARAMETERS OF SIMULATION

Parameters	Value
DC bus voltage	100V
Line inductance	2 mH
PFC inductance	7mH
DC link capacitor	4700µF
Load resistance	60•
Sampling time	2e-5 s

Table 6.1 parameter of simulation

# International Journal of Advanced Research in Electrical, Electronics and Instrumentation Engineering

(A High Impact Factor, Monthly, Peer Reviewed Journal)

Website: [www.ijareeie.com](http://www.ijareeie.com)

Vol. 7, Issue 11, November 2018

## 6.1 EXECUTED RESULT

### 6.1.1 Designed Circuit

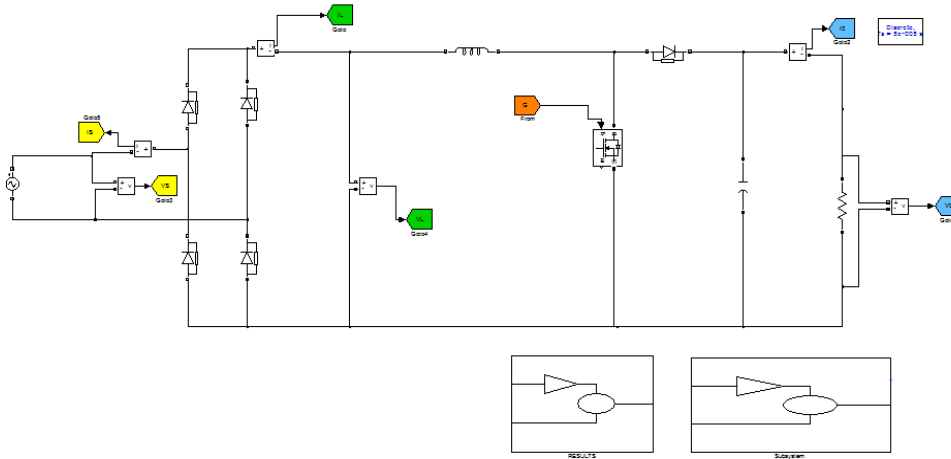

### 6.1.2 Sub System Circuit

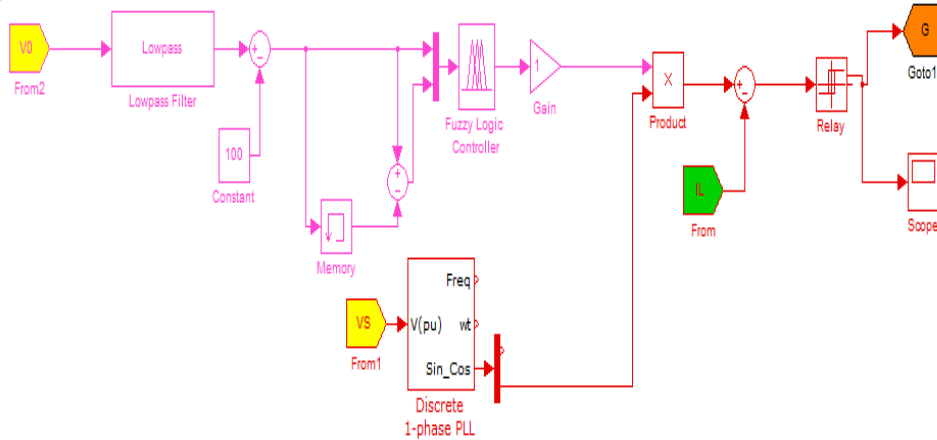

## Output Results

We have provide the input current for Diode the power factor can be controlled to PLL the diode current waveform is shown in fig

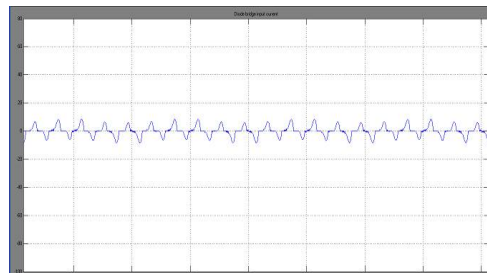

Fig 6.2.1: Diode Bridge Input Current

We have provide the input voltage for Diode the power factor can be controlled to fuzzy logic to the diode voltage waveform is shown in fig



# International Journal of Advanced Research in Electrical, Electronics and Instrumentation Engineering

(A High Impact Factor, Monthly, Peer Reviewed Journal)

Website: [www.ijareeie.com](http://www.ijareeie.com)

Vol. 7, Issue 11, November 2018

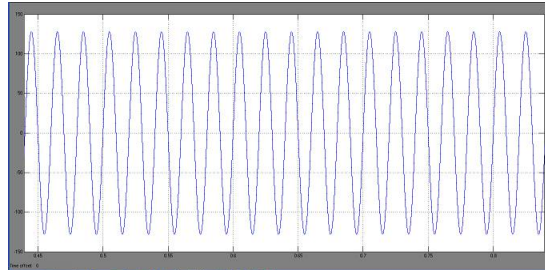

Fig 6.2.2: Diode Bridge Input Voltage

We have provide the Dc bus current to fuzzy controller the power factor can be controlled to fuzzy logic to the Dc current waveform is shown in fig

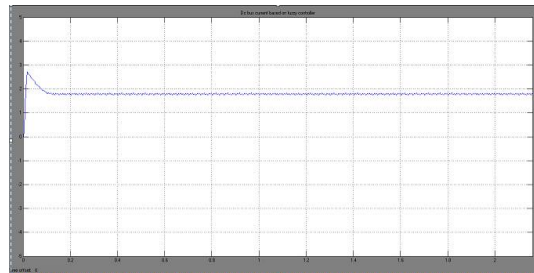

Fig 6.2.3: Dc Bus Current Based On Fuzzy Controller

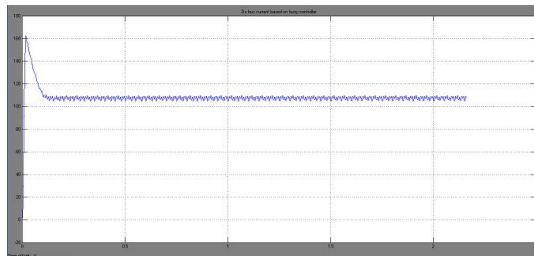

Fig 6.2.4: Dc bus current based on fuzzy logic controller

## VII. CONCLUSION

In this paper, a single-phase PFC converter DC voltage loop has been analyzed. The fuzzy logic controller technique is implemented to improve the performance of the PFC converter, it is robust and efficient. Matlab/Simulink has been used to simulate the proposed techniques with successful result, the dSPACE 1103 have been used to implement the fuzzy controller in real-time. Simulation results have been presented and confirmed by the real time tests; in the same time, high efficiency is obtained. The proposed controller applied to the unity power factor give better results, a reduced total harmonic distortion, and robustness control during parameter variations.

## REFERENCES

- [1] M. Malinowski, M. Jasinski, M.P. Kazmierkowski, "Simple direct power control of three-phase PWM rectifier using space-vector modulation (DPC SVM)", IEEE Transactions on Industrial Electronics (2004) 447–454
- [2] Kessal A, Rahmani L, Gaubert JP, Mostefai M. "Analysis and design of anisolated single-phase power factor corrector with a fast regulation". ElectrPower Syst Res 2011; 81:1825–31. [3]. Guo L, Hung JY, Nelms RM. "Comparative evaluation of sliding mode fuzzy controller and PID controller for a boost converter." Electr Power SystRes 2011; 81:99–106.
- [4]. Kessal A, Rahmani L, Gaubert JP, Mostefai M. "Experimental design of a fuzzy controller for improving power factor of boost rectifier". Int J Electron2012;99 (12):1611–21.
- [5]. Chung HSH, Tam EPW, Hui SYR. "Development of a fuzzy logic controller for boost rectifier with active power factor correction", In: IEEE Power Electronics Specialists Conference PESC'99, 1; 1999. p. 149–54.





ISSN (Print) : 2320 – 3765  
ISSN (Online): 2278 – 8875

# International Journal of Advanced Research in Electrical, Electronics and Instrumentation Engineering

(A High Impact Factor, Monthly, Peer Reviewed Journal)

Website: [www.ijareeie.com](http://www.ijareeie.com)

Vol. 7, Issue 11, November 2018

[6]. Sagiroglu S, Colak I, Bayindir R. "Power factor correction technique based on artificial neural networks", Energy Convers Manag 2006; 47:3204–15.

[7] Kessal A, Rahmani L, Gaubert JP, Mostefai M. "Experimental design of a fuzzy controller for improving power factor of boost rectifier". Int J Electron 2012;99 (12):1611–21.

## BIOGRAPHY



**G. Sathish Goud**, has Received his B.Tech degree in Electrical and Electronics Engineering from JNTUH, Hyderabad, India and M.Tech degree in electrical power systems from JNTU Hyderabad, India. He is life member of **Indian Society for Technical Education**. Presently He is working as Assistant Professor In Siddhartha Institute of Engineering & Technology, Hyderabad. His is doing currently research in Fuzzy logic controllers, ANN and electrical power systems, power electronic drive



**Shankar Moguthala**, Received M.Tech degree in Electrical & Power Engineering from JNTU Hyderabad. Presently He is working as Assistant Professor In Siddhartha Institute of Engineering & Technology, Hyderabad. He is life member of **Indian Society for Technical Education**, Life Member of **IAENG** at present he is working in area of Machines, Power Systems Power Quality, FACTS and Neural Networks & fuzzy logic.