



ISSN (Print) : 2320 – 3765  
ISSN (Online): 2278 – 8875

## International Journal of Advanced Research in Electrical, Electronics and Instrumentation Engineering

(A High Impact Factor, Monthly, Peer Reviewed Journal)

Website: [www.ijareeie.com](http://www.ijareeie.com)

Vol. 7, Issue 3, March 2018

# Oxygen Gas Monitoring System in Intelligent Food Packaging Using a Passive RFID Tag Combined with an Oxygen Indicator

Hana Lee<sup>1</sup>, Jinsu Han<sup>2</sup>, Keehoon Won<sup>1</sup>, Kihwan Eom<sup>2</sup>

Professor and Student, Department of Chemical and Biochemical Engineering, Dongguk University-Seoul  
30 Pildong-ro 1-gil, Jung-gu, Seoul 04620, Republic of Korea<sup>1</sup>

Professor and Student, Department of Electronics and Electrical Engineering, Dongguk University-Seoul  
30 Pildong-ro 1-gil, Jung-gu, Seoul 04620, Republic of Korea<sup>2</sup>

**ABSTRACT:** Oxygen can cause biochemical and microbial spoilage of foods in packages. For this reason it is important to monitor oxygen concentrations in intelligent food packaging. This study proposes the monitoring of oxygen levels through the use of a passive RFID tag integrated with an electrochemical sensor-type oxygen indicator. This monitoring system combines the following components: a self-powered colorimetric oxygen indicator, a UHF band RFID tag, an interface circuit, a reader, and a server. The storage capacitor of the passive type interface circuit can be used as an auxiliary power source for the passive RFID tag. This system enables the online monitoring of oxygen concentrations by the naked eye at a short distance and by the tag at a long distance. To demonstrate the performance of this system, the concentration of oxygen gas in a plastic package containing oxygen scavengers is monitored over time qualitatively and quantitatively. Additionally, it is shown that employing the storage capacitor allows the recognition distance to be increased.

**KEYWORDS:** Oxygen concentration monitoring system, Passive UHF band RFID tag, Oxygen indicator, Storage capacitor, Intelligent food packaging.

### I. INTRODUCTION

In recent years consumers have become more interested in the quality and safety of food, and so they are demanding more information about them. Intelligent food packaging can provide consumers with reliable and accurate information about the quality and safety of food by monitoring the condition of packaged foods or the surrounding environment [1-4]. It can be achieved by three main components: (1) indicators, which aim to provide qualitative information about food quality through color changes; (2) sensors, which allow for the rapid and definite quantification of conditions inside food packages; and (3) data carriers such as barcodes and radio-frequency identification (RFID) tags, which are specifically intended for the purpose of storage, distribution, and traceability. RFID technology is being developed to facilitate networking, intelligent product management and distribution while ensuring security, safety, and environmental considerations. Recently, great attention is being focused on smart RFID tags which combine sensors and RFID tags [5-8].

Various properties related to the quality and safeties of packaged foods (e.g., temperature, and the concentrations of oxygen, carbon dioxide, and volatile amines) have been monitored using visual indicators and smart RFID tags [9-13]. It is necessary to monitor using smart RFID tags with colorimetric indicators, which enable consumers to check the quality and safety of food through visual inspection and also transmit this information together with additional data

# International Journal of Advanced Research in Electrical, Electronics and Instrumentation Engineering

(A High Impact Factor, Monthly, Peer Reviewed Journal)

Website: [www.ijareeie.com](http://www.ijareeie.com)

Vol. 7, Issue 3, March 2018

such as details of the food and manufacturer. Due to these benefits the use of smart RFID tags integrated with visual indicators is an important development in the field of intelligent food packaging [13–16].

This study reports the features and performance of an oxygen gas monitoring system using a passive RFID tag integrated with a colorimetric oxygen indicator. Oxygen is one of the most significant parameters in food packaging because it is involved in the biochemical and microbial spoilage of foods. The proposed system consists of an electrochemical sensor-type oxygen indicator, a UHF band RFID tag, an interface circuit, a reader, and a server. This online monitoring system can display oxygen concentrations using quantitative values as well as qualitative outputs with four levels: very high, high, medium, and low. In order to evaluate the performance of this system, the oxygen gas concentration in a plastic packaging containing oxygen scavengers has been monitored online.

## II. CONSTRUCTION OF OXYGEN CONCENTRATION MONITORING SYSTEM

The proposed system consists of a colorimetric oxygen indicator, a UHF band RFID tag, an interface circuit, a reader, and a server. Information from the oxygen indicator inside a food package is read by the Speedway Revolution UHF RFID Reader. The oxygen gas concentration can be confirmed by the naked eye at short distances and by the tag at long distances. Four levels of the oxygen concentration (very high, high, medium, and low) can be reported to a server computer through MFC (Microsoft Foundation Class) software. An overview of the monitoring system is shown in Figure 1.

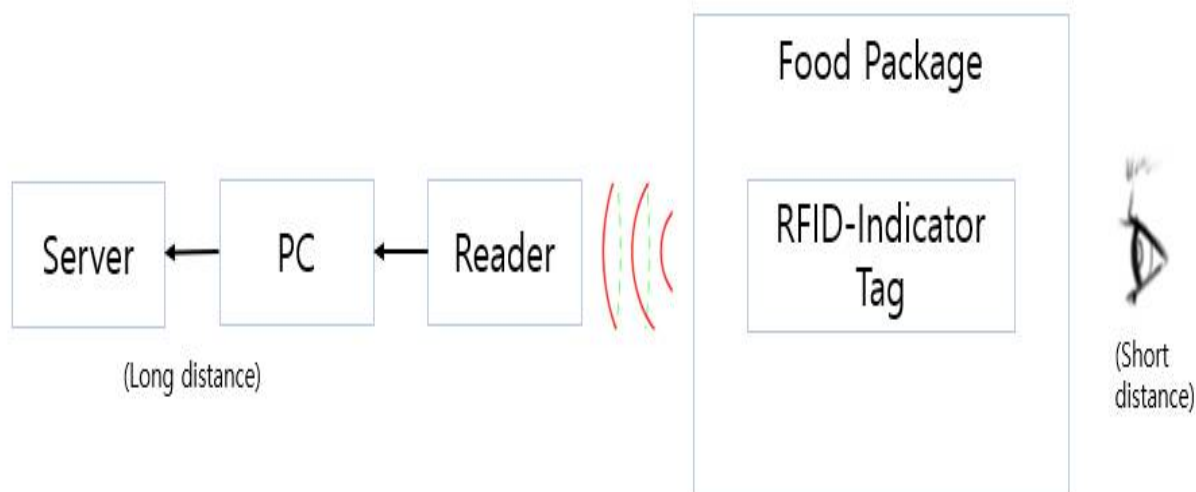

Fig. 1 Schematic diagram of the oxygen monitoring system

## III. THE RFID TAG COMBINED WITH AN OXYGEN INDICATOR

For this system (the integration of a visual oxygen indicator and an RFID tag), we developed an electrochemical sensor-type oxygen indicator, which changes colors and also generates electrical signals proportional to the oxygen concentration. Moreover, this colorimetric oxygen indicator does not require an external power source. Briefly, this indicator consists of zinc foil, carbon paper, and methylene blue (MB) in an electrolyte solution. Blue MB is reduced to colorless leuco-MB with a concomitant oxidation of zinc, which generates power like a battery. Because oxygen re-oxidizes leuco-MB to MB spontaneously, its concentration determines the power and color [4, 13, 15]. Figure 2 shows the manufactured self-powered colorimetric oxygen indicator.

# International Journal of Advanced Research in Electrical, Electronics and Instrumentation Engineering

(A High Impact Factor, Monthly, Peer Reviewed Journal)

Website: [www.ijareeie.com](http://www.ijareeie.com)

Vol. 7, Issue 3, March 2018

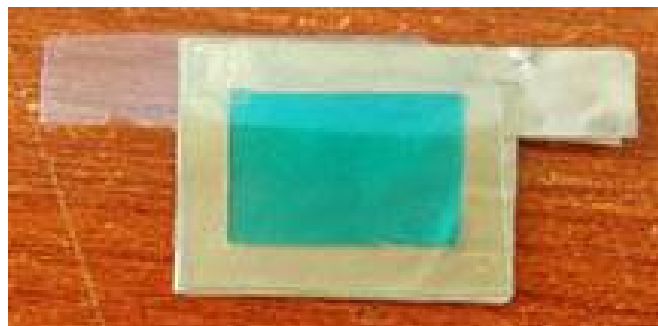

Fig. 2 Photograph of manufactured a colorimetric oxygen indicator

The self-powered colorimetric oxygen indicator was evaluated in a potentiostatic mode using a multi-channel potentiostat/galvanostat (PARSTAT MC, Princeton Applied Research, USA). The indicator was exposed to various oxygen concentrations under conditions where it was continuously supplied with a gas mixture of O<sub>2</sub> and N<sub>2</sub> (0, 5, 10, 15, and 21% oxygen) produced using an automatic gas mixing system (SehwaHightech Co., Korea). The sensor potential was increased from zero to an open circuit voltage at a scan rate of 0.1 mV/s, and both voltages and current densities were recorded. The voltages at a constant current density of 11 μA/cm<sup>2</sup> were plotted against the oxygen gas concentrations as shown in Figure 2(a), which gave a straight line (R<sup>2</sup> = 0.998) correlation in Equation (1):

$$\text{Oxygen Concentration (\%)} = 0.0329 \times \text{Voltage (mV)} \quad (1)$$

The different colors given by the oxygen sensor were also measured using a portable spectrophotometer (CM-2600d, Konica Minolta, Japan) operated in the SCE (specular component excluded) mode. The SCE mode evaluates color in the same way observers would see the color of an object. The colors were expressed in the L\*a\*b\* color space (also referred to as CIELAB), which is the most widely used due to the uniform distribution of colours [12]. In this space L\* refers to lightness with values ranging from 0 (the darkest black) to 100 (the brightest white), while a\* and b\* are the chromaticity coordinates that indicate the specific colour on two axes: +a\* indicates a red colour and -a\* indicates a green colour; +b\* indicates a yellow color and -b\* indicates a blue color. As a result of the MB dye losing its blue color through electrochemical reduction in the absence of oxygen and regaining its blue color in the presence of oxygen, the main color change causes a significant change in the b\* axis, which can be expressed as Δb\*:

$$\Delta b^* = b_R^* - b_O^* \quad (2)$$

where the b\* values of the oxygen sensor are b<sub>R</sub>\* in the absence of oxygen and b<sub>O</sub>\* in the presence of oxygen. The bluer color the colorimetric oxygen sensor displays, the higher the value of Δb\* will be. Two hours after the colorimetric oxygen sensor was exposed to the different oxygen concentrations, the resulting Δb\* values are shown in Figure 3(b). The oxygen sensor exhibited a bluer color with increasing oxygen concentration up to 15%. Figure 3(a) and (b) demonstrate that the oxygen sensor functions as both a colorimetric and electrochemical sensor.

# International Journal of Advanced Research in Electrical, Electronics and Instrumentation Engineering

(A High Impact Factor, Monthly, Peer Reviewed Journal)

Website: [www.ijareeie.com](http://www.ijareeie.com)

Vol. 7, Issue 3, March 2018

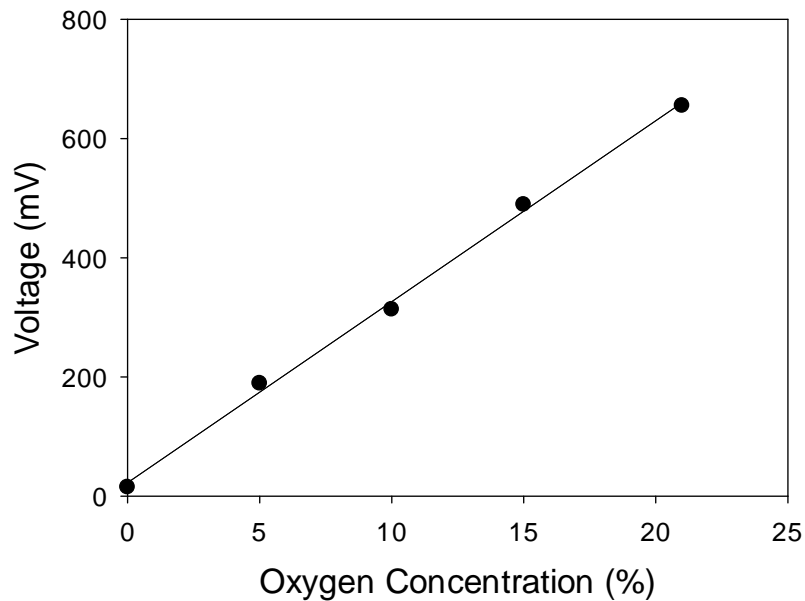

(a)

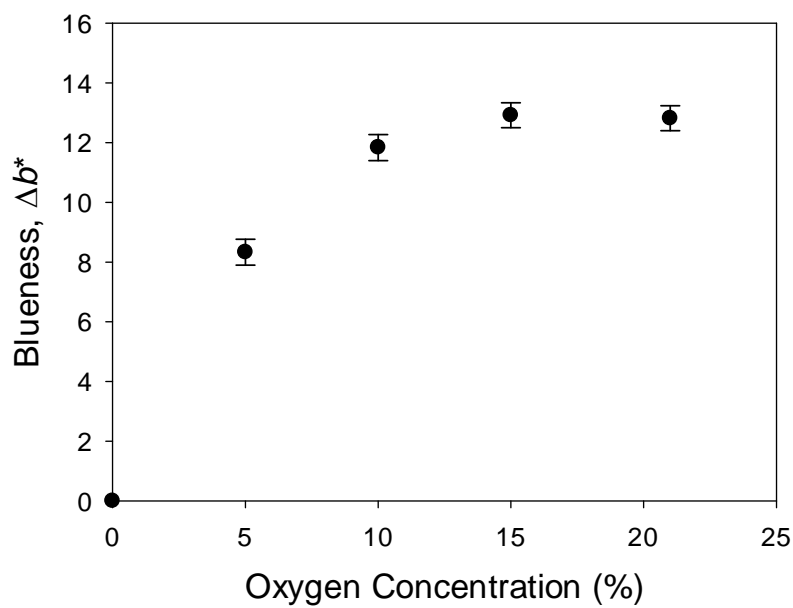

(b)

Fig. 3 Dependence of (a) the voltage and (b) the color of the sensor on oxygen concentration at 25°C

# International Journal of Advanced Research in Electrical, Electronics and Instrumentation Engineering

(A High Impact Factor, Monthly, Peer Reviewed Journal)

Website: [www.ijareeie.com](http://www.ijareeie.com)

Vol. 7, Issue 3, March 2018

The level of the oxygen concentration is determined based on the colour of the sensor-type oxygen indicator, and can be expressed as one of four levels: Very high, High, Medium, and Low. Table 1 describes each of the levels based on experimental data (Figure 3(b)).

TABLE.1 Description of each oxygen level.

Status (%)	O <sub>2</sub> Concentration	O <sub>2</sub> Sensor Voltage (mV)	O <sub>2</sub> Sensor Color
Very High	15<	460<	Blue
High	10 ~ 15	305 ~ 460	Light blue
Medium	5 ~ 10	155 ~ 305	Pale blue
Low	< 5	<155	Colorless

Figure 4 is a block diagram describing the passive type UHF band RFID tag, and Figure 5 is the manufactured passive type UHF band RFID tag [9-11].

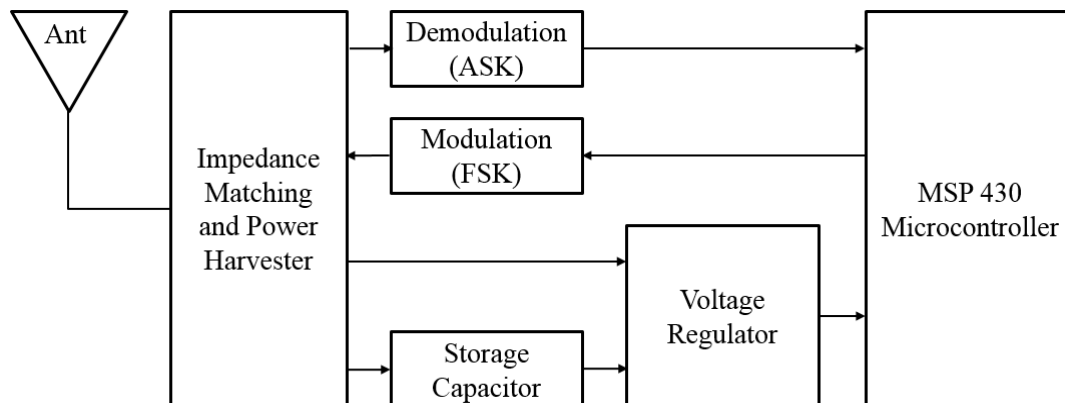

Fig. 4 Block diagram of the passive type UHF band RFID tag



Fig. 5 Photograph of manufactured a passive type UHF band RFID tag

This passive type UHF band RFID tag consists of a UHF band antenna, an impedance matching and power harvester, a demodulator, a modulator, a voltage regulator, a storage capacitor, and a microcontroller (MSP 430). The power harvester rectifies incoming RF energy into DC voltage to charge the storage capacitor and supplies power to MSP 430. The demodulator transmits converted RF data to the microcontroller using the ASK (Amplitude-Shift Keying) method. Finally, the modulator transmits a digital signal from the microcontroller to a reader using the FSK (Frequency-Shift

## International Journal of Advanced Research in Electrical, Electronics and Instrumentation Engineering

(A High Impact Factor, Monthly, Peer Reviewed Journal)

Website: [www.ijareeie.com](http://www.ijareeie.com)

Vol. 7, Issue 3, March 2018

Keying) and backscatter method [2, 3]. The RFID reader used in this oxygen monitoring system is the Speedway Revolution UHF RFID Reader made by Impinj [19].

There is a passive type interface circuit between the self-powered colorimetric oxygen indicator and the RFID tag, and it consists of a low pass filter and a storage capacitor. Its storage capacitor can be used as an auxiliary power source for the passive RFID tag, and Figure 6 is a block diagram of the interface circuit. The RFID tag combined with an oxygen indicator is manufactured in plastic, and Figure 7 is the photograph of this [17-18].

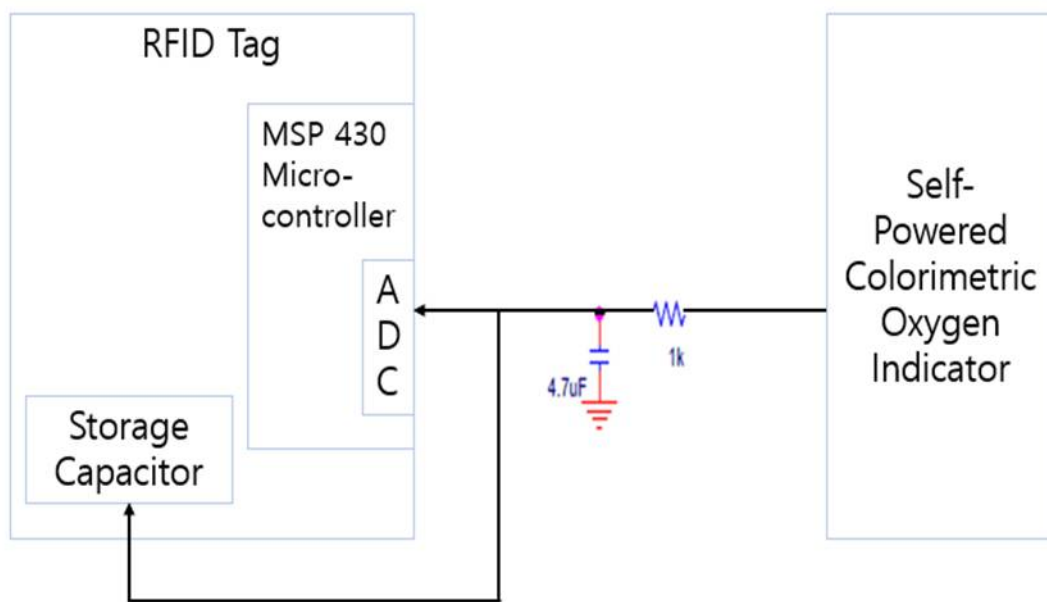

Fig. 6 Interface circuit

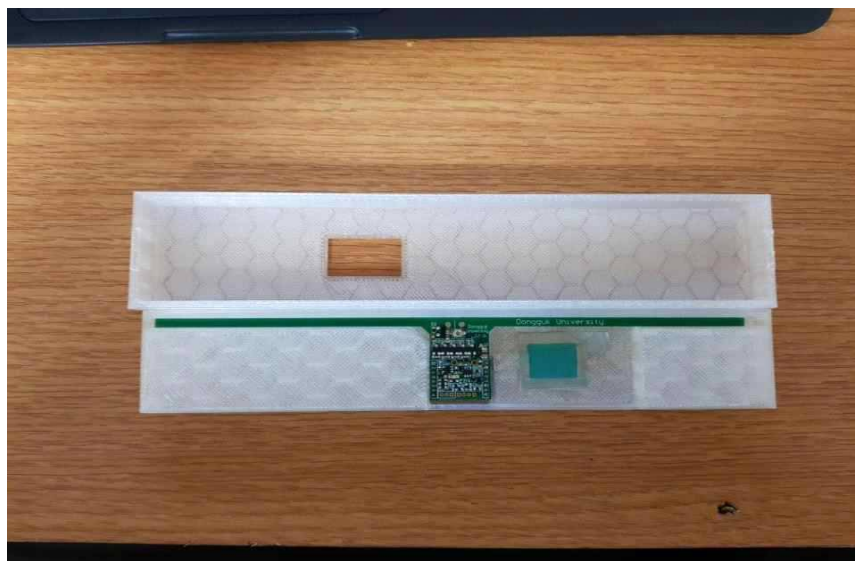

Fig. 7 Photograph of manufactured a RFID tag combined with a colorimetric oxygen indicator



# International Journal of Advanced Research in Electrical, Electronics and Instrumentation Engineering

(A High Impact Factor, Monthly, Peer Reviewed Journal)

Website: [www.ijareeie.com](http://www.ijareeie.com)

Vol. 7, Issue 3, March 2018

## IV. OXYGEN CONCENTRATION MONITORING SYSTEM

The project organization of the Impinj reader includes three levels of hierarchy, at the top level is the MainFrame GUI, at the bottom level is the LLRP/Ethernet code, and in the middle is a wrapper for the LLRP code called RFID reader. This class supports [20]:

- Connecting/disconnecting from the reader via *Connect(string ipAddress)* and *Disconnect()*
- Starting and stopping inventory mode via *StartInventory()* and *StopInventory()*
- Reading available reader settings via *getReaderConfig()*
- Writing reader settings via *readerconfig.setReaderConfig(ReaderConfigconfig)*

Data received from the RFID reader is stored in a server. This server then determines the level of an oxygen concentration (very high, high, medium or low) using the data received from the RFID reader and displays this result on the monitor screen. The flow chart of this oxygen monitoring system for use in food packaging is shown in Figure 8.

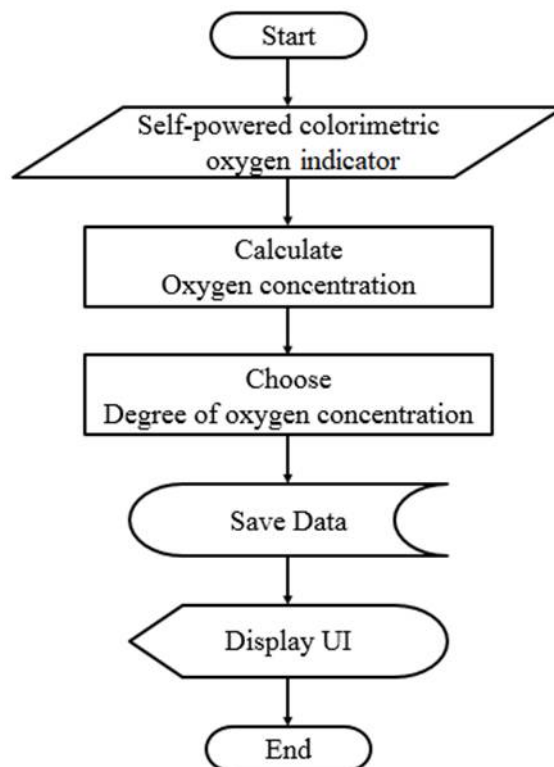

Fig. 8 Flow chart describing operation of the oxygen concentration monitoring system

Figure 9 shows the main interface of the software used in the present study. In this figure, Box A presents the four levels/grades, Box B shows the data received from the tag including the oxygen concentration, and Box C displays previous data [13-14].

# International Journal of Advanced Research in Electrical, Electronics and Instrumentation Engineering

(A High Impact Factor, Monthly, Peer Reviewed Journal)

Website: [www.ijareeie.com](http://www.ijareeie.com)

Vol. 7, Issue 3, March 2018

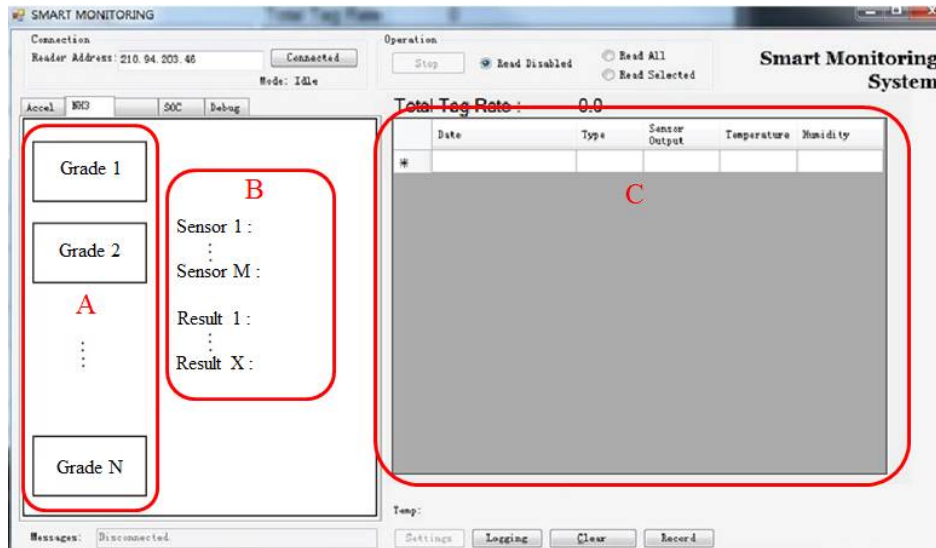

Fig. 9 Monitoring screen

## V. RESULT AND DISCUSSION

For the oxygen concentration monitoring experiments 20 oxygen scavengers were placed in a plastic package as shown in Figure 10, which is a photograph of the device. The first experiments were conducted to determine the recognition distance when the interface circuit is configured using only the low pass filter circuit. These experiments were carried out at a temperature of 25°C, a humidity of 30%, and 30 times. Table 2 shows the maximum recognition distances were 2.9 meters.

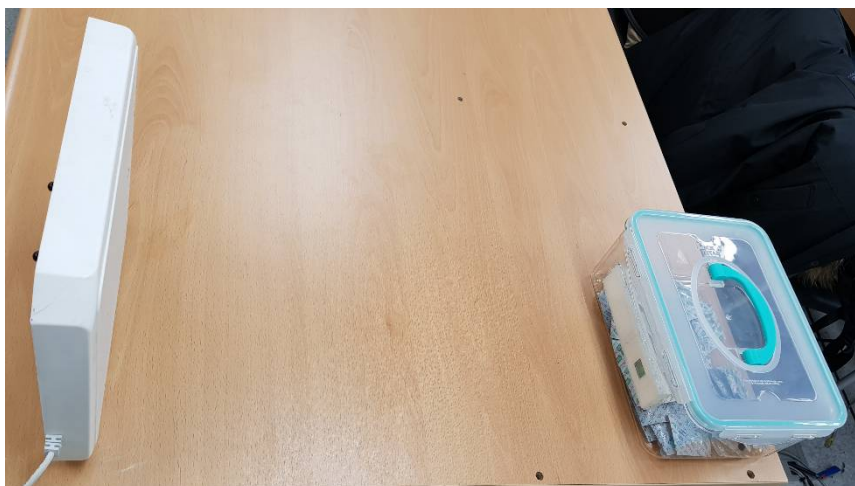

Fig. 10 Photograph of the experimental device





## International Journal of Advanced Research in Electrical, Electronics and Instrumentation Engineering

(A High Impact Factor, Monthly, Peer Reviewed Journal)

Website: [www.ijareeie.com](http://www.ijareeie.com)

Vol. 7, Issue 3, March 2018

TABLE2. Recognition distance of the monitoring system without using a storage capacitor.

Plastic Packaging	
Distance (m)	Success rate
<2.9	100%
3.5	85%
4.1	75%

A second set of experiments were carried out with the interface circuit configured as the filter and the storage capacitor under the same experimental conditions mentioned above. The results from this second set of experiments are given in Table 3, which indicates that the maximum recognition distances were 2.97 meters. This shows that the storage capacitor increased the recognition distance

TABLE3. Recognition distance of the monitoring system using a storage capacitor.

Plastic Packaging	
Distance (m)	Success rate
<2.97	100%
3.57	85%
4.17	75%

Next, to monitor oxygen concentrations oxygen scavengers were placed in a closed plastic package, which was opened after 27 hours, and then closed again for further 3 hours. During this period (36 hours), the oxygen sensor voltage was measured online every 3 hours. This experiment was carried out at a temperature of 25°C and a humidity of 30% with the distance set at 2 meters. As shown in Figure 11 the voltage decreased gradually to 390 mV during the first 27 hours, implying that the oxygen concentration in the package decreased from 21% to 13%. This decrease in oxygen concentration is caused by the oxygen scavengers in the plastic package. After 27 hours the package was opened, and so the voltage increased again. After re-closing the packaging in the last 3 hours the voltage started to decrease again showing that oxygen was still being consumed by the oxygen scavengers. In addition to these voltage readings the oxygen sensor also displayed color changes. The behaviour shown in Figure 11 clearly proves the integrated system functioned well as an oxygen gas monitoring system, and Figure 12 shows the monitoring screen with the oxygen gas concentration in the package after 18 hours.

# International Journal of Advanced Research in Electrical, Electronics and Instrumentation Engineering

(A High Impact Factor, Monthly, Peer Reviewed Journal)

Website: [www.ijareeie.com](http://www.ijareeie.com)

Vol. 7, Issue 3, March 2018

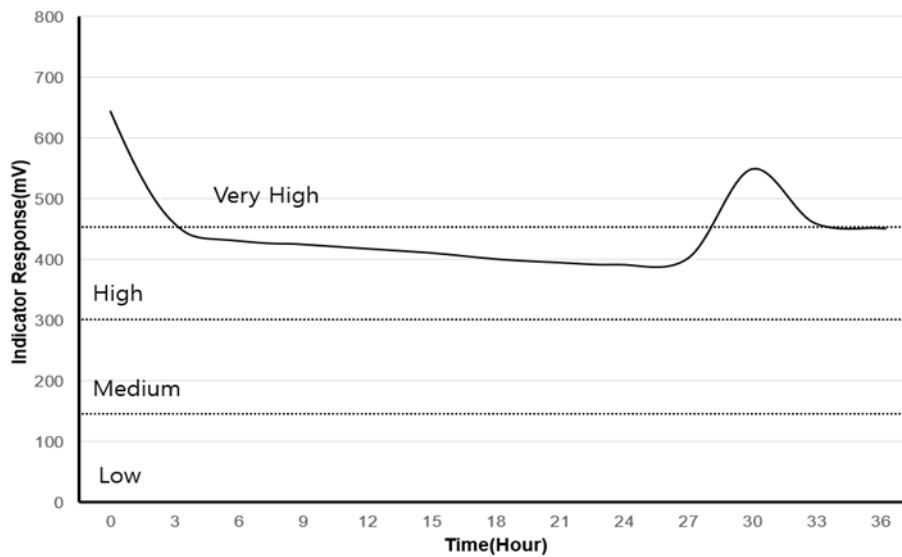

Fig .11 The result of oxygen concentration in a plastic package containing oxygen scavengers

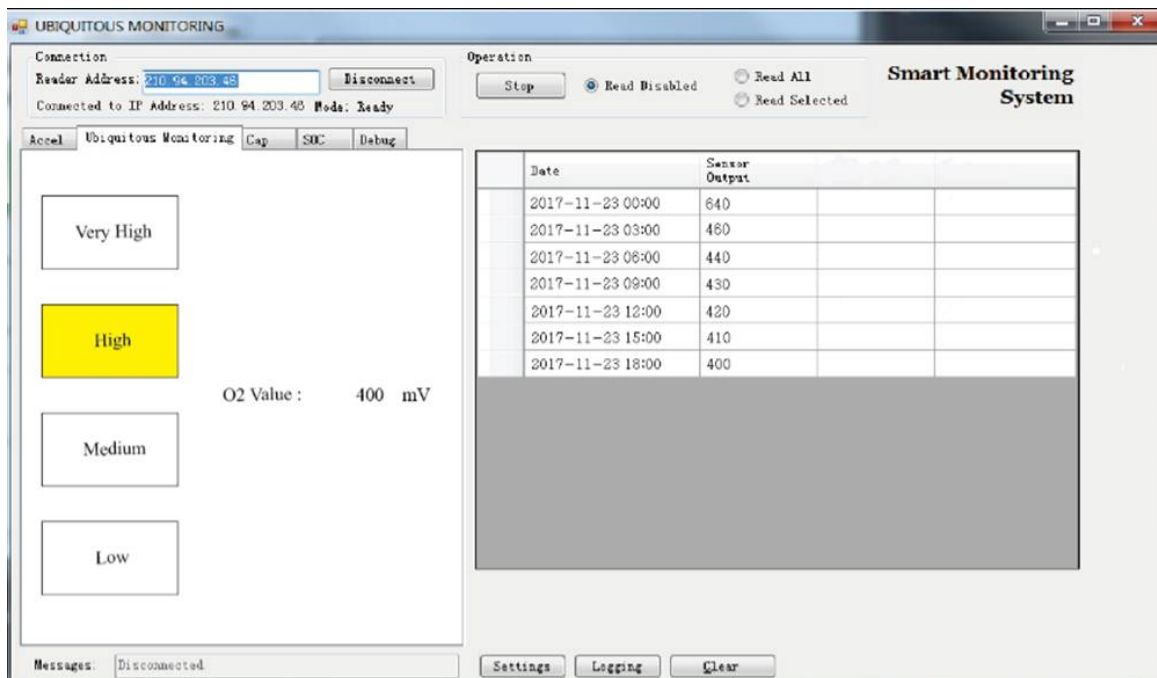

Fig .12 Oxygen monitoring screen



# International Journal of Advanced Research in Electrical, Electronics and Instrumentation Engineering

(A High Impact Factor, Monthly, Peer Reviewed Journal)

Website: [www.ijareeie.com](http://www.ijareeie.com)

Vol. 7, Issue 3, March 2018

## VI.CONCLUSION

In this study oxygen gas concentration levels have been monitored in a food package using a system consisting of a self-powered colorimetric oxygen indicator, a passive UHF band RFID tag, an interface circuit, a reader, and a server. There is a passive type interface circuit between the self-powered colorimetric oxygen indicator and the RFID tag, and it consists of a low pass filter and a storage capacitor. Its storage capacitor can be used as an auxiliary power source for the passive RFID tag. This monitoring system can read oxygen concentrations at four different levels, and each of the levels based on experimental data. To evaluate the usefulness of the proposed monitoring system it was tested using experiments with oxygen concentration changes over time in a plastic packaging containing oxygen scavengers. In a first set of experiments the recognition distance was tested when the equipment is configured using only the low pass filter circuit. For this configuration the maximum recognition distances were 2.9 meters. In a second set of experiments the interface circuit configured as a filter and a storage capacitor was used. For this second configuration the maximum recognition distances were 2.97 meters. Therefore, it can be seen that using a storage capacitor can increase the recognition distance. Third experiment tested the monitoring system with online measurements over a period of time, which demonstrated the functionality of this system. The oxygen concentration can be confirmed by visual inspection at short distances (allowing consumers to see the oxygen content in their food packaging) and by the use of a tag at long distances. This online oxygen monitoring system will be a contribution to the development of intelligent packaging for safer and healthier foods.

## ACKNOWLEDGEMENTS

This research was supported by the agriculture research center program of the ministry of agri-culture, food and rural affairs, republic of Korea (ARC, 710003-03).

## REFERENCES

- [1] K. Won, N. Y. Jang, and J. Jeon, "A Natural Component-Based Oxygen Indicator with In-Pack Activation for Intelligent Food Packaging," *Journal of Agricultural and Food Chemistry*, Vol. 64, pp. 9675–9679, 2016.
- [2] M.Ghaani, C. A. Cozzolino, G. Castelli, and S. Farris, "An Overview of the Intelligent Packaging Technologies in the Food Sector," *Trends in Food Science and Technology*, Vol. 51, pp. 1–11, 2016.
- [3] J. K. Heising, M. Dekker, P. V. Bartels, and M. A. J. S. van Boekel, "Monitoring the Quality of Perishable Foods: Opportunities for Intelligent Packaging," *Critical Reviews in Food Science and Nutrition*, Vol. 54, pp. 645–654, 2014.
- [4] C. H. T. Vu, and K. Won, "Leaching-Resistant Carrageenan-Based Colorimetric Oxygen Indicator Films for Intelligent Food Packaging," *Journal of Agricultural and Food Chemistry*, Vol. 62, pp. 7263–7267, 2014.
- [5] C. Costa, F. Antonucci, F. Pallottino, J. Aguzzi, D. Sarriá, P. Menesatti, "A Review on Agri-food Supply Chain Traceability by Means of RFID Technology", *Food and Bioprocess Technology*, vol. 6, issue 2, pp.353-366, 2013.
- [6] T. B. Tang, M. S. Zulkafli, "Electronic Tongue for Fresh Milk Assessment A revisit of using pH as indicator", 2013 IEEE International Conference on Circuits and Systems (ICCS), pp.167-171, 2013.
- [7] H. Lan, X. Chen, Y.P. Wu, "On Food Safety System Construction from The Perspective of Supply Chain", *International Conference on Quality, Reliability, Risk, Maintenance, and Safety Engineering*, 1505-1507, 2012.
- [8] P. Kumar, H. W. Reinitz, J. Simunovic, K. P. Sandeep, and P. D. Franzon, "Overview of RFID Technology and Its Applications in the Food Industry," *Journal of Food Science*, Vol. 74, pp.101–106, 2009.
- [9] N. Pesonen, K. Jaakkola, J. Lamy, K. Nummila, and Marjonen, J, "Smart RFID Tags, Development and Implementation of RFID technology," *Turcu, Vienna*, pp. 159–178, 2009.
- [10] Daniel J., Yeager and Richa P, "Wirelessly-Charged UHF Tags for Sensor Data Collection," *IEEE International Conference on RFID*, pp. 320–327, 2008.
- [11] Alanson P. Sample, Design of an RFID-Based Battery-Free Programmable Sensing Platform. In: *IEEE Transactions on Instrumentation and Measurement*, vol. 57, no. 11, pp. 2608–2615, 2008.
- [12] R. Want, "Enabling ubiquitous sensing with RFID", *Computing*, vol. 37, no.4, pp.84-86, 2004.
- [13] K. Eom, K., W. Lee, J. Shin, H. Lee, and K. Won, "Integration of an Oxygen Indicator Sensor with a Passive UHF band RFID Tag," *Contemporary Engineering Sciences*, Vol. 9, pp. 889–896, 2016.
- [14] K. Eom, K., K. H. Hyun, L. Sen, and J. Kim, "The Meat Freshness Monitoring System Using the Smart RFID System," *International Journal of Distributed Sensor Networks*, Vol. 8, pp. 1–9, 2014.
- [15] A. Martínez-Olmos, J. Fernández-Salmerón, N. Lopez-Ruiz, A. R. Torres, L. F. Capitan-Vallvey, and A. J. Palma, "Screen Printed Flexible Radiofrequency Identification Tag for Oxygen Monitoring," *Analytical Chemistry*, Vol. 85, pp. 11098–11105, 2013.
- [16] D. Wu, and D. W. Sun, "Colour Measurements by Computer Vision for Food Quality Control – A Review," *Trends in Food Science and Technology*, Vol. 29, pp.5–20, 2013.



ISSN (Print) : 2320 – 3765  
ISSN (Online): 2278 – 8875

# International Journal of Advanced Research in Electrical, Electronics and Instrumentation Engineering

*(A High Impact Factor, Monthly, Peer Reviewed Journal)*

Website: [www.ijareeie.com](http://www.ijareeie.com)

**Vol. 7, Issue 3, March 2018**

[17] Finkenzeller, K., Muller, D.” RFID Handbook,”Wiley, 2010.

[18] A. P. Ramon, and G. W. John, “Sensors and Signal Conditioning, 2nded,” John Wiley & Sons, Inc., New York, USA, pp. 397–419, 2001.

[19] Impinj, [http://www.impinj.com/Speedway\\_Revolution\\_UHF\\_RFID\\_Reader.aspx](http://www.impinj.com/Speedway_Revolution_UHF_RFID_Reader.aspx).

[20]WISP,<http://wisp.wikispaces.com/UsingImpinjLLRP>