



ISSN (Print) : 2320 – 3765
ISSN (Online): 2278 – 8875

International Journal of Advanced Research in Electrical, Electronics and Instrumentation Engineering

(A High Impact Factor, Monthly, Peer Reviewed Journal)

Website: www.ijareeie.com

Vol. 7, Issue 2, February 2018

Efficient Controlled Based Wind Energy Conversion System Using PMSG and ANIFIS Adaptive Maximum Power Point Tracking Control Algorithm

Ramachandran.S, Dr.M.Ramasamy, Sathishkumar.S, Kamalakannan.T

Assistant Professor, Department of EEE, Paavai Engineering College, Namakkal, India

Associate Professor, Department of EEE, K.S.R College of Engineering, Namakkal, India

UG Scholar, Dept. of EEE, Paavai Engineering College, Namakkal, India

UG Scholar, Dept. of EEE, Paavai Engineering College, Namakkal, India

ABSTRACT: A maximum power point tracking (MPPT) algorithm for wind energy conversion systems. The proposed algorithm utilizes the dc current as the disturbing variable. The algorithm detects adaptive Maximum Power Point Tracking Control Algorithm sudden wind speed changes indirectly through the dc-link voltage slope. The voltage slope is additionally used to enhance the tracking speed of the algorithm and to avert the generator from stalling under rapid wind speed slowdown conditions. The proposed method uses two modes of operation: A perturb and observe (P&O) mode with adaptive step size under slow wind speed fluctuation conditions, and a prediction mode employed under expeditious wind speed change conditions. The dclink capacitor voltage slope reflects the expedition information of the generator, which is then used to prognosticate the next step size and direction of the current command. The algorithm shows enhanced stability and expeditious tracking capability under both high and low rate of change wind speed conditions.

KEYWORDS: Maximum power point tracking (MPPT), Perturb & observe algorithm (P&O), wind energy conversion system (WECS), Unity power factor, power signal feedback (PSF), DFIG.

I. INTRODUCTION

The growing need for electrical energy and the will to preserve the nature justifies the use of renewable energy sources. The use of renewable sources for electric power generation has been a huge increase since the past decade [1]. Increased economic and ecological woes have driven researchers to discover newer and better means of generating electrical energy. In this race, the production of electricity by wind turbine is actually the best method in comparison with the energy produced by the solar source conversion and this is due to the price per a kilo watt that is less elevated with respect to the second [2]. Among the most used and available technologies for wind turbines, the doubly fed induction generator (DFIG) is the most accepted because it presents greater benefits for a reduced conversion structure operation, and the control four quadrants of active and reactive power. Due to variable speed operation, the total energy production is 30% to 40% higher and therefore capacity utilization factor is improved and the cost per kWh of energy is reduced, wind energy is gaining more support due to its less space occupancy and zero-carbon emission during operation. Variable speed wind energy conversion systems (WECSs) can harness more electrical energy than fixed speed WECSs by controlling their speed according to the variations in wind velocity [3], [4]. Maximum power point tracking (MPPT) algorithms are used to extract maximum power from the available wind energy and they are classified into three categories, namely tip speed ratio (TSR) control, power signal feedback (PSF) control and hill climb search (HCS) control. Across the globe, research community is exploring all possibilities for the efficient energy conversion from freely available abundant renewable energy sources. Among the popular renewable energy sources [5].

II. RELATED WORK

- **Wind energy conversion system modeling**

The wind turbine modeling is inspired. In the following, the wind turbine components models are briefly described. In recent years, wind energy has become one of the most important and promising sources of renewable energy, which demands additional transmission capacity and better means of maintaining system reliability. Wind energy is a nonpolluting, safe renewable source. The evolution of technology related to wind systems industry led to the development of a generation of variable speed wind turbines that present many advantages compared to the fixed speed wind turbines. The power retrieved from wind energy systems depends on the power set point traced by maximum power point tracking.

$$s = (\omega_s - \omega_r) / \omega_s(1)$$

Where,

ω_r is the rotor rotational speed. ω_s is the

$$P_m = \frac{1}{2} C_p d A R^2 v_w^3 \quad (2)$$

Where,

d is the air density (kg/m³),

R is the radius of turbine (m) and v_w is the wind speed in (m/s).

C_p is the power coefficient of the blade which is a nonlinear function of tip-speed ratio

The mechanical power from the wind turbine is affected. It is defined as the ratio of turbine rotor tip speed to the wind speed, the maximum wind turbine efficiency occurs for a given wind speed. To maintain the optimal TSR, turbine's rotor speed is to be changed as the wind speed changes. Also, extracts maximum power from wind. Calculation requires the measured value of wind speed and turbine speed data. Wind speed measurement increases the system cost and also leads to practical difficulties. Optimal values Differ from one system to another.

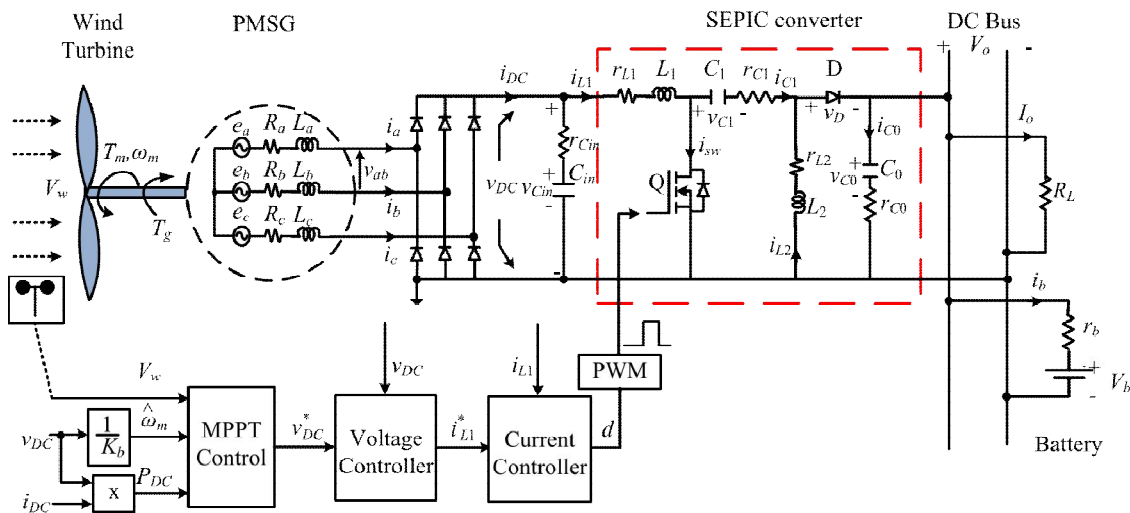

Figure: 1 Wind energy conversion system modeling

Wind power is dominating as one of the potential renewable energy sources in many countries throughout the world. Economically attractive features and environment friendly power production have triggered the proliferation of wind power as a popular clean energy sources over last few decades. In variable-speed wind energy conversion system (WECS), the turbine output power depends on the method of tracking the peak power point and

International Journal of Advanced Research in Electrical, Electronics and Instrumentation Engineering

(A High Impact Factor, Monthly, Peer Reviewed Journal)

Website: www.ijareeie.com

Vol. 7, Issue 2, February 2018

turbine characteristics prompted by the variation in wind speed irrespective of the type of generator used. In fact, the generated turbine power significantly varied by the turbine pitch angle.

III. ADAPTIVE MAXIMUM POWER POINT TRACKING CONTROL ALGORITHM

The proposed control allows the generator to track the optimal operating point of the WECS under fluctuating wind conditions by an efficient two-step tracking process. The first step adapts an intelligent iterative approach to update the duty cycle of the boost converter to coordinate with the rapid changes in the wind conditions. A novel scanning process is initiated in succession with the iterative approach to counteract the non-constant efficiencies of the generator-converter subsystems in order to fine tune the obtained MPP. The performance of the proposed method is verified in simulation and experimental results from a hardware prototype are also presented.

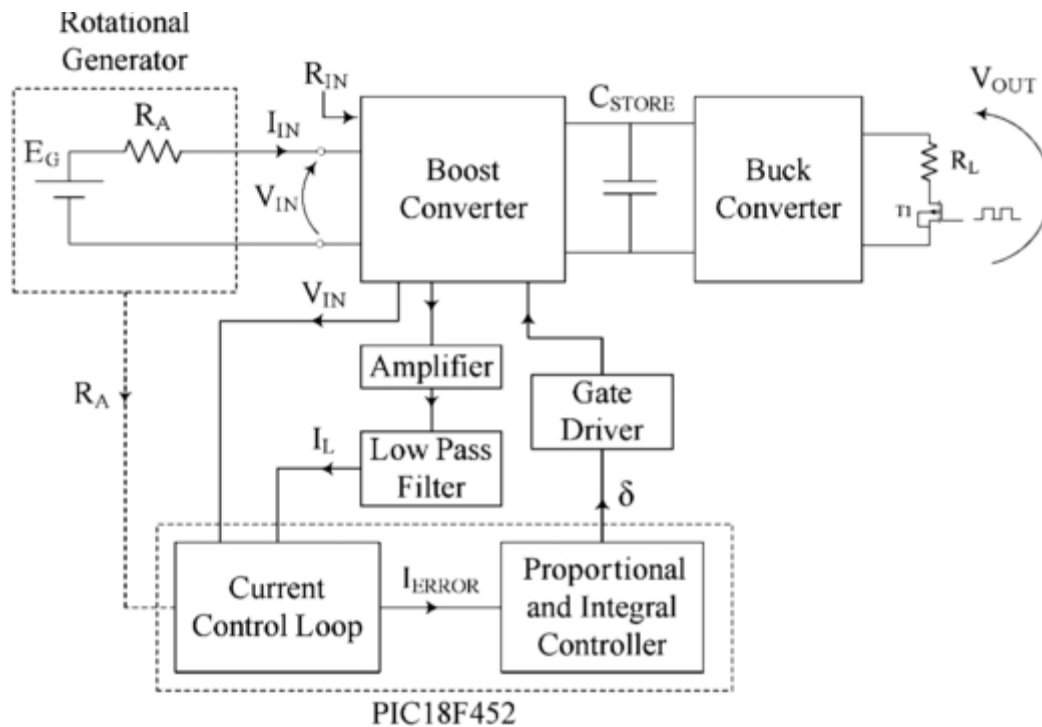

Figure: 2 Adaptive Maximum Power Point Tracking

The proposed method is compared with conventional perturb and observer (P&O) MPPT controller. The obtained results clearly demonstrates that the proposed control is more efficient than other conventional methods. This paper presents an adaptive maximum power point tracking (MPPT) algorithm for small-scale wind energy conversion systems (WECSs) to harvest more energy from turbulent wind.

- **Tracking Capability**

Evaluation of the proposed algorithm is done on a laboratory-scaled dc motor drive-based WECS emulator, 32-bit floating point digital signal controller, is used to execute the control schemes of the in-lab experimental setup. Experimental results show that tracking capability of the proposed algorithm under sudden and gradual fluctuating wind conditions is efficient and effective.

International Journal of Advanced Research in Electrical, Electronics and Instrumentation Engineering

(A High Impact Factor, Monthly, Peer Reviewed Journal)

Website: www.ijareeie.com

Vol. 7, Issue 2, February 2018

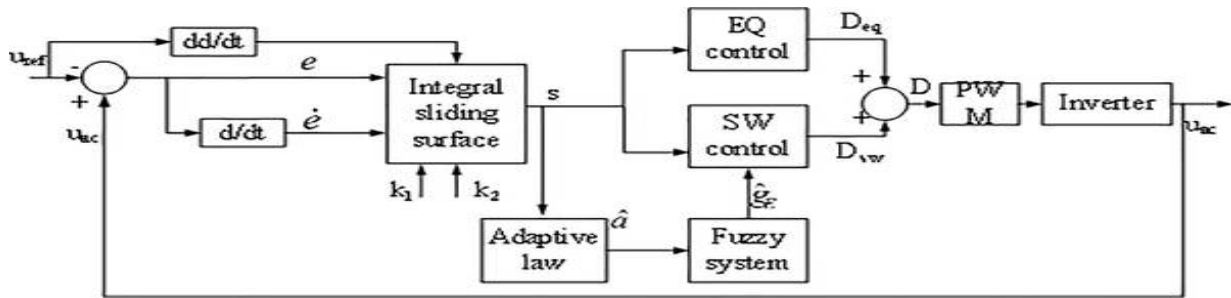

Figure: 3 Gradual Fluctuating

The proposed algorithm combines the computational behavior of hill climb search, tip speed ratio, and power signal feedback control algorithms for its adaptability over wide range of WECSs and fast tracking of maximum power point.

$$J_{\text{dopt}} / dt = T_m - T_{em} \quad (3)$$

$$P_g = \frac{3}{\pi} \frac{\sqrt{-}}{\omega_g I_{DC}} \left(k^2 - \frac{6}{\pi^2} (PL_s)^2 I^2 \right) \quad (4)$$

$$P = 1/2 \rho_{\text{air}} A v^3 C_p(\lambda, \beta) \quad (5)$$

Where,

ρ_{air} - air density
A - area swept by the blades
v - wind speed velocity

$C_p(\lambda, \beta)$ - coefficient of the wind turbine with the tip speed ratio of λ and blade pitch angle of β .

In this paper, the proposed MPPT algorithm is implemented by using buck-boost featured single-ended primary inductor converter to extract maximum power from full range of wind velocity profile.

IV. RESULT DISCUSSION AND ANALYSIS

In small-scale WECSs, power conditioning converter's control is most frequently adapting strategy to extract maximum power since pitch angle control is impractical due to their mechanical structure. In this work buck-boost featured single-ended primary inductor converter (SEPIC) converter has been used to extract maximum power from total range of wind velocity profile.

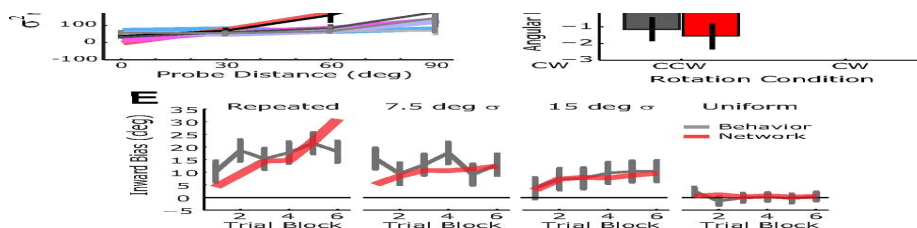

Figure: 4 distance and rotation of wind energy speed

International Journal of Advanced Research in Electrical, Electronics and Instrumentation Engineering

(A High Impact Factor, Monthly, Peer Reviewed Journal)

Website: www.ijareeie.com

Vol. 7, Issue 2, February 2018

Small-scale WECSs are main resources for DERs in micro grid systems and are usually installed at congested places with turbulent wind conditions where wind speed and direction vary frequently. Extraction of maximum power with fast tracking control strategy under fluctuating wind conditions is a challenging issue.

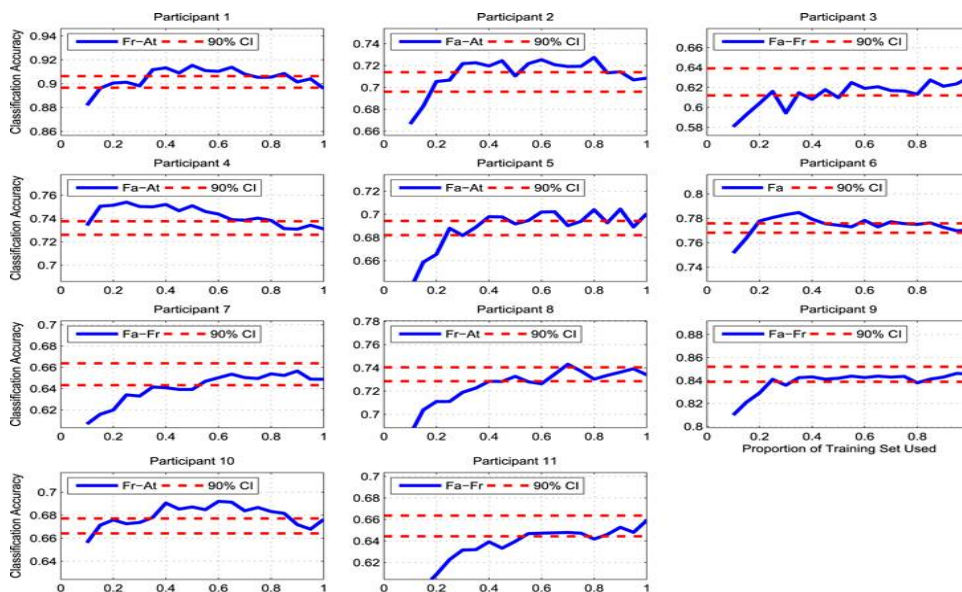

Figure 5: performance and ratio of the power tracking in wind energy

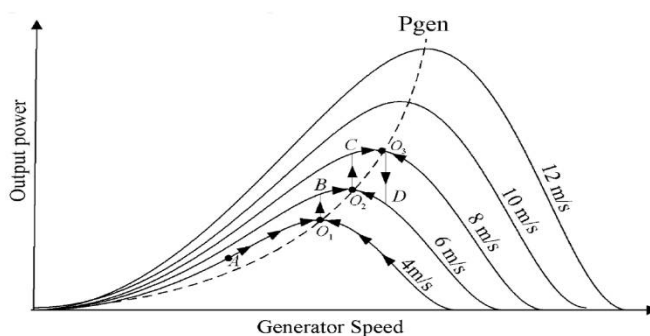

Figure: 6 dynamic generation speed

The generated active power starts increasing smoothly (together with the turbine speed) to reach its rated value. Over that time frame the turbine speed also increases. Initially, the pitch angle of the turbine blades is zero degree. Then the pitch angle is increased from 0 degree in order to limit the mechanical power. We also observed the voltage and the generated reactive power.

V. CONCLUSION

In the rest of this paper, we considered that the wind was in its optimum range of operation and it worked steady regardless of the wind speed applied to the blades. We have focused our study on the control in this area of operation allowing the wind to extract the maximum power available. We used an indirect method of MPPT control without adjustment of the rotational speed. The various controls of were detailed to provide independent control of active and reactive power while ensuring optimal operation of the turbine. To validate the modeling and control of the



ISSN (Print) : 2320 – 3765
ISSN (Online): 2278 – 8875

International Journal of Advanced Research in Electrical, Electronics and Instrumentation Engineering

(A High Impact Factor, Monthly, Peer Reviewed Journal)

Website: www.ijareeie.com

Vol. 7, Issue 2, February 2018

global wind system, we have performed a simulation for an operating point at constant wind speed. The results showed that the active and reactive power of the wind system could be controlled independently while ensuring optimal active power supplied to the grid. The proposed algorithm provides the following advantages: 1) improved dynamic response of the system; 2) prerequisite of system's optimal characteristics data is not required and hence the algorithm is adaptive; and 3) algorithm's continuous modifications on programmable memory towards optimal characteristics of the system, eliminate the possibility of system's performance degradation due to parameters variations. To extract maximum power from the wide range of wind conditions, DFIG converter is used for the implementation of proposed adaptive Maximum Power Point algorithm.

REFERENCES

- [1] Ashwani Kumar and Sanjay K. Jain, —A Review on the Operation of Grid Integrated Doubly Fed Induction Generatorl, INTERNATIONAL JOURNAL OF ENHANCED RESEARCH IN SCIENCE TECHNOLOGY AND ENGINEERING, Vol. 2, No. 6, (June 2013).
- [2] J.S.Lather, S.S Dhillon, S.Marwaha, —Modern control aspects in Doubly Fed Induction Generator based power systems: A Reviewl, INTERNATIONAL JOURNAL OF ADVANCED RESEARCH IN ELECTRICAL, ELECTRONICS AND INSTRUMENTATION ENGINEERING, Vol. 2, No. 6, (June 2013).
- [3] EvgenijeAdzic, ZoranIvanovic, Milan Adzic and Vladimir Katic, —Maximum Power Search in Wind Turbine Based on Fuzzy Logic Controll, ActaPolytechnicaHungarica ,Vol. 6, No. 1, (August 2011).
- [4] Ahmad Nadhir, AgusNaba, and Takashi Hiyama, —Intelligent Gradient Detection on MPPT Control for Variable Speed Wind Energy Conversion Systeml, ACEEE Int. J. on Electrical and Power Engineering, Vol. 02, No. 02, (August 2011).
- [5] AryuantoSoetedjo, Abraham Lomi and WidodoPujiMulayanto, —Modelling of wind energy system with MPPT control, INTERNATIONAL CONFERENCE ON ELECTRICAL ENGINEERING AND INFORMATICS, (July 2011).
- [6] Jogendra Singh Thongam and MohandOuhrouche, —MPPT control methods in wind energy conversion systemsl, Intech 978-953-307-508-2, (June 2011).
- [7] Joanne Hui, AlirezaBakhshai, and Praveen K. Jain, Fellow, —A Master-Slave Fuzzy Logic Control Scheme for Maximum Power Point Tracking in Wind Energy Systems, IEEE CONF, 978-1-4244-3384-1/10, (2010).