



# Enhancement of Investigation on Dynamic Response of Smart Grid System Using Fractional Order PID Controller

P.Yamunaa <sup>#1</sup>, R. Karthik <sup>\*2</sup>, K. Elangovan <sup>#3</sup>

Research Scholar, Dept. of EEE, Valliammai Engineering College, Kattankulathur, Chennai, India<sup>1</sup>

Associate Professor, Dept. of EEE, Valliammai Engineering College, Kattankulathur, Chennai, India<sup>2</sup>

Professor, Dept. of EEE, Valliammai Engineering College, Kattankulathur, Chennai, India<sup>3</sup>

**ABSTRACT:** In recent times, Smart grids are used along with the conventional generation systems. This work investigates closed loop response of Fractional order PID controlled Smart Grid System (FOPIDCSGS). The objective of the proposed smart grid system was to improve the dynamic response of closed loop smart grid system using suitable controller. Models were developed for Proportional Integral (PI) and fractional order PID controller (FOPID) based Smart Grid Systems (SGS). Simulation studies were performed and the result shows an improved dynamic performance by employing fractional order PID controller. The investigations indicate that FOPIDCSGS has low settling time and low steady state error.

**KEYWORD-** Smart Grid System(SGS), Fractional order PID controlled Smart Grid System (FOPIDCSGS), Four Switch Inverter(FSI), Permanent Magnet Synchronous Generator(PMSG).

## I. INTRODUCTION

The demand for electricity is increasing day-by-day. Due to rapid load growth, the need for augmentation of conventional generation brings about a continuous depletion of fossil fuel reserve. Therefore, most of the countries are looking for non-conventional / renewable energy sources as an alternative. Reduction of environmental pollution and global warming acts as a key factor in preferring renewable energy sources over fossil fuels. To reduce the greenhouse gas (carbon and nitrogenous by-products) emissions in order to counter climate change and global warming, it is necessary to look towards Renewable Energy Sources as a future energy solution. Even though Renewable Energy Sources (RES) helps to meet today's demand for electricity, its intermittent nature produces Power Quality problems, and its high penetration level in distribution systems may pose a threat to network in terms of stability and voltage regulation issues.

Electric power quality refers to maintaining a near sinusoidal power distribution bus voltage at rated magnitude and frequency. But enormous use of electronic devices creates power quality problems. The causes of power quality problems are generally complex and difficult to detect. The ideal ac line supply by the utility should be a pure sine wave of fundamental frequency, but the actual ac line supply that we receive everyday varies from the ideal one. Power quality problems caused by electronic devices are poor load factor, harmonic contents in loads, notching in load voltages, supply voltage distortion, voltage sag/swell, and voltage flicker.

# International Journal of Advanced Research in Electrical, Electronics and Instrumentation Engineering

(A High Impact Factor, Monthly, Peer Reviewed Journal)

Website: [www.ijareeie.com](http://www.ijareeie.com)

Vol. 6, Issue 10, October 2017

Such power quality problems increases cost of electricity, which affects both consumer and supplies. So in order to economic energy supplies to consumers and compensate the power quality problems the need for enhancement of power quality is essential.

## II. PROBLEM FORMULATION

Most of the work available in literature is based on design of SGS in open loop mode. Power converters are affected by various disturbances from RES. It is required to minimize the effect of fluctuations in wind speed on the output of SGS. It is also required to reduce the hardware count. Four switch inverter is proposed to reduce the hardware count. FOPID is suggested to improve time domain response.

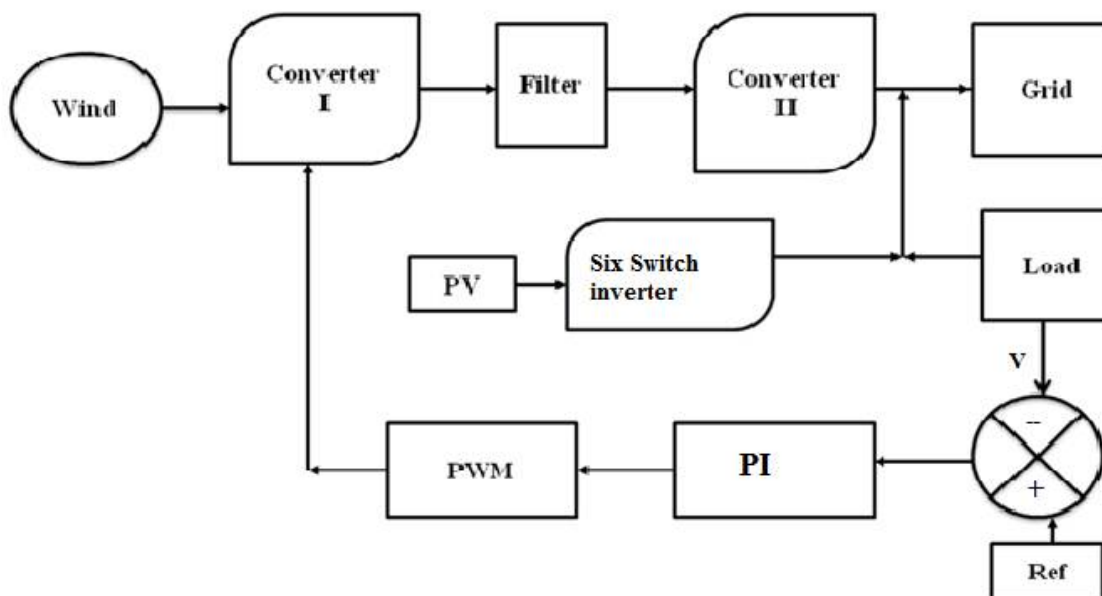

Fig.1 Block Diagram of Existing System

The block diagram of the current system is depicted in Fig 1. A six switch inverter is used for RES output which has a GRID and RES to supply set of linear and non linear loads. The proposal system uses renewable energy like Solar and Wind energy where in the turbine can be connected with DC link of Inverter (Grid Interfacing). In the proposed model, three phase four switch inverter replaces the existing three phase inverter. The PI Controller is replaced by FOPID controller. The transfer function of FOPID controller is as follows:

$$V_o(s) = [K_1 + K_2 (1/S^m) + K_3 S^n] E(S) \dots \dots \dots (1)$$

K1, K2 and K3 are proportional, integral and m and n are fractions.

# International Journal of Advanced Research in Electrical, Electronics and Instrumentation Engineering

(A High Impact Factor, Monthly, Peer Reviewed Journal)

Website: [www.ijareeie.com](http://www.ijareeie.com)

Vol. 6, Issue 10, October 2017

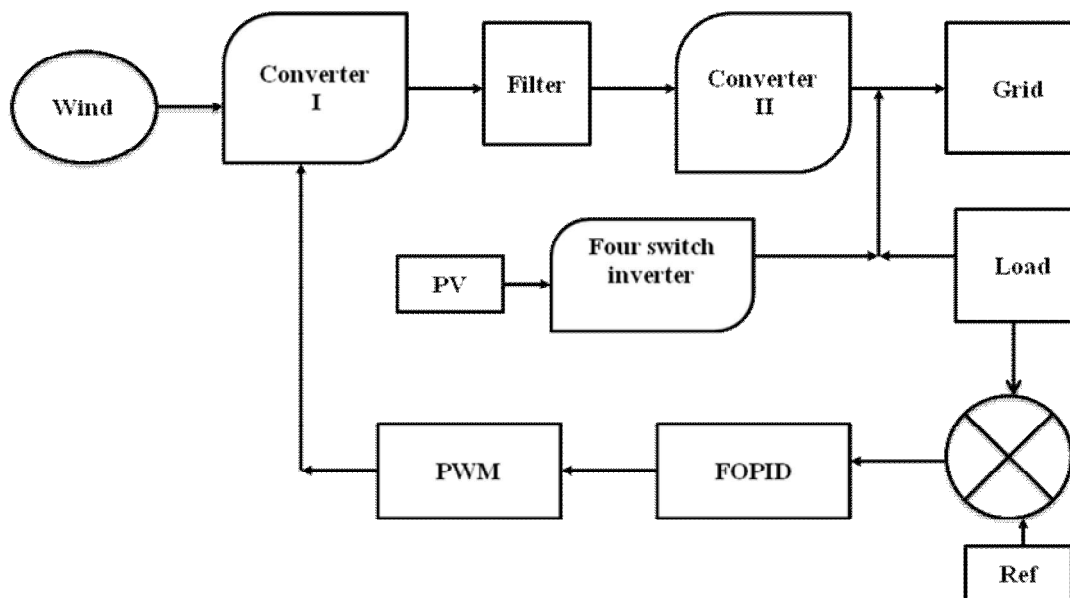

**Fig 2 Block Diagram of proposed FOPID controlled smart grid system**

The usage of Hybrid system combines the PV and PMSG where four switch voltage source inverter generates power to GRID from RES. For voltage regulation, FOPID is used in the proposed system.

### III. RESULTS AND DISCUSSION

In order to improve the performance of proposed SGS, controller like FOPID is used. MATLAB is used to simulate the proposed SGS model. The expected results on open and closed system are presented in the section.

#### 3.1. Open loop SGS

The open loop system with change in wind speed is shown in Fig 3. A fall in wind speed is considered. The Output voltage of Wind generator is shown in Fig 4. The fluctuations in the output voltage are due to the variations in speed.

# International Journal of Advanced Research in Electrical, Electronics and Instrumentation Engineering

(A High Impact Factor, Monthly, Peer Reviewed Journal)

Website: [www.ijareeie.com](http://www.ijareeie.com)

Vol. 6, Issue 10, October 2017

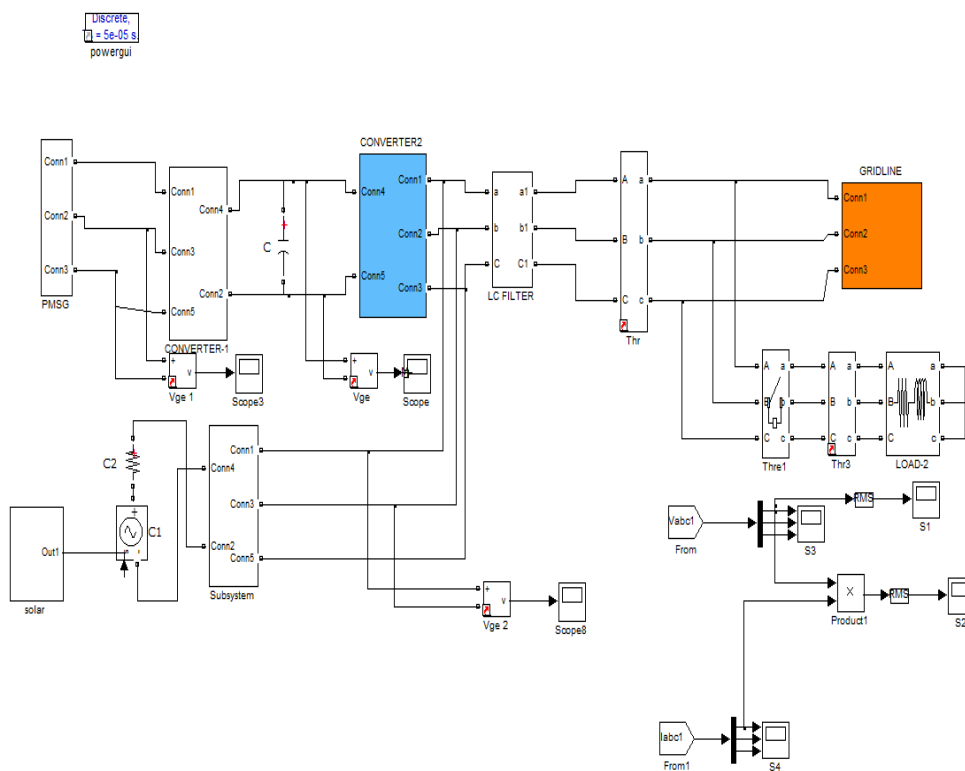

Fig 3 Open loop SGS with disturbance

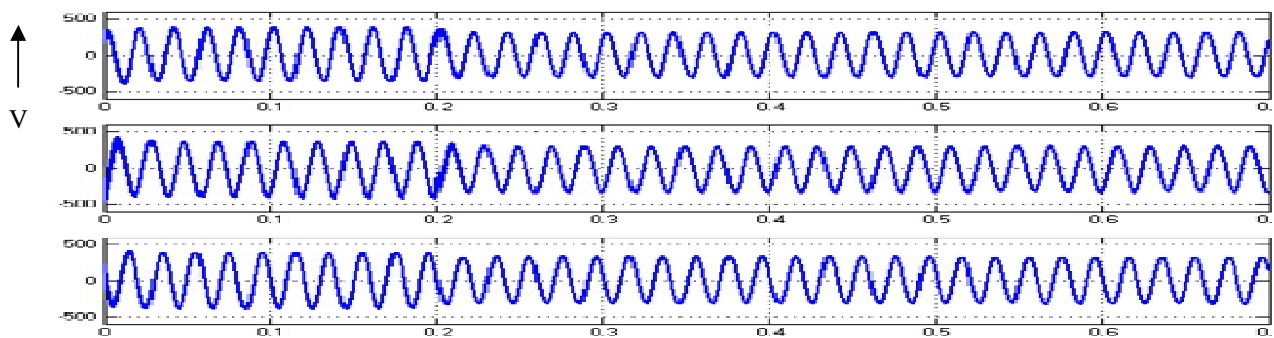

Fig 4 Output Voltage of Open Loop System

T(ms) →

The output RMS Voltage is shown in Fig 5. The RMS value reduces from 270V to 220V.

# International Journal of Advanced Research in Electrical, Electronics and Instrumentation Engineering

(A High Impact Factor, Monthly, Peer Reviewed Journal)

Website: [www.ijareeie.com](http://www.ijareeie.com)

Vol. 6, Issue 10, October 2017

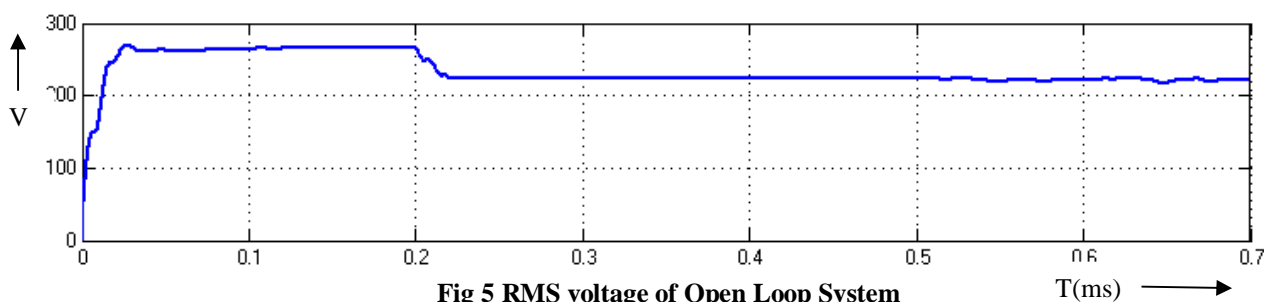

Fig 5 RMS voltage of Open Loop System

The output Current is shown in Fig 6. The peak value of current reduces from 3A to 2A.

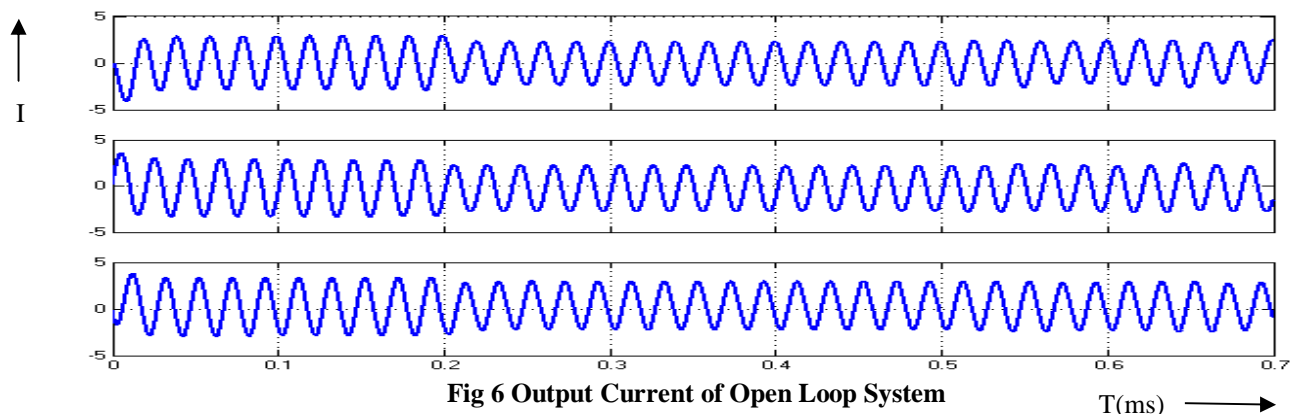

Fig 6 Output Current of Open Loop System

The output power is shown in Fig 7 and its value is 420 Watts. The fluctuations in the output power are due to the fluctuations in wind speed.

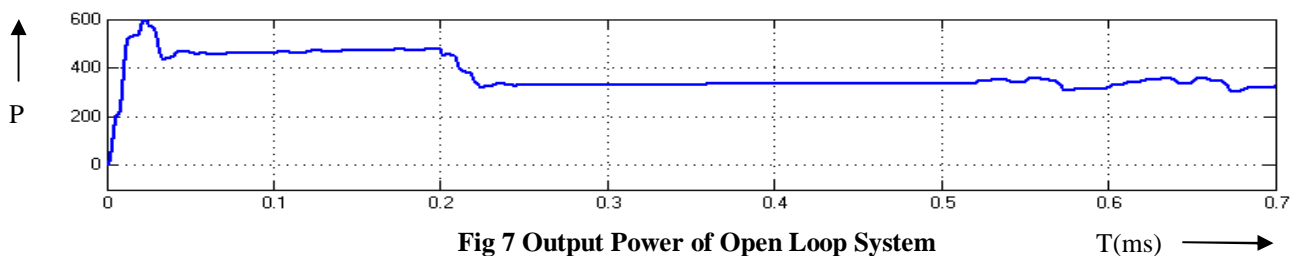

Fig 7 Output Power of Open Loop System

### 3.2 Closed loop SGS with PI Controller

The closed loop SGS system with PI controller system is shown in Fig 8. Load voltage is sensed and it is compared with the reference voltage. The error is given to the PI controller. The output of PI compensator is given to the comparator which updates the width of the pulse applied to the source side converter. The output voltage of wind generator system is shown in Fig 9. The RMS voltage is shown in Fig 10. The output current is shown in Fig 11. The output power is shown in Fig 12 and its value is 1500 W. It can be seen that the fluctuations in output voltage are reduced in closed loop system by employing a PI controller.

# International Journal of Advanced Research in Electrical, Electronics and Instrumentation Engineering

(A High Impact Factor, Monthly, Peer Reviewed Journal)

Website: [www.ijareeie.com](http://www.ijareeie.com)

Vol. 6, Issue 10, October 2017

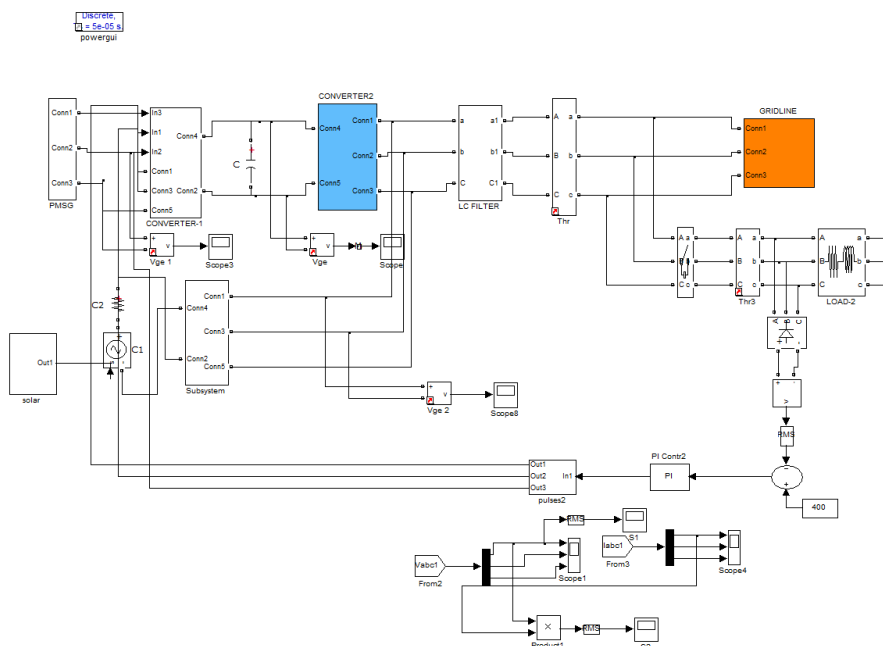

**Fig 8 Closed Loop SGS with PI Controller**

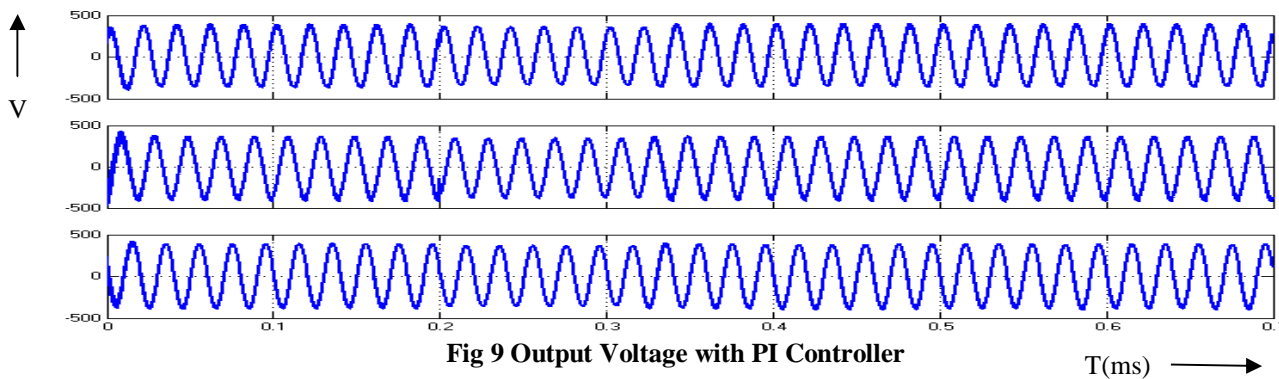

**Fig 9 Output Voltage with PI Controller**

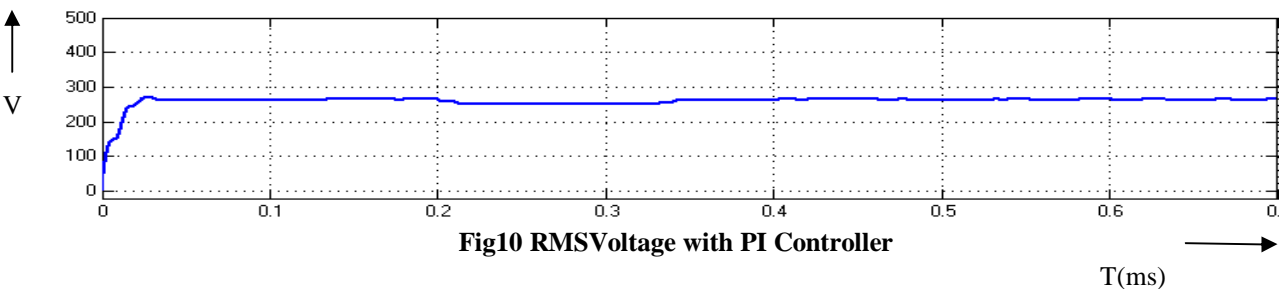

**Fig10 RMS Voltage with PI Controller**

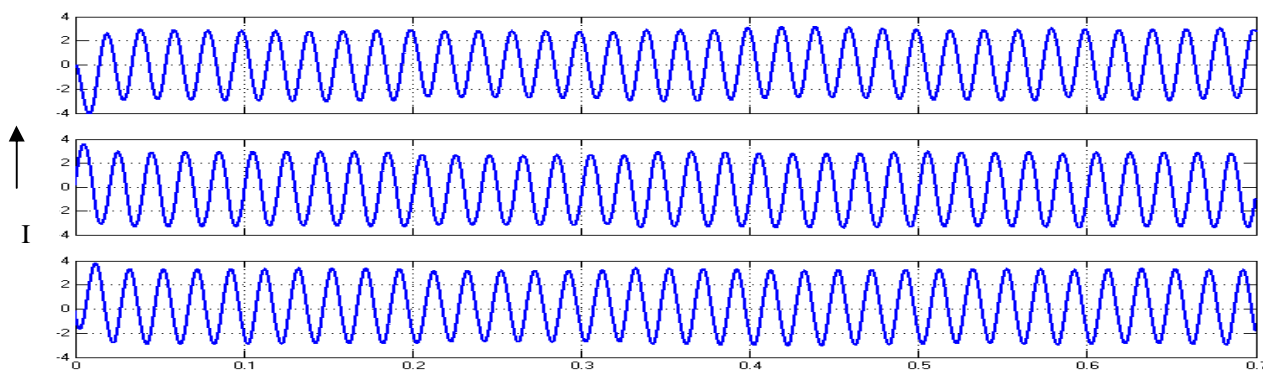

**Fig 11 Output current waveforms of Closed Loop System with PI Controller**

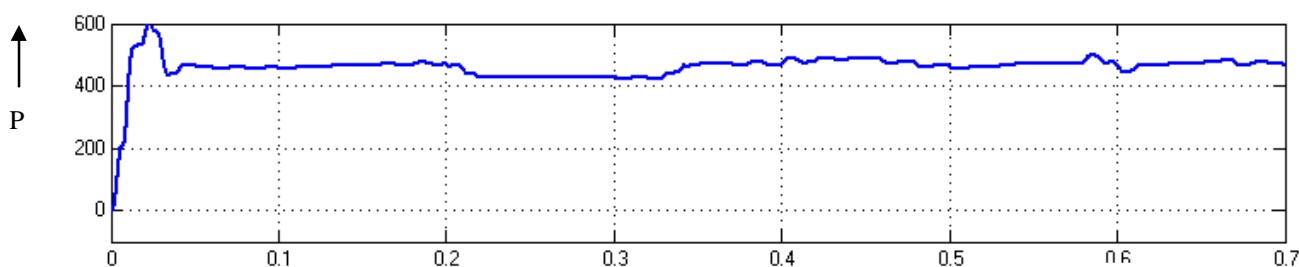

**Fig 12 Output power of Closed Loop System with PI Controller**

### 3.3 Closed loop SGS with FOPID

The peak over shoot and settling time are higher with PI controller SGS. FOPID may be used to reduce over shoot and settling time. The closed loop SGS system with FOPID is shown in Fig 13. The output voltage of rectifier is shown in Fig 14 and its value is 80 V.

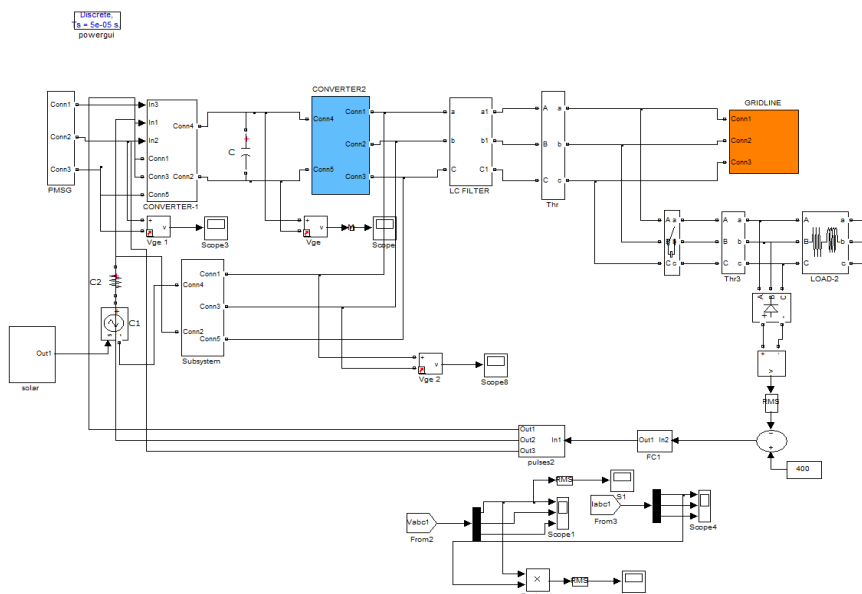

**Fig 13 Closed Loop SGS with FOPID Controller**



# International Journal of Advanced Research in Electrical, Electronics and Instrumentation Engineering

(A High Impact Factor, Monthly, Peer Reviewed Journal)

Website: [www.ijareeie.com](http://www.ijareeie.com)

Vol. 6, Issue 10, October 2017

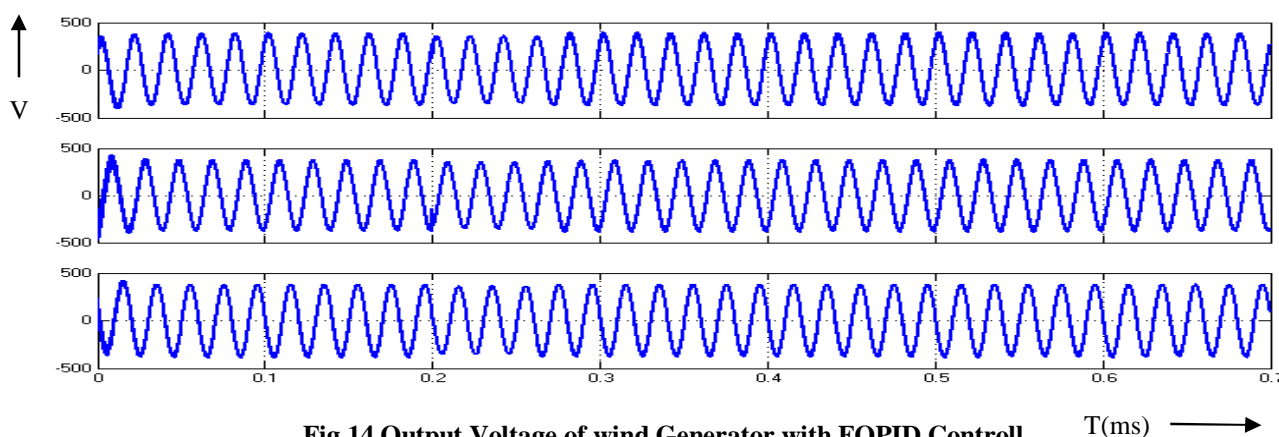

Fig 14 Output Voltage of wind Generator with FOPID Control

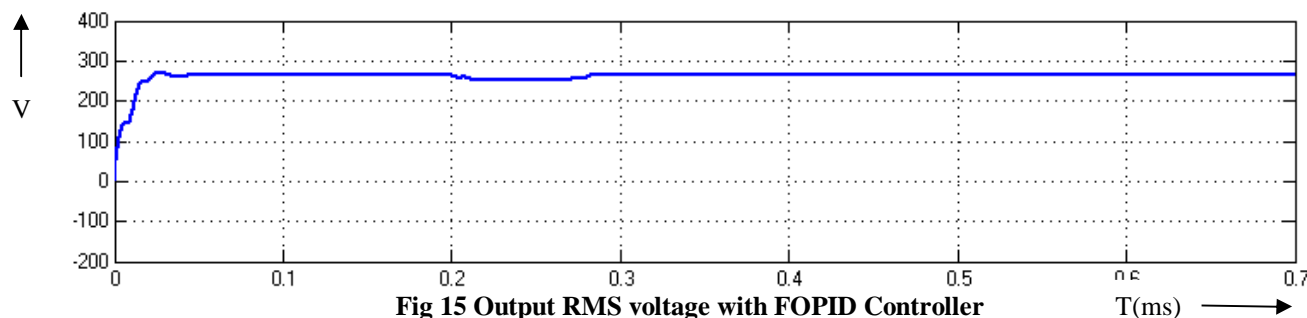

Fig 15 Output RMS voltage with FOPID Controller

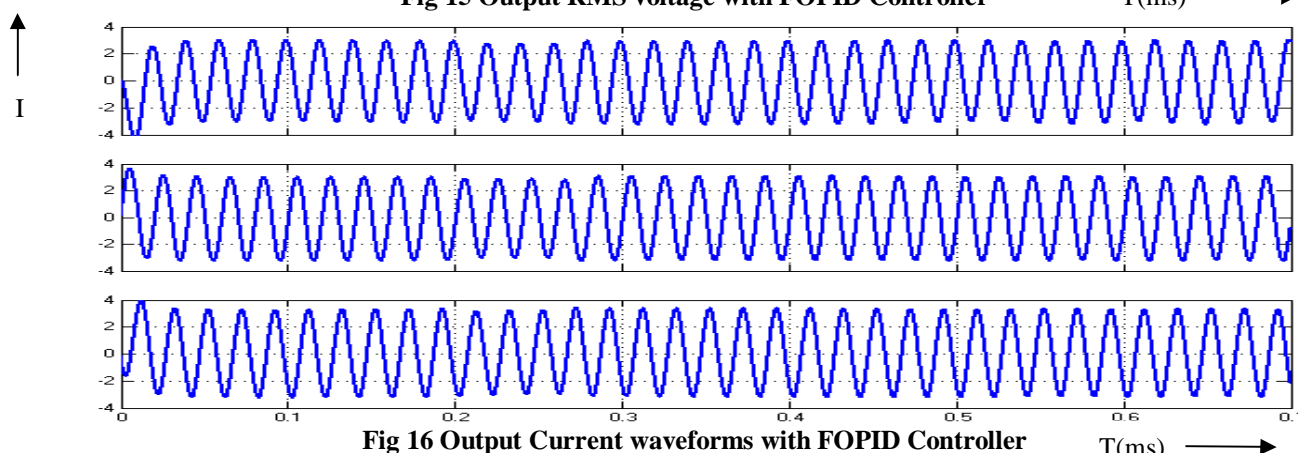

Fig 16 Output Current waveforms with FOPID Controller

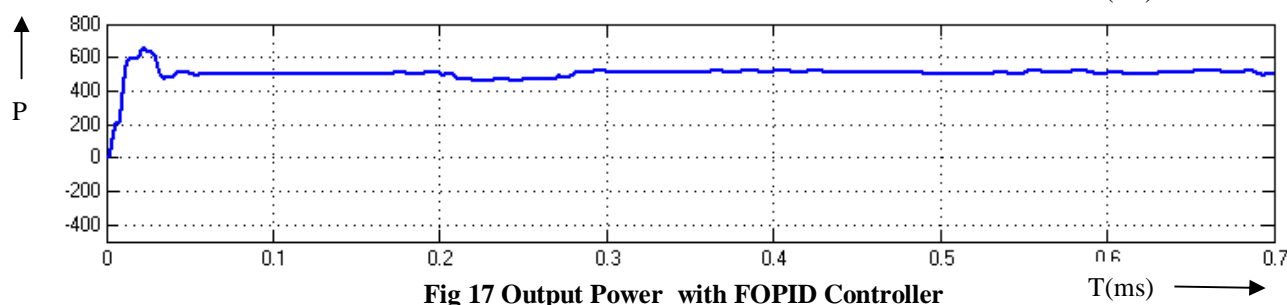

Fig 17 Output Power with FOPID Controller





# International Journal of Advanced Research in Electrical, Electronics and Instrumentation Engineering

(A High Impact Factor, Monthly, Peer Reviewed Journal)

Website: [www.ijareeie.com](http://www.ijareeie.com)

Vol. 6, Issue 10, October 2017

Controllers	Rise time (s)	Peak time (s)	Settling time (s)	Steady state error (v)
PI	0.23	0.28	0.34	6.4
FOPID	0.22	0.24	0.26	3.1

Table-1 Summary of Time Domain parameters with PI & FOPID Controllers

The summary of time domain parameters is shown in Table-1. The settling time is reduced from 0.34 to 0.26 Secs and steady state error is reduced from 6.4 to 3.1 V. The response with FOPID is much better than PI controlled SGS. The parameters used for simulation are given in Table-2.

<b>V<sub>in</sub></b>	<b>100V</b>
<b>C</b>	<b>3000 μF</b>
<b>L<sub>1</sub>,L<sub>2</sub>,L<sub>3</sub></b>	<b>200mH</b>
<b>C<sub>1</sub>,C<sub>2</sub>,C<sub>3</sub></b>	<b>0.1μF</b>
<b>L<sub>4</sub></b>	<b>100mH</b>
<b>R<sub>L</sub></b>	<b>100Ω</b>
<b>V<sub>0</sub></b>	<b>415V</b>
<b>K<sub>p</sub></b>	<b>0.01</b>
<b>K<sub>i</sub></b>	<b>0.2</b>

Table 2 Parameters Used for Simulation

## IV. CONCLUSION

SGS controlled by PI & FOPID are modelled and simulated using simulink. The simulation results of open loop system, closed loop System with PI and FOPID are presented. Simulation and numerical results have been presented with supporting comparisons. The settling time is reduced to 0.26s and the steady state error is reduced to 3.1 volt using FOPID controller. Therefore the response of FOPIDSGS is superior to PISGS. The advantages of proposed system are reduced number of switches and improved response. The contribution of this work is to reduce number of switches using four switch inverter.

The present work deals with comparison of PI & FOPID controlled SGS systems. The comparison of PI and proportion resonant controlled SGS system will be focused future. The effectiveness of SGS system can be improved by using two loop control strategy.

## REFERENCES

- [1] Parimi, A.M., Elamvazuthi, I. and Saad, N,'Damping of Inter Area Oscillations Using Interline Power Flow Controller Based Damping Controllers'. *IEEE 2nd International Power and Energy Conference*,pp 67-72,(2008).
- [2] H. Glavitsch and J. Stoffel, 'Automatic generation control,' *Electrical Power and Energy Systems* vol.2, no. 1, pp. 21-28,(1980).
- [3] H. Shayeghi, H. A. Shayanfar, 'A. Jalili, "Load frequency control strategies: A state-of-the-art survey for the researcher',*Energy Conversion and Management*, vol. 50, pp. 344–353, (2009).
- [4] Chatterjee K., 'Design of Dual Mode PI Controller for Load Frequency Control', *International Journal of Emerging Electric Power System*. Vol. 11, Issue 4, Article 3, (2010).
- [5] H. Shabani, B. Vahidi, and M. Ebrahimpour, 'A robust PID controller based on imperialist competitive algorithm for load-frequency control of power systems,' *ISA Transactions*, vol. 52, pp. 88-95, (2013).
- [6] T. C. Yang, Z. T. Ding, and H. Yu, 'Decentralized Power System load frequency control beyond the limit of diagonal dominance,' *Electrical Power and Energy Systems*, vol. 24, pp. 173-184,(2002).
- [7] Y. Luo, Y. Chen, and Y. Pi, 'Experimental study of fractional order proportional derivative controller synthesis for fractional order systems,' *Mechatronics*, vol. 21, no. 1, pp. 204–214, (2011).



ISSN (Print) : 2320 – 3765  
ISSN (Online): 2278 – 8875

# International Journal of Advanced Research in Electrical, Electronics and Instrumentation Engineering

*(A High Impact Factor, Monthly, Peer Reviewed Journal)*

Website: [www.ijareeie.com](http://www.ijareeie.com)

**Vol. 6, Issue 10, October 2017**

- [8] H. Li, Y. Luo, and Y. Chen, 'A fractional order proportional and derivative (FOPD) motion controller: tuning rule and experiments,' IEEE Transactions on Control Systems Technology, vol. 18, no. 2, pp. 516–520, (2010).
- [9] C. H. Lee and F. K. Chang, "Fractional-order PID controller optimization via improved electromagnetism-like algorithm," Expert Systems with Applications, vol. 37, no. 12, pp. 8871–8878, 2010.
- [10] C. A. Monje, B. M. Vinagre, V. Feliu, and Y. Chen, 'Tuning and auto-tuning of fractional order controllers for industry applications,' Control Engineering Practice, vol. 16, no. 7, pp. 798–812, (2008).
- [11] Marco Liserre, Thilo Sauter, and John Y. Hung, "Future Energy Systems", IEEE Industrial Electronics Magazine, (2010).
- [12] T.Samad and A.M. Annaswamy, 'The Impact of control technology- Control for renewable energy and Smart Grid' www.ieeecs.org. (eds), (2011).