



Study of Grid Power Flow in a DFIG based Wind Turbine Generator System

Santhosh Raj.R¹

PG Student [Power Systems], Dept. of EEE, Govt. Engineering College, Thrissur, Kerala, India¹

ABSTRACT: Wind power generation is one of the most attractive of the renewable energy sources due to its availability in different areas and environmental friendly nature. The integration of renewable energy sources such as wind energy system with utility grid is an important issue in the present power system. Doubly Fed Induction Generator is having (20-30%) percentage of more energy output than other variable speed wind turbine generator systems. In this paper a grid connected DFIG based wind Turbine Generator System is proposed during varying wind speed conditions. The machine side converter and grid side converter along with battery storage device and capacitor in DC link reduces the power fluctuations in grid due to varying nature of wind. The control method in this paper is based on the theory of controlling the 'd' and 'q' axis components of current for both MSC and GSC. The overall proposed strategy is simulated in MATLAB-SIMULINK software and is analyzed.

KEYWORDS: Wind Turbine Generator System(WTGS),Doubly Fed Induction Generator(DFIG),Wind Turbine(WT),Battery Storage Device(BSD),Machine Side Converter(MSC) and Grid Side Converter(GSC)..

I.INTRODUCTION

The renewable energy has many advantages over the non renewable energy because of its non polluting and environmental friendly nature. The main renewable energy sources are solar,wind,and tidal. Among these sources, wind energy receives much interest all over the world and DFIG based Wind turbine(WT) is widely used in most WTGS.

Variable speed operating wind turbine is much better than fixed speed operating wind turbine. There are mainly three types of generators used in the WTGS. Doubly Fed Induction Generator (DFIG) based WTGS, Squirrel Cage Induction Generator (SCIG) based WTGS and Permanent Magnet Synchronous Generator (PMSG) based WTGS. A DFIG based WTGS has many advantages over SCIG and PMSG based WTGSs. Improved efficiency, ability to control electrical torque, ability to control active and reactive power with the of power electronic converters, reduced losses and easy power factor correction [1].

Wind power system use a DFIG consist of a wound rotor induction generator and an AC/DC/AC, IGBT based back to back converters. The stator winding of wound rotor machine is directly connected to the grid while the rotor is fed at variable frequency through AC/DC/AC converter [2].A capacitor connected in the DC link acts as the DC voltage source..Back to back converters consist of a machine side converter (MSC) and a grid side converter (GSC).The MSC takes the variable frequency and voltage and converts into a DC voltage. The GSC has the voltage conversion from the DC link as input and AC voltage at the grid as output.

The grid connectivity is a major problem due to the varying nature of wind speed[3]. In the proposed model a battery storage device (BSD) is introduced in the DC link along with a capacitor. Here three modes of operations are possible. When the wind speed is greater than the rated wind speed, the stator and rotor of DFIG machine is capable of injecting active power to the grid. When the wind speed is less than the rated wind speed, the stator is only capable of supplying the power. The additional amount of power required to the grid is supplied by the battery storage device(BSD). When the wind is in rated condition, the rated power(the power which has to be maintained constant in the grid) is supplied by the stator itself. Thus the grid is always supplied with constant power irrespective of varying wind speed.

This paper is organized as follows. Section II presents DFIG based WTGS without BSD.Section III presents DFIG based WTGS with BSD. Section IV presents conclusion.

II. DFIG BASED WTGS WITHOUT BATTERY STORAGE DEVICE (BSD)

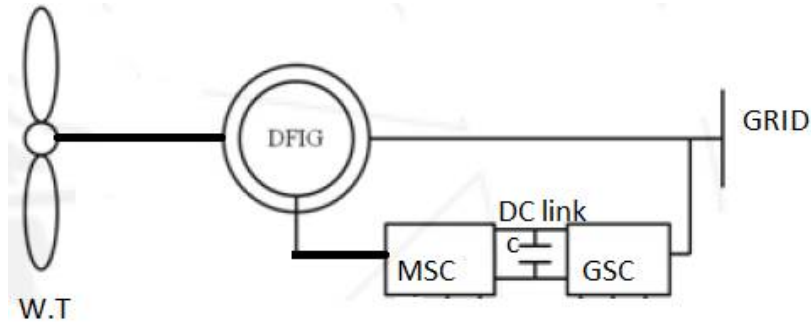

Fig.(1) Block diagram of DFIG -WTGS without BSD

In a DFIG, both the stator and rotor are able to supply active power, but the direction of this power flow through the rotor circuit is dependent on the wind speed and accordingly the generator speed. In this proposed DFIG based WTGS, a wound rotor asynchronous generator is used its stator winding is directly connected to the grid and rotor windings connected to the grid via sliprings and voltage source converters(VSC). Here an AC/DC/AC IGBT based PWM converters act as voltage source converters. The voltage source converters consist of machine side converter (MSC) and grid side converter (GSC). A capacitor connected in the DC link is used in order to remove ripples and keep the DC voltage constant.

(A) DESIGN OF WIND TURBINE.

Wind turbine converts the kinetic energy of the wind into mechanical energy [4].

$$P_w = 0.5 \rho_{air} \pi R^2 V_{wind}^3 \quad (1)$$

Where,

ρ_{air} - Air density (kg/m^3)-1.225 kg/m^3 .

R-rotor radius (m)

V_{wind} - Wind speed (m/s)

Then the mechanical power of wind turbine captured from the wind power can be calculated as,

$$P_{mech} = C_p(\lambda, \beta) * P_w \quad (2)$$

$$ie, P_{mech} = 0.5 C_p(\lambda, \beta) * \rho_{air} \pi R^2 V_{wind}^3 \quad (3)$$

The value of C_p is dependent on Tip speed ratio(λ) and blade pitch angle(β). Practically the value of C_p lies between (0.52 to 0.55)

$$\text{The Tip speed ratio is defined as } (\lambda) = \omega.R/V_{wind} \quad (4)$$

Where,

ω .-Rotational speed of the generator.

From equation(4) it is clear that the Tip Speed Ratio (TSR) can be adjusted by controlling the (ω) rotational speed of the generator, leading to the control of power coefficient (C_p) as well as generated output power of the wind turbine. To get the maximum power coefficient (C_p), blade pitch angle($\beta=0$) should be zero. In this paper wind turbine model for different wind speeds and fixed pitch angle at $\beta=0$.

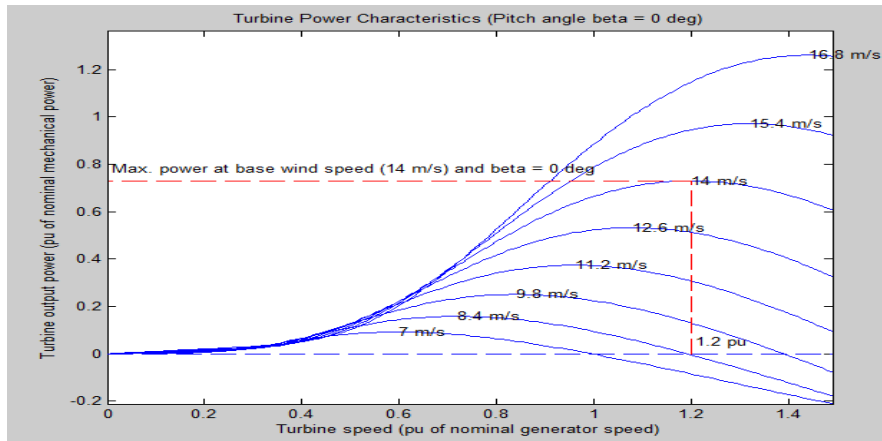

Fig.(2) Wind Turbine Power Characteristics.

Fig(2) shows the characteristics between the Wind turbine output power and the turbine speed for different speeds at zero degree pitch angle($\beta=0^0$).From the characteristics it is clear that maximum power occurs at base wind speed 14m/s at pitch angle $\beta=0^0$ with 1.2p.u base rotational speed.

(B) CONTROL STRATEGY

CONTROL OF MACHINE SIDE CONVERTOR(MSC)

The MSC is used to extract maximum power from the wind turbine also for maintaining low reactive power in the DFIG.The Proportional-Integral(PI) controller is used for the regulation of reactive power and rotor speed. Initially, reference direct axis(d-axis)rotor current $-I_{rd.ref}$ and reference quadrature axis(q-axis) rotor current $-I_{rq.ref}$ are generated using the equation.

$$I_{rd.ref}=(K_p.msc+K_i.msc/s)(Q_{grid}-Q_{grid.ref}) \quad (5)$$

$$I_{rq.ref}=(K_p.msc+K_i.msc/s)(\omega_r-\omega_{r.ref}) \quad (6)$$

Where,

$K_p.msc$ -Proportional gain of machine side converter(MSC)

$K_i.msc$ -Integral gain of machine side converter (MSC)

Q_{grid} -Instantaneous grid reactive power.

$Q_{grid.ref}$ -Reference grid reactive power.(For maintaining reactive power of grid to zero, $Q_{grid.ref}$ is taken as zero)

ω_r -Instantaneous rotor speed.

$\omega_{r.ref}$ -Reference rotor speed.

These reference rotor currents are then compared with the actual rotor currents and the error is processed with a PI controller and finally clock pulses are generated with the help of a Hysteresis Current controller.

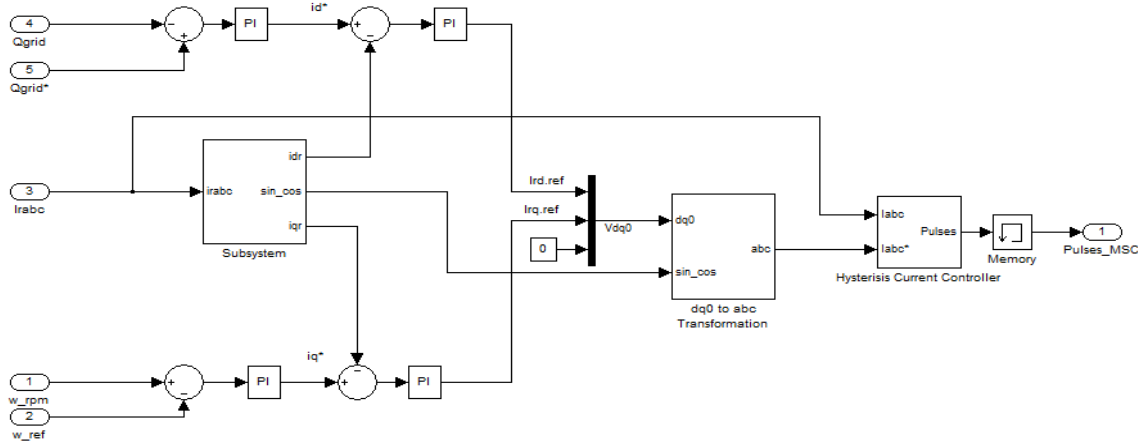

Fig(3) Simulink model of MSC.

CONTROL OF GRID SIDE CONVERTOR (GSC)

The GSC has important role to ensure the active and reactive power delivered to the grid effectively. The grid power should be maintained at a constant value and this is given as the reference power. This is then compared with the actual grid power at any instant.

The PI controller is used to generate q-axis component of reference grid current ($I_{gq.ref}$)

$$I_{gq.ref} = (K_p.gsc + K_i.gsc/s)(P_{grid} - P_{grid.ref}) \quad (7)$$

d-axis component of reference grid current, $I_{gd.ref} = 0$ (8) for unity power factor operation.

Where,

$K_p.gsc$ - Proportional gain of grid side converter(GSC).

$K_i.gsc$ -Integral gain of grid side converter (GSC).

P_{grid} –Instantaneous active grid power.

$P_{grid.ref}$ -Reference active grid power.

The three phase PLL is used to extract the grid side phase angle. Finally the reference grid current is compared with instantaneous value grid current and using a Hysteresis Current controller, corresponding clock pulses are generated.

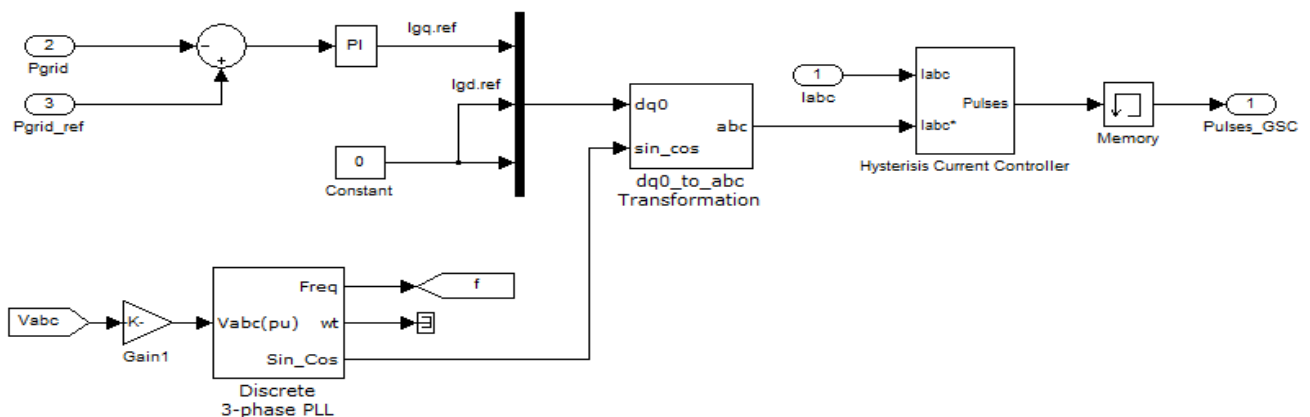
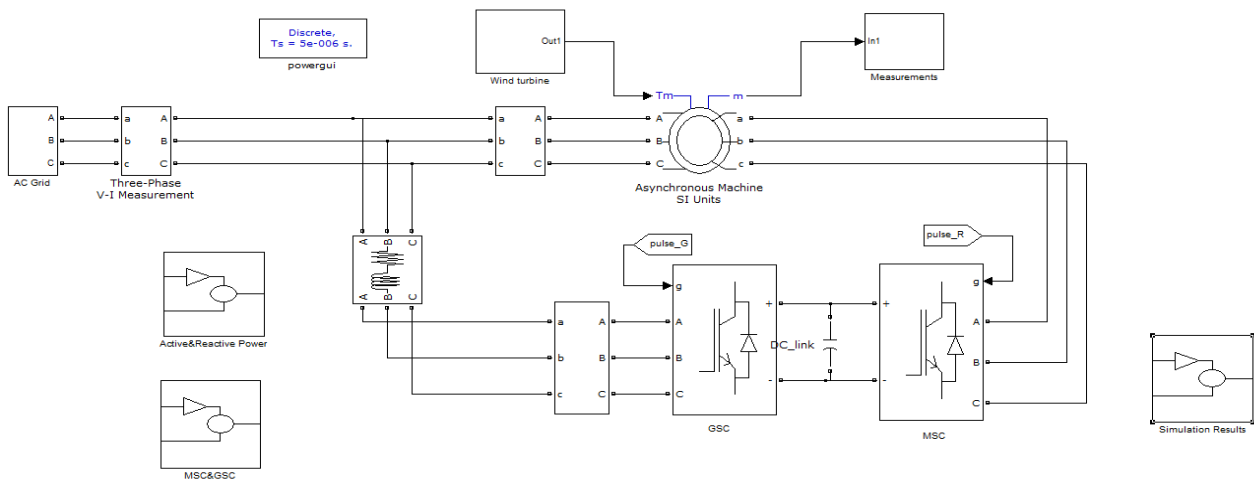

Fig.(4) Simulink model of GSC

(C) SIMULINK MODEL OF DFIG BASED WTGS WITHOUT BSD.



Fig(5) Simulink model of DFIG-WTGS Without BSD

(D) SIMULATION RESULTS DFIG BASED WTGS WITHOUT BSD.

(1) WIND SPEED

During the simulation the wind speed is varied above rated wind speed (20m/s), rated wind speed(14m/s) and below rated wind speed (10m/s).The wind speed is kept 10m/s up to 2.5Sec then the wind speed is changed to 20m/s.At 4Sec wind speed is reduced to 14m/s.Finally the wind speed is reduced to zero at 6Sec.Thus a varying wind speed is applied to wind turbine.

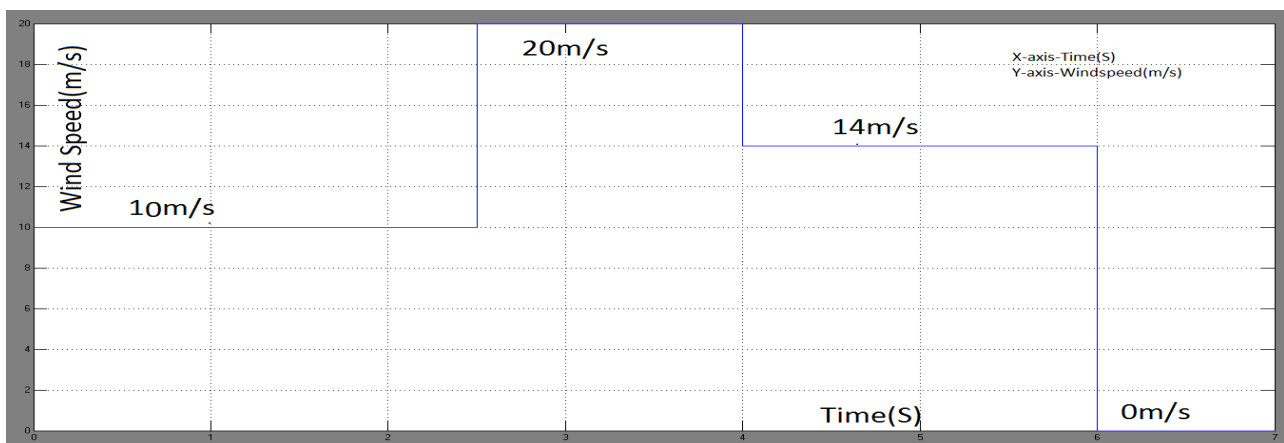

Fig.(6) Wind Speed Variations.

(2) ACTIVE POWER IN THE GRID

Initially the wind speed is 10m/s then power injected to the grid is only 300W.If the wind speed is increased to 20m/s,at this time power supplied by the DFIG is 1200W .When wind speed is 14m/s the machine is capable of

producing 500W only .At time 6Sec the wind speed is reduced to zero during this time the power injected is only zero watts. Thus it is clear that active power in the grid is varying with respect to wind speed.

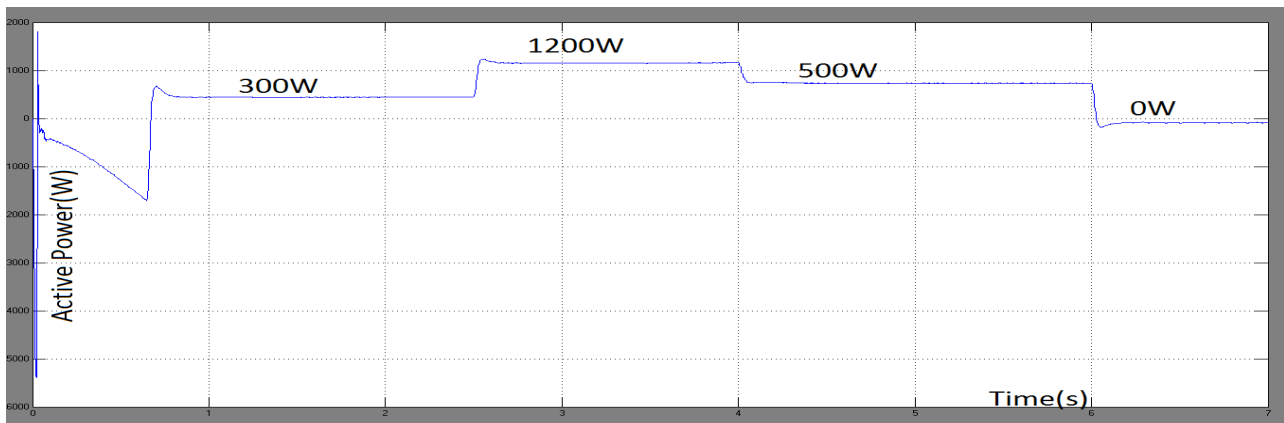

Fig.(7) Active Power in the Grid.

(IV) DFIG BASED WTGS WITH BATTERY STORAGE DEVICE (BSD)

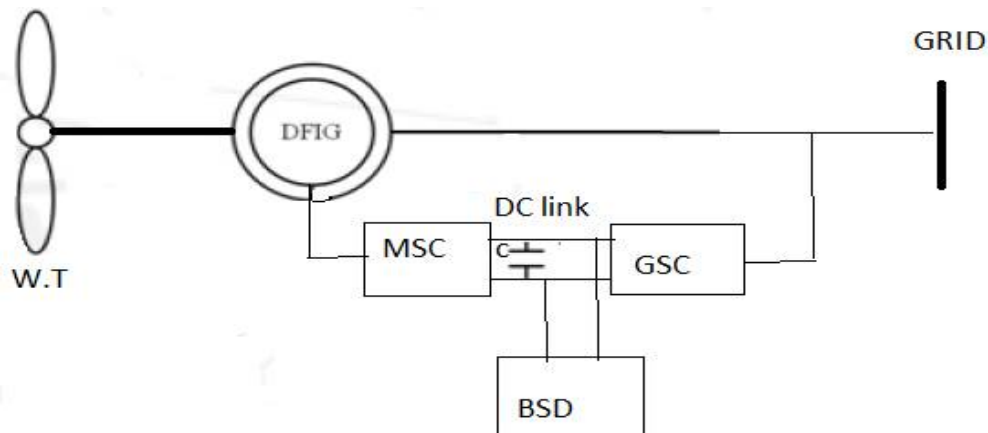

Fig.(8)Block diagram of DFIG –WTGS With BSD

In this proposed DFIG based WECS,a battery storage device(BSD) is placed in between the MSC and RSC.

(A) DESIGN OF BATTERY STORAGE DEVICE(BSD)

Lead acid batteries are used in many electrical systems to store or deliver electrical energy .There have been many proposals for lead-acid battery models. One of these is the Thevenin equivalent circuit [5].Thevenin battery model is used in this work , which consists of no load voltage (V_0),internal resistance (R_1),parallel combination of C and R_2 . C represents the capacitance of parallel plates and R_2 represents the non linear resistance contributed by the resistance of plate to electrolyte. R_2 in parallel with C represents self discharging of the battery. The battery is an energy storage device. So it is represented in kilo watt hour(kWh) .

The value of $C = kWh * 3600 * 10^3 / 0.5(V_{max}^2 - V_{min}^2)$ (9).Where V_{max} and V_{min} are the maximum and minimum no load voltage of the battery under fully charged and discharged condition.

(2) ACTIVE POWER SUPPLIED BY THE DFIG

During starting, the wind speed is 10m/s .At this time, the DFIG supplied power is nearly 400W that is less than rated power of the grid. Then wind speed is increased to 20m/s at this time the machine will inject nearly 1300W that is greater than rated power of the grid. When the wind speed is reduced to 14m/s(rated wind speed) power supplied by the machine is 1000W(rated grid power). At time 6Sec the wind speed is reduced to zero during this time the power injected is only zero watts.

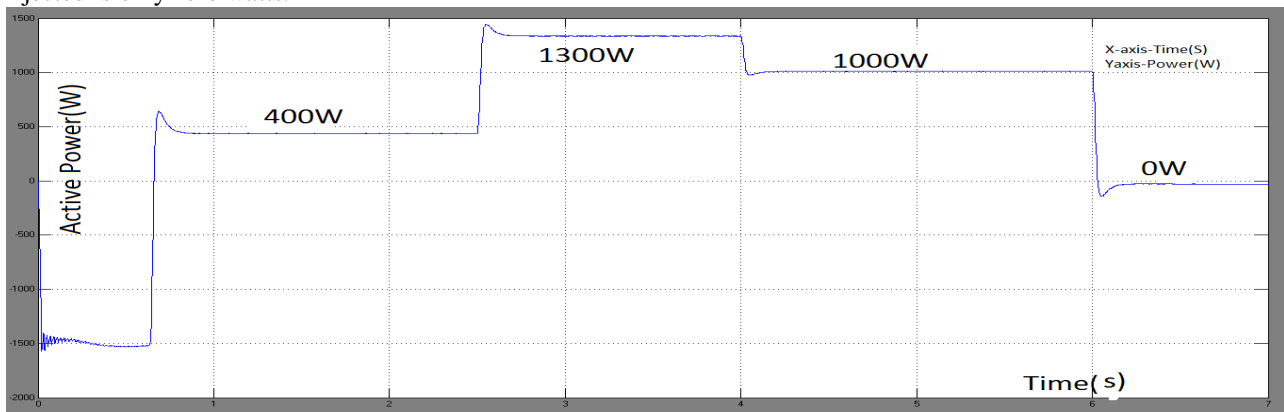

Fig(12) Active Power Supplied by the DFIG Machine

(3) ACTIVE POWER SUPPLIED BY THE BATTERY

During starting, the wind speed is 10m/s at this time battery injected power is nearly 600W in order to maintain constant power in the grid. When wind speed is raised to 20m/s at this time the excess power(300W) produced by the DFIG is stored in the battery. When time t=4 Sec the wind speed is rated wind speed ie, 14m/s. At this condition battery neither inject nor store the active power. Then at time t=6Sec the wind speed is reduced to zero during this mode the whole rated power (1000W) to the grid is supplied by the battery storage device (BSD).

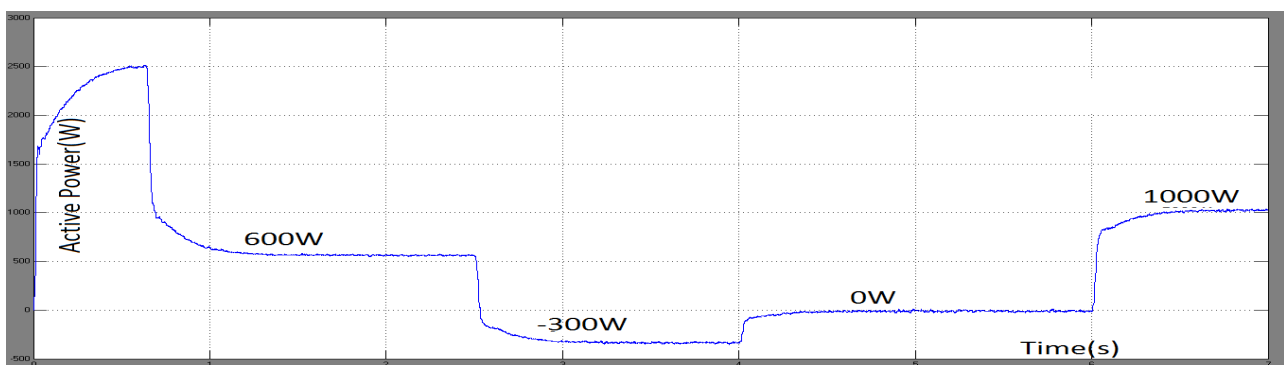

Fig.(13) Active Power Supplied by the Battery.

(4) ACTIVE POWER IN THE GRID

During starting, the wind speed is less than rated wind speed at this time the DFIG injected power is nearly 400W, the additional amount of power 600W supplied by the battery in order to maintain constant power in the grid. When wind speed is increased to 20m/s at this time the DFIG produced nearly 1300W the excess 300W stored in the battery. When time t=4Sec the wind speed is rated wind speed (14m/s) at this time the machine is capable of injecting 1000W. Then at time t=6Sec the wind speed is reduced to zero during this time the whole power 1000W to the grid is

supplied by the battery .Thus the proposed system is capable of maintaining constant power (1000W) in the grid independent of wind speed fluctuations.

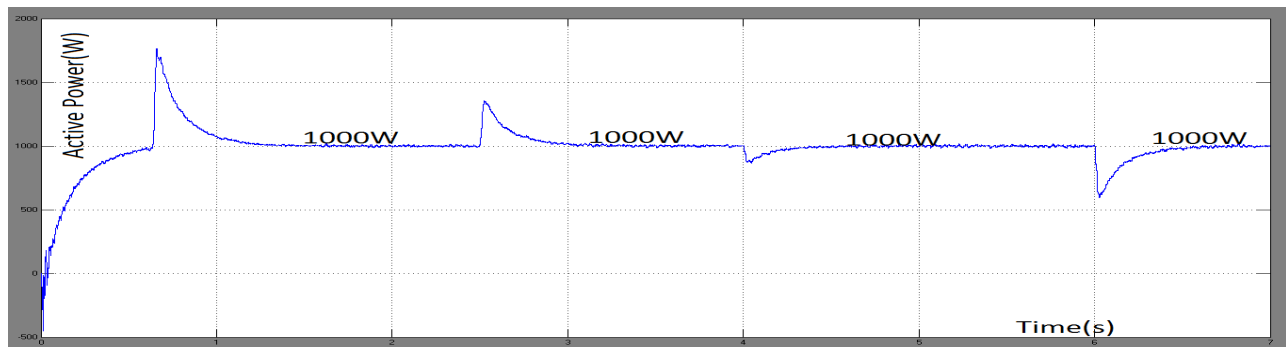

Fig.(14) Active Power in the Grid

(5) REACTIVE POWER IN THE GRID

The grid reactive power is maintained to zero for unity power factor operation and it is independent of wind speed variations.

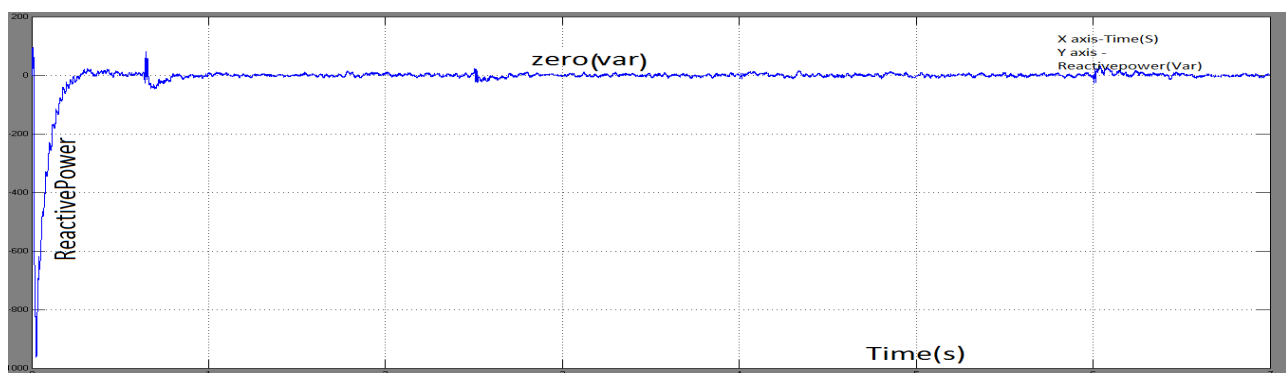

Fig.(15) Reactive Power in the Grid.

V. CONCLUSION

During the operation of DFIG based WTGS without battery storage device ,grid power is fluctuating due to the varying nature of wind speed.So here we introduce a battery storage device (BSD). A DFIG based WTGS with battery storage device (BSD) and a capacitor in DC link has been simulated at different wind speeds. When the wind speed is above rated speed condition, the excess power produced is stored in battery storage device. During lower wind speed condition the stored energy is utilized to maintain grid power constant. Thus it has been observed that the grid power is levelled with the help of a battery storage device and a capacitor in DC link.

REFERENCES

- [1] Yu Zou, Malik E, Elbuluk and Yilmaz Sozer, , "Simulation Comparisons and Implementation of Induction Generator Wind Power Systems" IEEE Transactions on Industry applications., vol. 49, no. 3, May/June 2013.
- [2] M. Boutoubat , L. Mokrani "Control of a wind energy conversion system equipped by a DFIG for active power generation and power Quality improvement," Renewable Energy 50 (2013) 378-386.



ISSN (Print) : 2320 – 3765
ISSN (Online): 2278 – 8875

International Journal of Advanced Research in Electrical, Electronics and Instrumentation Engineering

An ISO 3297: 2007 Certified Organization

Vol. 5, Special Issue 2, March 2016

National Conference on Future Technologies in Power, Control and Communication Systems (NFTPCOS-16)

on 10, 11 and 12th March 2016

Organised by

Dept. of EEE, College of Engineering Perumon, Kollam, Kerala – 691601, India

- [3] Vijay Chand Ganti, Bhim Singh, Shiv Kumar Aggarwal, and Tara Chandra Kandpal “DFIG-based wind power Conversion with grid power levelling for reduced gusts,” IEEE Transactions, vol.3,no.1,January 2012
- [4] N.Suganthi, “Dynamic Modelling of Wind Turbines for System Frequency Control” International Journal of Electrical, Electronics and Data Communication, ISSN: 2320-2084, Volume- 1, Issue- 4.
- [5] Bhim Singh, and Gaurav Kumar Kasal “Voltage and frequency controller for a three-phase four-wire autonomous wind energy conversion system,”IEEE Transactions on energy conversion, vol. 23, no. 2, June 2008 .
- [6] Rakesh Sharma,Kuldeep Sahay,Sateyindra Singh,“Effects of Varying load on DC link voltage in DFIG based Wind energy conversion system”, IJAREEIE ,Vol.3,Issues, May 2014.