



# **Design and Implementation of a Power Conditioning Unit for Charging a Laptop using PV Cell Array**

L. Ramya Hyacinth<sup>1</sup>, R. Rithika<sup>2</sup>, S. Carmel<sup>2</sup>, V. Balameenakshi<sup>2</sup>

Assistant Professor, Dept. of EEE, Loyola-ICAM College of Engineering and Technology, Chennai, Tamilnadu, India<sup>1</sup>

IV Year, Dept. of EEE, Loyola-ICAM College of Engineering and Technology, Chennai, Tamilnadu, India<sup>2</sup>

**ABSTRACT:** In the future, more and more pressure will be given on renewable smart applications. One type of renewable energy is the solar energy. Many applications are covered with solar cell or module as the energy source. A Power Conditioning Unit (PCU) is designed for the photovoltaic (PV) cell array, which are a highly promising alternative for non-renewable energy generation due to their modularity and cleanness to make it compatible for charging a laptop. The Power Conditioning Unit comprises mainly of a DC to DC Boost Converter and a Microcontroller. The output from the PV cell array varies widely, whereas modern laptops require 18 V to 20 V. The maximum power required is either 90 W or 100 W. A boost converter is used to step up the output voltage of the PV cell Array whose voltage regulation is achieved using the Pulse Width Modulation. This paper uses ATmega8 Microcontroller, with an inbuilt ADC and PWM generator for PWM generation and PV Cell Switching. A MOSFET is switched using this PWM signal to regulate the output voltage.

**KEYWORDS:** Power Conditioning Unit, PV Cell Array, Boost Converter, Pulse Width Modulation, Modularity.

## **I. INTRODUCTION**

The worldwide demand for energy is increasing at an alarming rate. Among the sources of power, coal is the major contributor but also contributes to environmental pollution. The solution for this would be a source that does not contribute to pollution but balances the power requirement as well. Major advances have been made in recent years in improving the efficiency of almost all of the leading PV materials and devices. Basically, there are two approaches to increasing the efficiency of solar cells:

- (i) Selecting the semiconductor materials with appropriate energy gaps to match the solar spectrum and the optimizing their optical, electrical, and structural properties; and
- (ii) Innovative device engineering, which enables more effective charge collection as well as better utilization of the solar spectrum through single and multi-junction approaches.

However, the large number of applications in which PV cells can be implemented necessitates that a power electronic interface be present. This power electronic interface conditions the power suitable to the application and hence called as the Power Conditioning Unit (PCU).

## **II. SYSTEM MODEL AND ASSUMPTIONS**

This paper necessitates the design and implementation of a power conditioning unit for a PV cell array that is developed such that it can be used as a universal laptop charger. Thus the main objectives are:

- i) To design a DC-DC Converter.
- ii) To design the Control Module.
- iii) To design the Switching Circuitry.
- iv) To simulate and validate these designs.
- v) To implement these design in Hardware.

PV cell array is considered as the source of power. The output of the PV cell array is given to a PWM DC-DC converter. The PWM technique reduces the harmonic content. The output of the DC-DC converter is fed to the load. A

# International Journal of Advanced Research in Electrical, Electronics and Instrumentation Engineering

(An ISO 3297: 2007 Certified Organization)

Vol. 5, Special Issue 5, March 2016

sensing unit senses the load voltage and current requirements and accordingly the firing angle of the chopper present in DC-DC converter is varied using a microcontroller and accordingly the supply is limited.

The block diagram of the proposed system is shown in Fig 1.

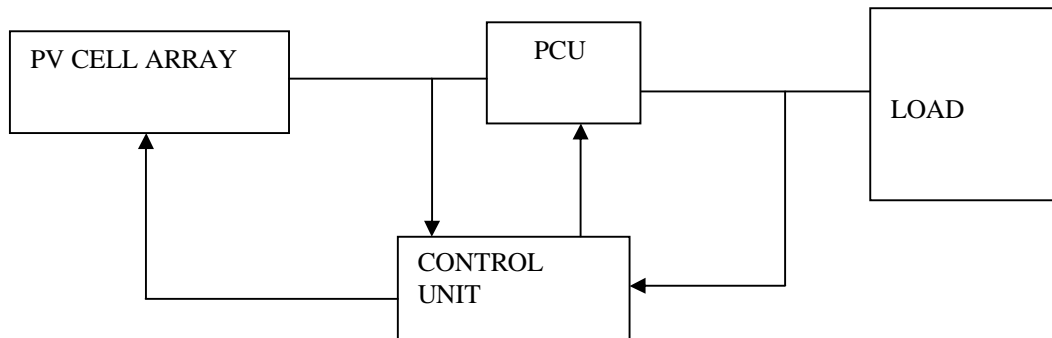

Fig.1 Block Diagram of the proposed system

The assumptions are:

1. The power MOSFET and the diode are ideal switches.
2. The transistor output capacitance, the diode capacitance, and lead inductances (And thus, the switching losses) are zero.
3. Passive components are linear, time-invariant, and frequency-independent.
4. The output impedance of the input voltage source V-I is zero for both DC and AC components.

### III. CONVERTER CIRCUIT DESCRIPTION AND SIMULATION

The PWM boost converter is operated in Continuous Current Mode as the DC voltage transfer function is independent of L. For the boost converter operating in CCM, the maximum efficiency occurs at full load  $I_{o,max}$  (or  $R_{L,min}$ ). The circuit of the PWM boost DC-DC converter is shown in Fig. 2. Its output voltage  $V_o$  is always higher than the input voltage  $V_i$  for steady-state operation [5]. It 'boosts' the voltage to a higher level. The converter consists of an inductor L, a power MOSFET, a diode D1, a filter capacitor C, and a load resistor  $R_L$  [6]. The switch S is turned on and off at the switching frequency  $f_s = 1/T$  with the ON duty ratio  $D = t_{on}/T$ , where  $t_{on}$  is the time interval when the switch S is ON.

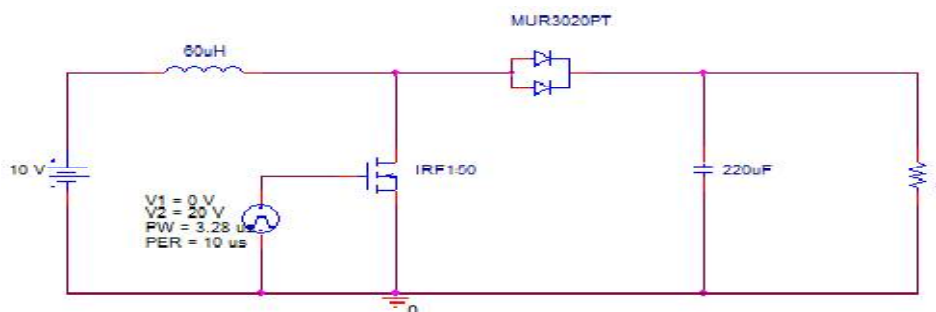

Fig. 2 PWM boost DC-DC converter

The boost converter can operate in either continuous or discontinuous conduction mode, depending on the waveform of the inductor current [6]. The voltage across the diode is  $V_D = -V_o$ , causing the diode to be reverse biased. The voltage across the inductor is  $V_L = V_i$ . As a result, the inductor current increases linearly with a slope of  $V_i/L$ . Consequently, the magnetic energy also increases. The switch current is equal to the inductor current [5].

# International Journal of Advanced Research in Electrical, Electronics and Instrumentation Engineering

(An ISO 3297: 2007 Certified Organization)

Vol. 5, Special Issue 5, March 2016

Before implementation of the hardware, all the designs are tested and validated using various simulation tools available. The simulation tools help in testing the validity of the design and also save cost by reducing the chances of error. Any defect in design can be easily identified and rectified well before the implementation thus saving cost and time. The DC-DC converter circuit is designed and tested using the PSpice simulation software. Fig. 3 shows waveforms of the input and output voltage that explain the principle of operation of the converter.

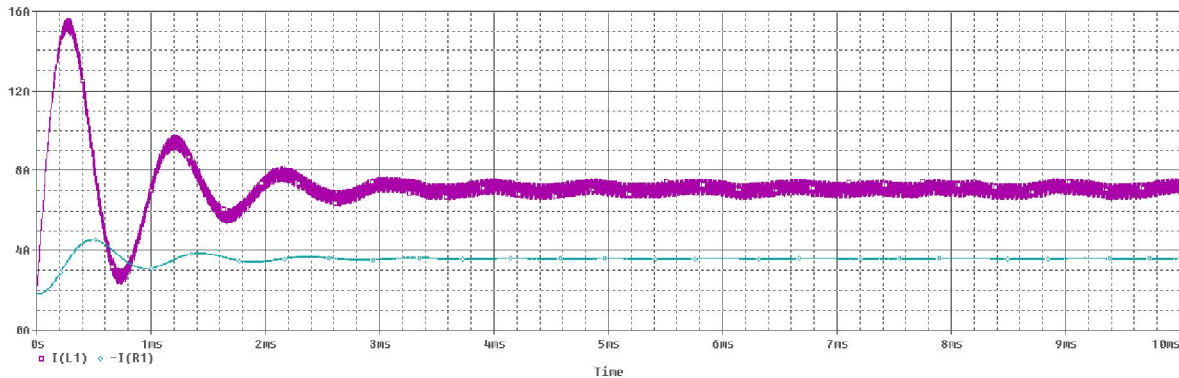

**Fig. 3 Input and Output Waveforms of boost converters**

Various components of the PCU are chosen based on its rating. Since the PCU is for laptop loads, the rated output voltage is between 18 V to 20 V. The laptop's rated voltage is 18.0 V, 18.5 V, 19.0 V, 19.5 V, or 20.0 V depending on the manufacturer and the model. So provision for adjusting the rated voltage is provided in the circuit. Thus, for the required DC-DC Converter to operate in CCM all values of D for  $V_o = 20$  V,

$$L = 55 \mu\text{H}$$

$$C = 220 \mu\text{F}$$

are selected. Using these and other designed values, various other component (power MOSFET and power Diodes) specifications are determined.

## IV. PWM GENERATION AND SWITCHING USING ATMEGA8

The ATmega8 has two 8-bit Timer/Counters and one 16-bit Timer/Counter. These Timer/Counters are used to generate signal of frequency 100 kHz. There are three PWM channels in the ATmega8. The 16-bit Timer/Counter1 has been used to generate the required PWM signal. Using the ADC and PWM modules of the ATmega8 the regulation of the output voltage can be achieved using the PWM technique. The microcontroller has to be programmed suitably. The ATmega8, belonging to the AVR series of microcontrollers from Atmel, can be easily programmed with the help of AVR studio and Win AVR compiler. The coding so developed is embedded into the microcontroller with the help of a programmer.

The control logic is shown in Fig. 4. The voltages  $V_{in}$ ,  $V_{ref}$ ,  $V_{temp}$ ,  $V_{sw}$  are sensed and stored in the microcontroller. If input is in the range 6 V to 17 V, the output  $V_o$  is sensed, else the PV cells are switched correspondingly. If output voltage is greater than 18 V, P is set 1. This is to ensure that power supply for the control module is derived from the converter itself. During starting till  $P = 1$  the power is derived from the battery. Then the sensed output voltage is compared with the reference voltage and the duty cycle is varied to make both of them equal. Then switching is done according switching reference input. Then this whole process is repeated in a cyclic manner. Thus the required regulated output voltage is obtained.

# International Journal of Advanced Research in Electrical, Electronics and Instrumentation Engineering

(An ISO 3297: 2007 Certified Organization)

Vol. 5, Special Issue 5, March 2016

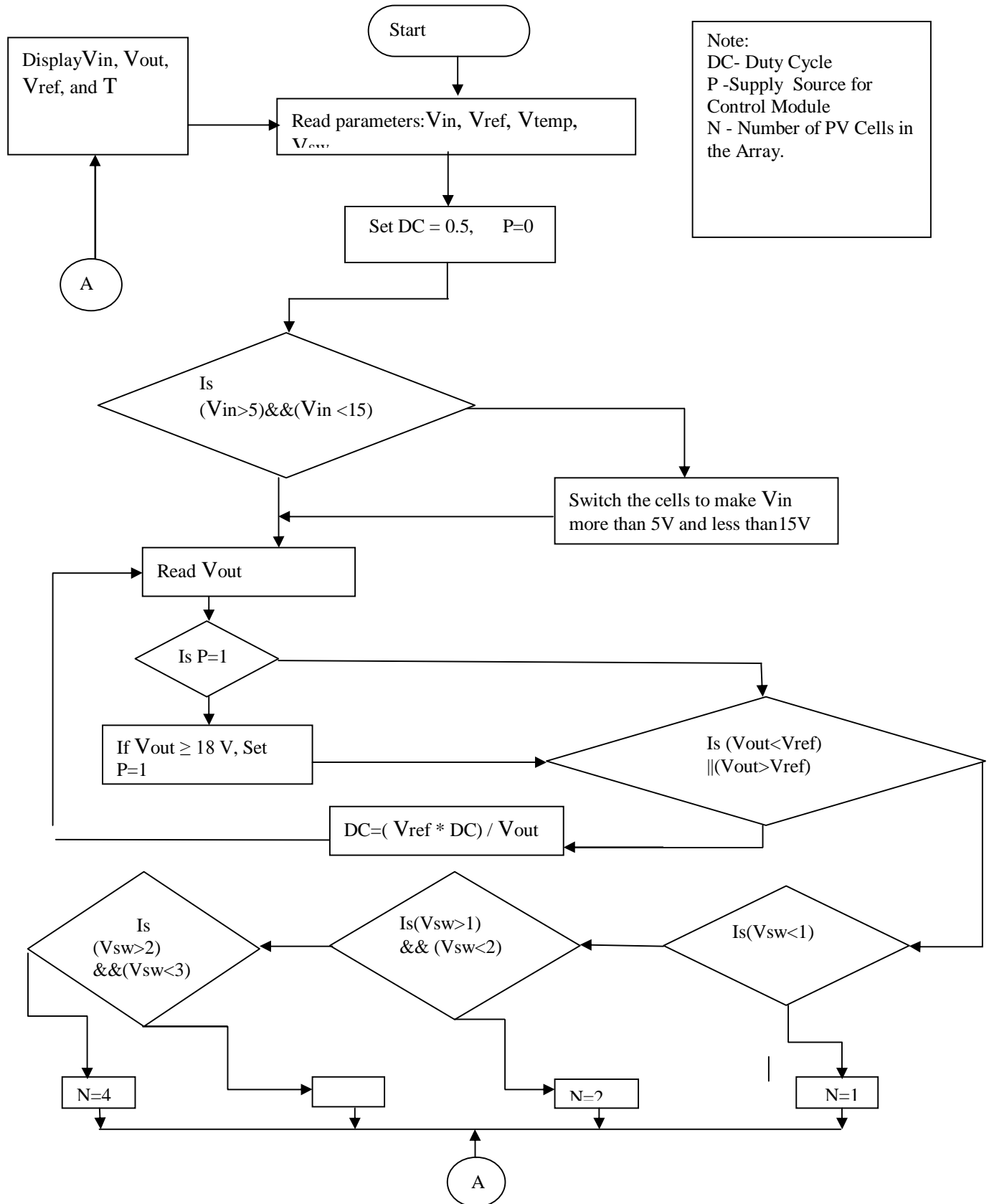



# International Journal of Advanced Research in Electrical, Electronics and Instrumentation Engineering

(An ISO 3297: 2007 Certified Organization)

Vol. 5, Special Issue 5, March 2016

## V. CONCLUSION

The proposed system based on ATmega8 microcontroller is found to be more compact, user friendly, and less complex. This is used to precisely regulate the output of the DC-DC Boost Converter to supply the required power to any laptop load which generally requires 18 V to 20 V DC. The Power Conditioning Unit, with ATmega8 as its brain, senses the output voltage of the DC-DC boost converter and varies the triggering PWM so that the DC-DC Boost Converter supplies the laptop load with its rated voltage at all times. The inbuilt ADC and PWM channels in the ATmega8 make the control module of the PCU very compact. This system also has a provision for varying the number of PV cells in the array by switching. The usage of PV cells as the source of power makes the system portable and hence it can be used in lot of applications. Future extension of this project can be made by making the switching automated. The number of PV cells to be included in the array can be decided based on the load variations. The same ATmega8 can be used for this purpose. Also, modifications in the inductor design can be done to make it more compact.

## REFERENCES

- [1] J. Zhao, A. Wang, M. Taouk, S. R. Wenham, M. A. Green, and D.L. King, "20% efficient photovoltaic module," IEEE Electron Devices Lett., vol. 14, pp. 539–541, 1993.
- [2] Satyen K. Deb, "Recent developments in high-efficiency PV cells," National Renewable Energy Laboratory Golden, CO 80401-3393 USA.
- [3] M. A. Green, SOLAR CELLS: Operating Principles, Technology and System Applications. Englewood Cliffs, NJ: Prentice Hall, 1982, (reprinted 1986, 1992), pp. 91–92.
- [4] Rohatgi A., Narasimha S., Kamra S., Doshi P., Khattack C.P., Emery K. and Field H. (1996b). Record high 18.6% efficient solar cell on HEM multocrystalline material. Proc 25th IEEE PVSEC, 741-744.
- [5] M.T. Outeiro, R. Chibante, A. S. Carvalho ; "A soft-switching DC/DC converter to improve performance of a fuel cell system", Industrial Electronics, IECON '09, 35th Annual Conference of IEEE, 2009.
- [6] Kazimierczuk, Marian K., 2008, "Pulse-width Modulated DC–DC Power Converters", John Wiley & Sons Ltd., United Kingdom, pp. 85-103.
- [7] Erickson Robert W., Dragan Makismovic, 2004, "Fundamentals of Power Electronics", Kluwer Academic Publishers, New York. pp. 11-179, pp. 491-564.
- [8] Rashid Muhammad H., 2007, "Power Electronics: Circuits, Devices and Applications" Prentice Hall of India Private limited, New Delhi, pp. 166-225.