



Power Flow Analysis of Distribution System

Tanveer Husain¹, Muqueem Khan², Mujtahid Ansari³

PG Student [EPS], Dept. of Electrical, SSBT's COET, Bambhori, Jalgaon, Maharashtra, India¹

PG Student [EPS], Dept. of Electrical, SSBT's COET, Bambhori, Jalgaon, Maharashtra, India²

Assistant Professor, Dept. of Electrical, SSBT's COET, Bambhori, Jalgaon, Maharashtra, India³

ABSTRACT: Power flow analysis is the backbone of power system analysis and design. They are necessary for planning, operation, economic scheduling and exchange of power between utilities. Power flow analysis is required for many other analyses such as transient stability, optimal power flow and contingency studies. The principal information of power flow analysis is to find the magnitude and phase angle of voltage at each bus and the real and reactive power flowing in each transmission lines. Power flow analysis is an importance tool involving numerical analysis applied to a power system. In this analysis, iterative techniques are used due to there no known analytical method to solve the problem. This resulted nonlinear set of equations or called power flow equations are generated. This paper presents anew and efficient method for solving the load flow problem of a distribution system. It is mainly based on network topology, basic circuit laws and power summation technique. The main contribution of this paper is: (i) proposing a new and efficient load flow method for radial and weakly meshed distribution systems, (ii) evaluating the impact of load models, different X/R ratios, load growth and tolerance levels, (iii) analysis of impact of number of loops on weakly meshed distribution systems, (iv) comparison of radial and weakly meshed distribution system. The results are obtained for voltage profile, total power losses time of computation, and number of iterations. Computer program coded to implement this power flow solution scheme in MATLAB and successfully applied to several practical distribution networks with radial and weakly meshed structure. Effectiveness of the proposed load flow method has been presented on IEEE 33bus and IEEE69 bus radial and meshed distribution networks.

KEYWORDS: Power Flow, MATLAB, Newton Raphson, Distribution System.

I. INTRODUCTION

Power flow analysis is a very important and basic tool in the field of power system engineering. It is used in the planning and design stages as well as during the operational stages of a power system. Some applications, especially in the fields of optimization of power system and distribution automation, need repeated fast power flow solutions. In these applications, it is imperative that the power flow analysis is solved as efficiently as possible. With the development of microcomputer, distribution-substation-owned computer programs have become a necessity. However, the choice of solution methods for the practical application is difficult. It requires a careful analysis of comparative merits and demerits of those methods available in respect of memory storage requirements, computation speed and convergence criterion.

A power flow method must be robust and time efficient to tackle the special features of distribution system, such as: high R/X ratios of the line data, radial or weakly meshed network structure, unbalanced distributed load and large number of nodes etc. Due to these reasons, the conventional Newton Raphson method and Fast De-coupled Load Flow method fail to converge to a solution [1-2]. Some efficient algorithms for solving the load flow problem of a radial distribution networks have been reported in the literature [3]-[7]. However, these algorithms are not suitable for a mesh network. Several load flow algorithms specially designed for meshed distribution systems have been reported in the literature [8-16].

Based on the previous work [8], a modified compensation based method was developed in [9], which uses active and reactive power as flow variables rather than complex currents. The compensation based method for weakly meshed networks presented in [8], was modified from single-phase system to three-phase system [10]. The mesh network is converted into radial network by breaking the loops and the load flow has been carried out by calculating power injections at the loop break points by using a reduced order bus impedance matrix [11].

International Journal of Advanced Research in Electrical, Electronics and Instrumentation Engineering

(An ISO 3297: 2007 Certified Organization)

Vol. 5, Issue 5, May 2016

II. PROPOSED POWER FLOW APPROACH FOR DISTRIBUTION SYSTEM

An efficient and simple load flow method is proposed for analysis of the radial and weakly meshed network based on network topology and basic circuit laws (KCL and KVL). Radial distribution systems have poorest service reliability. In radial distribution systems customers at far end of the substation suffers from major voltage drops and distributor near to substation gets heavily loaded. To improve reliability and provide better voltage regulation meshed distribution networks are used by closing the tie line switches. Some distribution feeders serving high density load areas contain loops created by closing tie line switches.

1. Simple Radial and Meshed Distribution System:

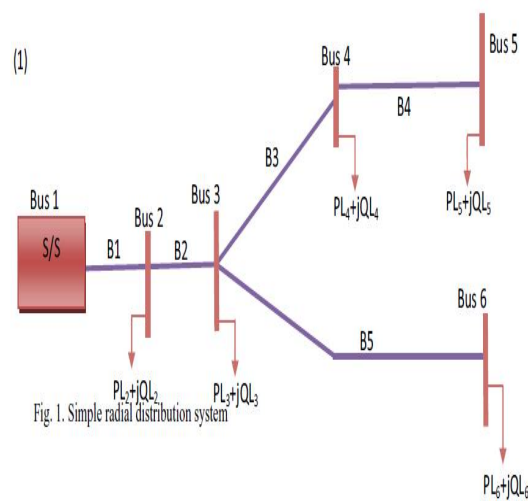

For radial system shown in fig1. , the effective powers at each node $P(1)+jQ(1)$, $P(2)+jQ(2)$, $P(3)+jQ(3)$, $P(4)+jQ(4)$, $P(5)+jQ(5)$, $P(6)+jQ(6)$.

$$P(1)+jQ(1) = PL_2 + jQL_2 + PL_3 + jQL_3 + PL_4 + jQL_4 + PL_5 + jQL_5 + PL_6 + jQL_6 + ploss(B1) + jqloss(B1) + ploss(B2) + jqloss(B2) + ploss(B3) + jqloss(B3) + ploss(B4) + jqloss(B4) + ploss(B5) + jqloss(B5) \quad (01)$$

$$P(2)+jQ(2) = PL_2 + jQL_2 + PL_3 + jQL_3 + PL_4 + jQL_4 + PL_5 + jQL_5 + PL_6 + jQL_6 + ploss(B2) + jqloss(B2) + ploss(B3) + jqloss(B3) + ploss(B4) + jqloss(B4) + ploss(B5) + jqloss(B5) \quad (02)$$

$$P(3)+jQ(3) = PL_3 + jQL_3 + PL_4 + jQL_4 + PL_5 + jQL_5 + PL_6 + jQL_6 + ploss(B3) + jqloss(B3) + ploss(B4) + jqloss(B4) + ploss(B5) + jqloss(B5) \quad (03)$$

$$P(4)+jQ(4) = PL_4 + jQL_4 + PL_5 + jQL_5 + ploss(B4) + jqloss(B4) \quad (04)$$

$$P(5)+jQ(5) = PL_5 + jQL_5 \quad (05)$$

$$P(6)+jQ(6) = PL_6 + jQL_6 \quad (06)$$

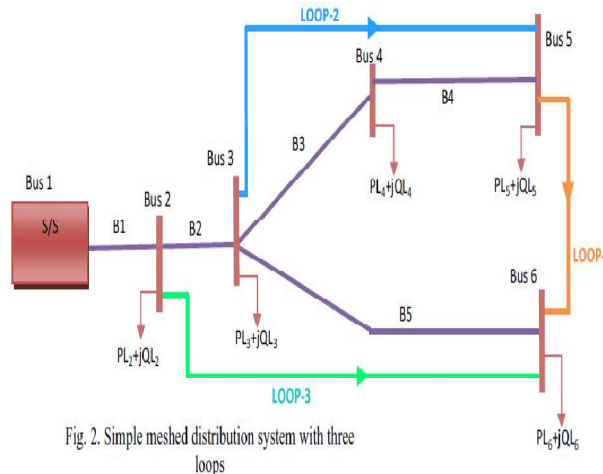

Similarly, for mesh distribution system shown in fig.2, In the presence of tie lines the effective power at receiving end of each branch is recalculated as:

$$P(1)' + jQ(1)' = P(1) + jQ(1) \quad (07)$$

$$P(2)' + jQ(2)' = P(2) + jQ(2) \quad (08)$$

$$P(3)' + jQ(3)' = P(3) + jQ(3) - \{ I_{loop(3)} * [V(3)] * \} \quad (09)$$

$$P(4)' + jQ(4)' = P(4) + jQ(4) + \{ I_{loop(1)} * [V(4)] * \} - \{ I_{loop(2)} * [V(4)] * \} \quad (10)$$

$$P(5)' + jQ(5)' = P(5) + jQ(5) + \{ I_{loop(1)} * [V(5)] * \} - \{ I_{loop(2)} * [V(5)] * \} \quad (11)$$

$$P(6)' + jQ(6)' = P(6) + jQ(6) - \{ I_{loop(1)} * [V(6)] * \} - \{ I_{loop(3)} * [V(6)] * \} \quad (12)$$

III. PERFORMANCE ANALYSIS

1. Algorithm and Flow Chart of Proposed Power Flow Method of Distribution System:

- Step 1: Read bus data and line data.
- Step 2: Initialize the bus voltages as $v(i) = 1.0$
- Step 3: Built the Basic loop incidence matrix (C).
- Step 4: Calculate the loop impedance matrix.
- Step 5: Calculate the effective real and reactive powers at receiving end node of the each branch in backward direction.
- Step 6: Calculate the voltage drops in each loop (VD_{loop} matrix).
- Step 7: Calculate the currents in each loop.
- Step 8: Modify the effective real and reactive powers at receiving end of each branch with the help of loop currents calculated in step 6.
- Step 9: Calculate voltage at receiving end and real and reactive power losses of each branch in the forward direction.
- Step 10: Calculate the real and reactive power losses in the tie line with the help of loop currents calculated in step 6.
- Step 11: Calculate the effective real and reactive power losses at each receiving end node of the branch in backward direction.
- Step 12: Update the effective power at each node.
- Step 13: Find the voltage mismatch ($delV$). Update the voltages.
- Step 14: Find error in voltage $i.e.$ $delV_{max}$. If it is less than 0.0001 then load flow is converged otherwise go to step 5.
- Step 15: Once load flow is converged bus voltages and power losses are known.

International Journal of Advanced Research in Electrical, Electronics and Instrumentation Engineering

(An ISO 3297: 2007 Certified Organization)

Vol. 5, Issue 5, May 2016

Step 16: Stop.

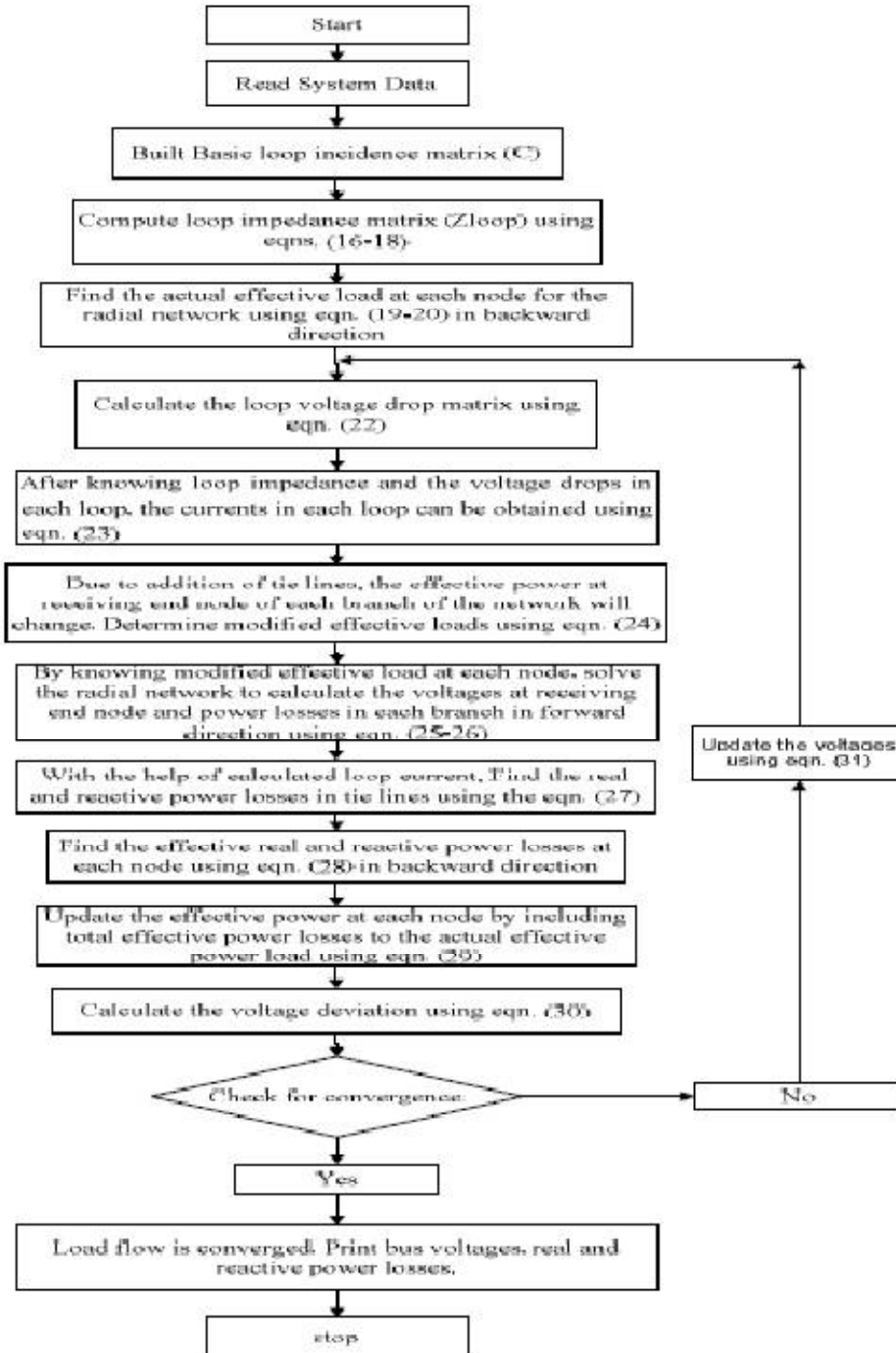

Fig.3 Flow chart of proposed power flow algorithm for meshed distribution network



International Journal of Advanced Research in Electrical, Electronics and Instrumentation Engineering

(An ISO 3297: 2007 Certified Organization)

Vol. 5, Issue 5, May 2016

2. Newton-Raphson Method:

The idea of the method is as follows: one starts with an initial guess which is reasonably close to the true root, then the function is approximated by its tangent line (which can be computed using the tools of calculus), and one computes the x -intercept of this tangent line (which is easily done with elementary algebra). This x -intercept will typically be a better approximation to the function's root than the original guess, and the method can be iterated.

Suppose $f : [a, b] \rightarrow \mathbf{R}$ is a differentiable function defined on the interval $[a, b]$ with values in the Real numbers \mathbf{R} . The formula for converging on the root can be easily derived. Suppose we have some current approximation x_n . Then we can derive the formula for a better approximation, x_{n+1} by referring to the diagram on the right. We know from the definition of the derivative at a given point that it is the slope of a tangent at that point.

That is

$$f'(X_n) = \frac{\Delta y}{\Delta x} = \frac{f(x_n) - 0}{x_n - x_{n+1}} \quad (13)$$

We start the process off with some arbitrary initial value x_0 . (The closer to the zero, the better. But, in the absence of any intuition about where the zero might lie, a "guess and check" method might narrow the possibilities to a reasonably small interval by appealing to the intermediate value theorem.) The method will usually converge, provided this initial guess is close enough to the unknown zero, and that $f'(x_0) \neq 0$. Furthermore, for a zero of multiplicity 1, the convergence is at least quadratic in a neighbourhood of the zero, which intuitively means that the number of correct digits roughly at least doubles in every step. More details can be found in the analysis section below.

The Householder's methods are similar but have higher order for even faster convergence. However, the extra computations required for each step can slow down the overall performance relative to Newton's method, particularly if f or its derivatives are computationally expensive to evaluate.

Newton-Raphson method is commonly used and introduced in most text books. This method is widely used for solving simultaneous nonlinear algebraic equations. A Newton-Raphson method is a successive approximation procedure based on an initial estimate of the one-dimensional equation given by series expansion.

IV. LOAD GROWTH

For future expansion and planning of the distribution systems, it is desirable that a system engineer must know the future estimate of the system solutions for planning and expansion or the efficient operation of distribution systems. The load growth (LG) pattern is essential to know for future planning and expansion of the distribution systems. In this paper work, load growth is modeled as:

$$Load_i = Load * (1 + r)^m \quad (14)$$

Where,

r = annual growth rate

m = plan period up to which feeder can take the load

In conventional load flow studies, it is presumed that active and reactive power demands are specified constant values, regardless of the amplitude of voltages in the same bus. In actual power systems operation, different categories and types of loads such as residential, industrial, and commercial loads are present. The nature of these types of loads is such that their active and reactive powers are dependent on the voltage and frequency of the system. Moreover, load characteristics have significant effects on load flow solutions and convergence ability. Common static load models for active and reactive power are expressed in a polynomial or an exponential form. The characteristic of the exponential load models can be given as:

$$P = P_0 \left(\frac{v}{v_0} \right)^{np} \quad (16)$$

$$Q = Q_0 \left(\frac{v}{v_0} \right)^{nq} \quad (15)$$



International Journal of Advanced Research in Electrical, Electronics and Instrumentation Engineering

(An ISO 3297: 2007 Certified Organization)

Vol. 5, Issue 5, May 2016

Where n_p and n_q stand for load exponents, P_0 and Q_0 stand for the values of the active and reactive powers at the nominal voltages. V and V_0 stand for load bus voltage and load nominal voltage, respectively.

In this paper, a realistic static load model is considered that represents the power-voltage relationship as a polynomial equation of voltage magnitude. It is usually referred to as the ZIP model, as it is made up of three different load models: constant impedance (CZ), constant current (CI) and constant power (CP). The real and reactive power characteristics of ZIP load model are given as:

$$P = P_0 \left[a_p \left(\frac{v}{v_0} \right)^2 + b_p \left(\frac{v}{v_0} \right) + c_p \right] \quad (16)$$

$$Q = Q_0 \left[a_q \left(\frac{v}{v_0} \right)^2 + b_q \left(\frac{v}{v_0} \right) + c_q \right] \quad (17)$$

Where, the sum of the ZIP load coefficients for both P, and Q loads is equal to 1.

$$a_p + b_p + c_p = 1,$$

$$a_q + b_q + c_q = 1$$

In this seminar work $a_p = a_q = 0.3$, $b_p = b_q = 0.2$, $c_p = c_q = 0.5$. P_0 and Q_0 are the real and reactive power consumed at a reference voltage V_0 .

V. RESULT AND DISCUSSION

R =	X =	P =	Q =	vb =	Plosskw =	Qlosskw =	voltage =
0.0762	0.0388	0	0	1.0000	16.8042	8.5661	1.0000
0.4074	0.2075	0.0010	0.0006	0.9960 + 0.0004i	71.3939	36.3631	0.9960
0.3025	0.1540	0.0009	0.0004	0.9770 + 0.0023i	27.6696	14.0918	0.9770
0.3150	0.1604	0.0012	0.0008	0.9668 + 0.0039i	26.0406	13.2629	0.9668
0.6769	0.5843	0.0006	0.0003	0.9568 + 0.0054i	53.2996	46.0108	0.9568
0.1547	0.5114	0.0006	0.0002	0.9318 + 0.0034i	2.6787	8.8546	0.9318
0.5879	0.1943	0.0020	0.0010	0.9271 - 0.0019i	6.7909	2.2442	0.9271
0.8512	0.6116	0.0020	0.0010	0.9205 - 0.0011i	5.8918	4.2329	0.9205
0.8628	0.6116	0.0006	0.0002	0.9119 - 0.0029i	5.0230	3.5604	0.9119
0.1625	0.0537	0.0006	0.0002	0.9040 - 0.0044i	0.7815	0.2584	0.9040
0.3094	0.1023	0.0004	0.0003	0.9028 - 0.0042i	1.2449	0.4116	0.9028
1.2132	0.9545	0.0006	0.0004	0.9008 - 0.0040i	3.7715	2.9674	0.9008
0.4476	0.5892	0.0006	0.0004	0.8924 - 0.0061i	1.0322	1.3586	0.8924
0.4884	0.4347	0.0012	0.0008	0.8893 - 0.0079i	0.5062	0.4505	0.8894
0.6168	0.4504	0.0006	0.0001	0.8874 - 0.0087i	0.3993	0.2916	0.8874
1.0653	1.4223	0.0006	0.0002	0.8855 - 0.0093i	0.3571	0.4768	0.8856
0.6050	0.4744	0.0006	0.0002	0.8828 - 0.0110i	0.0754	0.0591	0.8828
0.1355	0.1293	0.0009	0.0004	0.8819 - 0.0112i	0.2142	0.2044	0.8820
1.2431	1.1202	0.0009	0.0004	0.9953 + 0.0001i	1.1081	0.9985	0.9953
0.3384	0.3954	0.0009	0.0004	0.9906 - 0.0015i	0.1342	0.1568	0.9906
0.5859	0.7746	0.0009	0.0004	0.9896 - 0.0019i	0.0581	0.0769	0.9896
0.3729	0.2548	0.0009	0.0004	0.9888 - 0.0024i	4.2998	2.9380	0.9888
0.7421	0.5860	0.0009	0.0005	0.9722 + 0.0016i	6.9559	5.4927	0.9722
0.7405	0.5794	0.0042	0.0020	0.9632 - 0.0004i	1.7431	1.3640	0.9632
0.1678	0.0855	0.0042	0.0020	0.9588 - 0.0014i	3.6496	1.8590	0.9588
0.2349	0.1196	0.0006	0.0003	0.9291 + 0.0043i	4.6773	2.3814	0.9292
0.8752	0.7717	0.0006	0.0003	0.9257 + 0.0056i	15.8975	14.0165	0.9257
0.6646	0.5790	0.0006	0.0002	0.9101 + 0.0077i	11.0276	9.6070	0.9101
0.4194	0.2136	0.0012	0.0007	0.8989 + 0.0096i	5.4873	2.7950	0.8989
0.8053	0.7959	0.0020	0.0060	0.8941 + 0.0120i	2.2543	2.2279	0.8941
0.2566	0.2991	0.0015	0.0007	0.8883 + 0.0102i	0.3017	0.3516	0.8884
0.2818	0.4382	0.0021	0.0010	0.8871 + 0.0097i	0.0186	0.0290	0.8871
		0.0006	0.0004	0.8867 + 0.0095i			0.8867

Table: Results of 33 bus Load Flow Distribution System

International Journal of Advanced Research in Electrical, Electronics and Instrumentation Engineering

(An ISO 3297: 2007 Certified Organization)

Vol. 5, Issue 5, May 2016

Load flow analysis is performed with existing method as well as proposed method for both radial and meshed distribution systems. The comparison of results corresponding to voltage profile, total real power loss (TPL) in kW and total reactive power loss (TQL) in kVAR, iterations (ITER) and cpu time in seconds is obtained. The proposed load flow method has been evaluated on two IEEE benchmark distribution systems and the results are presented for IEEE 33 and 69 bus test systems. Two IEEE test systems 33-bus [18] and 69-bus [19] are taken for analysis of balanced radial and meshed distribution systems. The popular voltage dependent load models, load growth, different R/X ratios and different loading conditions have been considered to study the impact on convergence ability. The effect of the loops has also been incorporated to observe the impact on the system performance. The voltage profile, total power losses, number of iterations and impact of load models, load growth and increase in R and X on CP load model are given

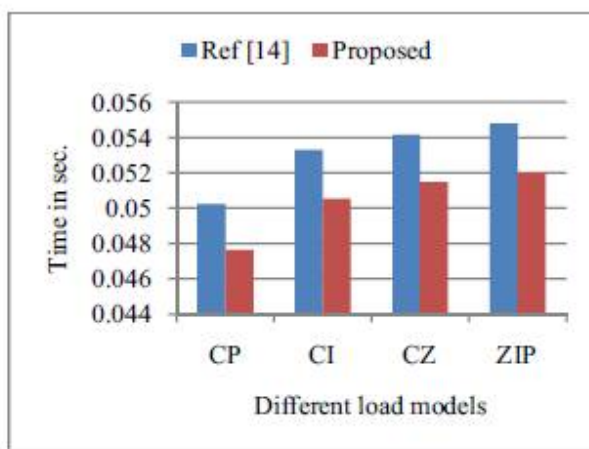

Fig. 4. Execution time plot for 33 bus meshed distribution system

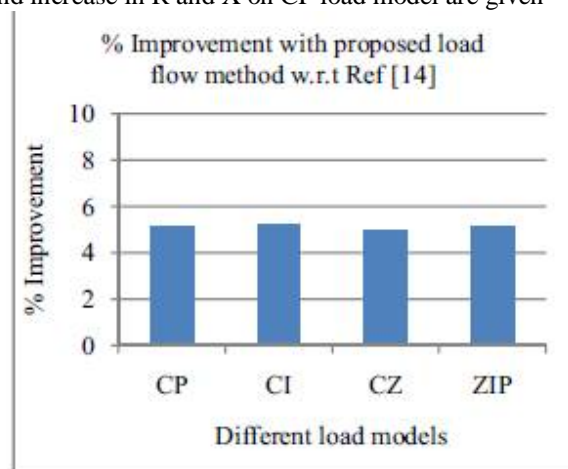

Fig. 5. Percentage improvement in time for 33 bus mesh distribution system

VI.CONCLUSION

In this paper, a new and efficient method for solving the load flow problem of a distribution system is proposed. The proposed method is compared with existing methods and it has been shown to be superior in the number of iterations, computationally efficient, and the robustness of convergence while the solution accuracy is well maintained. The proposed load flow approach is in close agreement with the existing methods. The proposed load flow method has been tested on two IEEE benchmark distribution systems under different loading conditions, different R/X ratio, different static load models, and considering load growth also. Load flow problem under different load conditions and for various ratios R/X has been determined with the proposed to check its convergence. It can be observed that the proposed method converges with varying load conditions and R/X ratios. It has been found from the cases that the method has good and fast convergence characteristics. Because of distinctive solution techniques of the proposed method, the time intensiveness due to LU decomposition and forward/backward substitution of the Jacobian matrix or admittance matrix required in the traditional load flow methods and formation BIBC and BCBV matrices, tree labeling, breaking the loops and injecting power injections are not necessary. Test results show that the proposed method is faster and converges with load variations and different R/X ratios and is suitable for large-scale distribution systems.

REFERENCES

- [1] Tinney W. G., and Hart C. E., "Power flow solutions by Newton's method," IEEE Trans. Power Apparatus Syst., Vol. 86, pp. 1449–1457, 1967.
- [2] Stott B., and Alsac O., "Fast decoupled load flow," IEEE Trans. Power Apparatus Syst., Vol. 93, No. 3, pp. 859–869, 1974.
- [3] Das D., Kothari D. P., and Kalam A., "Simple and efficient method for load flow solution of radial distribution networks", Elect. Power Energy Syst., vol. 17, no. 5, pp.335–46, 1995.
- [4] Ghosh S., Das D., "Method for load-flow solution of radial distribution networks", IEE Proc. Gen. Trans. Dist. Vol. 146, no. 6, pp. 641–648, 1999.
- [5] Hamouda A., and Zehar K., "Improved algorithm for radial distribution networks load flow solution" Elect. Power Energy Syst., vol. 33, Issue 3, pp. 508–514, 2011.



ISSN (Print) : 2320 – 3765
ISSN (Online): 2278 – 8875

International Journal of Advanced Research in Electrical, Electronics and Instrumentation Engineering

(An ISO 3297: 2007 Certified Organization)

Vol. 5, Issue 5, May 2016

- [6] Thukaram D., Banda H. M. W., and Jerome J., “A robust three-phase power flow algorithm for radial distribution systems,” *Elect. Power Syst. Res.*, Vol. 50, No. 3, pp. 227–236, 1999.
- [7] Ranjan R., Venkatesh B., Chaturvedi A., and Das D., “Power flow solution of three-phase unbalanced radial distribution network,” *Elect. Power Compon. Syst.*, Vol. 32, No. 4, pp. 421–433, 2004.
- [8] Shirmohammadi D., and Hong H. W., Semlyen A., and Luo G. X., “A compensation-based power flow method for weakly meshed distribution and transmission networks,”
- [9] Luo G. X., and Semlyen A., “Efficient load flow for large weakly meshed networks”, *IEEE Trans. Power Syst.*, Vol. 5, no. 4, pp. 1309–1316, 1990.
- [10] Cheng C.S, and Shirmohammadi D, “A three phase power flow method for real time distribution system analysis,” *IEEE Trans. Power Syst.*, Vol.10, No.2, pp.671-679, 1995.
- [11] Haque M. H., “Efficient load flow method for distribution systems with radial or mesh configuration,” *IEE Proc. Generat. Transm. Distrib.*, Vol. 143, No. 1, pp. 33–38, 1996.
- [12] Haque M. H., “A general load flow method for distribution systems”, *Elect. Power Syst. Res.*, vol. 54, pp. 47–54, 2000.
- [13] Chang G., Chu S. Y., Hsu M. F., Chuang C. S., and Wang H. L., “An efficient power flow algorithm for weakly meshed distribution system” *Elect. Power Syst. Res.*, vol. 84, issue. 1, pp. 90-99, 2012.
- [14] Teng J. H., “A Direct Approach for Distribution System Load Flow Solutions”, *IEEE Trans. on Power delivery*, vol. 18, no. 3, pp.882-887, 2003.
- [15] Lin W. M., and Teng J. H., “Phase-decoupled load flow method for radial and weakly-meshed distribution networks” *IEE Proc. Generat. Transm. Distrib.*, Vol. 143, No. 1, pp. 39–42, 1996.
- [16] Eminoglu U., Hocaoglu M. H., “A new power flow method for radial distribution systems including voltage dependent load models”, *Elect. Power Syst. Res.*, vol. 76, no. 2, pp. 106–14, 2005.
- [17] Kashem M. A., Ganapathy V., Jasmon G. B., and Buhari M. I., “A Novel Method for Loss Minimization in Distribution Networks” *IEEE DRPT*, pp. 251-256, 2000.
- [18] Sivanagaraju S., Visali N., Sankar V., And Ramana T., “Enhancing Voltage Stability of Radial Distribution Systems by Network Reconfiguration”, *Elect. Power Comp. and Syst.*, Vol. 33, No. 5, pp. 539-550, 2005.