



Enhancing throughput in MC-CDMA Systems Using Non Contiguous Spectrum

N.C.A. Boovarahan¹, Dr.K.Umapathy²

Research Scholar, SCSVMV University, Enathur, Tamilnadu, India

Associate Professor, SCSVMV University, Enathur, Tamilnadu, India

ABSTRACT : In this paper by varying the number of bits to the respective channels with the range of SNR. With the prediction of channel conditions on the time of next timeslot, all these work done on the spectrum of non contiguous spectrum allocation scheme by using adaptive sub channel grouping (ASG) modulation schemes for the sub carriers with maintaining BER to improve the throughput in the adaptive subchannel grouping technique. By analyzing the LTE standards of 3GPP candidate of 4G with two switching levels of modulations i.e. 8PSK and 128 QAM. By increasing the number of users starting from 64 QAM to QPSK. For the simulation Rayleigh fading channel and auto regressive model used. By improving the system throughput as compared to contiguous schemes of group formation. The result of this paper shows significant improvement of non contiguous spectrum allocation scheme is better than the contiguous spectrum allocation scheme.

KEYWORDS : MC-CDMA, ASG , QAM , QPSK , LTE.

I. INTRODUCTION

To achieve high transmission data rates in the 4G systems, large amount of bandwidth transmission was expected. In 4G system should provide additional capabilities it was defined by International Telecommunication Union (Geneva). Many user friendly applications are amended like HD TV, Smart phones , Wireless modems etc. Mobile WIMAX standard it was first used in south korea in the year of 2007 it is one of the 4G candidate systems and the other Long term evolution standard deployed commercially. IMT Advanced is the next development standard in the 4G[1]. In the Release 10 LTE advanced is standardized by the 3GPP of Universal Mobile Telecommunication System and Long term Evolution. 1Gbit/s and 500Mbit/s are the targets for downlink and uplink peak data requirements respectively under 100 Mhz spectrum allocation[2].

To reduce Multiple access interference (MAI)and Intersymbol Interference (ISI) 4G wireless communication demands a multiple access technique and improvement of Bit error rate is needed. These factors coming under to support the time varying QoS in the multiuser environment for 4G Multi carrier CDMA systems. Multipath fading and high spectral efficiency resisted by MC-CDMA technology.

Orthogonal Frequency division Multiplexing (OFDM) is one of the fusion of two techniques in the MC CDMA technology which used to addresses the intersymbol interference problem arising in the channels, the other technique is used to maintain orthogonality with the users to eliminate the multiple access interference called CDMA.

International Journal of Advanced Research in Electrical, Electronics and Instrumentation Engineering

(An ISO 3297: 2007 Certified Organization)

Vol. 5, Issue 7, July 2016

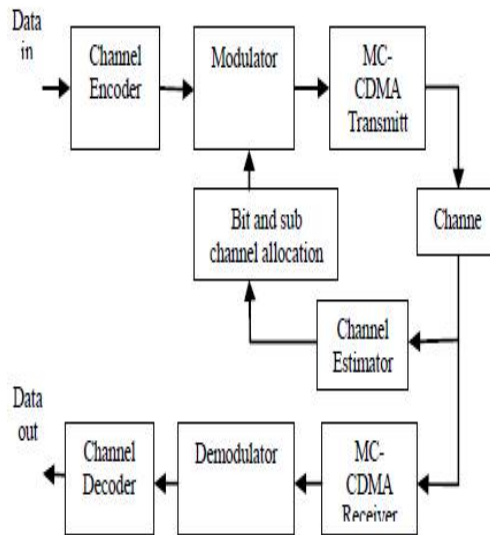

Figure1. MC-CDMA system

II. MAXIMUM THROUGHPUT FORMULATION

The concept of maximum throughput formulation is to maintain low Bit Error Rate and maximizing throughput while allocating maximum channels to maximum users at base station under given transmit power in the downlink of MC CDMA transmission.

By increasing the system capacity, available sub carriers converted into groups, and then groups allocated to users. All the channels of single group allocated to one user and available transmit power equally distributed to all the channels within group. Formation of groups can be done by contiguous or non contiguous sub carrier grouping. The required amount of transmit power of every group contains one sub carrier is determined for all users before allocating the groups can be given by throughput maximization problem C_g^u problem as given in Ref [2],

$$\text{Max } \sum_{u=1}^U \sum_{g=1}^G C_g^u \text{ ----- (1)}$$

Where

C_g^u - number of the u^{th} user's channels on the g^{th} group

U – Total number of users

G – Total number of groups of sub carriers.

Problem (1) is subject to,

$$\sum_{u=1}^U \text{sgn}(C_g^u) \leq 1, \forall u, g \text{ ----- (1 a)}$$

$$\sum_{u=1}^U \sum_{g=1}^G C_g^u P_g^u \leq P_T^{\text{max}} \text{ ----- (1 b)}$$

$$C_g^u \in \{0, 1, \dots, S\}, \forall u, g \text{ ----- (1 c)}$$

Where

S - Total number of subcarriers in g^{th} group

Above "(1 b)" is the total transmit power constraint

Where

P_T^{max} -- The maximum transmit power, and

P_g^u -- The required transmit power for u^{th} user on one channel of the g^{th} group, it is expressed as,

International Journal of Advanced Research in Electrical, Electronics and Instrumentation Engineering

(An ISO 3297: 2007 Certified Organization)

Vol. 5, Issue 7, July 2016

$$p_g^u = \sum_{s=1}^S (\beta N_o S^{-2} \sum_{s=1}^S |\omega_{g,s}^u|^2 \sum_{s=1}^S |\omega_{g,s}^u f_{g,s}^u|^{-2}) \quad \text{-----(2)}$$

Where

β -Target threshold of SNR, calculated as using following relation in the upcoming equation

$$BER_i = \frac{1}{5} \times \exp \left[\frac{-1.5 \times \beta}{M - 1} \right] \quad \text{----- (3)}$$

BER_i -- Bit error rate of i^{th} subcarrier

$M = 4$, as modulation scheme used is QPSK.

$f_{g,s}^u$ -- u^{th} user's channel fading (path gain) on the s^{th} subcarrier of the desired group.

$\omega_{g,s}^u$ -- u^{th} user's frequency domain combining weight for the signal on the s^{th} sub carrier of the desired group.

Fading problem arises for every user on different channels so every user needs different transmit power on different channels, so the channel allocation to the users according to their requirement of transmit power.

For different combining schemes throughput will be different as per Table I, Ref [2].

Combining Schemes	P_g^u
MRC	$\sum_{s=1}^S (\beta N_o S^{-2} \sum_{s=1}^S f_{g,s}^u ^2 \sum_{s=1}^S f_{g,s}^u ^{-4})$
EGC	$\sum_{s=1}^S (\beta N_o S^{-1} \sum_{s=1}^S f_{g,s}^u ^{-2})$
ZFC	$\sum_{s=1}^S (\beta N_o S^{-1} \sum_{s=1}^S f_{g,s}^u ^{-2})$

Table 1 : Required Power For Combining Schemes.

III. SUBCHANNEL SELECTION ALGORITHM

Downlink transmission of multi user MC-CDMA systems for the channel allocation, non contiguous spectrum allocation technique

proposed[1] with maintained power and the bit error rate including signal to noise ratio. In this survey paper uses the new technique of subcarrier group formation with CSI for MCCDMA systems[1] and follows channels in one group are not using neighboring bands & each group the number of channels existing is different.

The required transmit power decreases and more number of channels allocated for given transmit power at base station, it results in improved throughput.

International Journal of Advanced Research in Electrical, Electronics and Instrumentation Engineering

(An ISO 3297: 2007 Certified Organization)

Vol. 5, Issue 7, July 2016

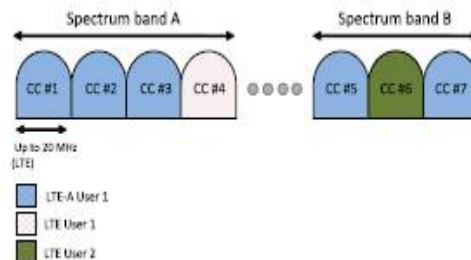

Figure 2: Non-contiguous sub-carrier grouping in MC-CDMA

From the figure 5 spectrum bands are considered as sub-carriers, in the figure shown only two sub carriers but our case increased upto 'N' subcarriers , (that is N number of channels) and that channels divided into 'G' groups depends on the user s fading on a particular channel, where the user s faces the minimum fading on the channel , all the channels assigned to the users randomly, and the group forms depends on the assigned channels to the user. Starting from 1st channel , it scans all the users and user facing minimum fading on it, will be allotted that 1st channel. Likewise the second channel too.[2]

Initialization

$$P_R = P_T^{max}, \quad \% P_R = \text{Residual transmit power.}$$

$$C = \{1, 2, \dots, G\}, \quad c_g^u = 0 \text{ for}$$

$$u = 1, \dots, U \text{ and } g = 1, \dots, G.$$

Formation of Groups to user

For $c = 1 \dots N$

$$g_u = \max_{1 \leq u \leq U} \{f_c^u\}$$

End

N – Total no. of subcarriers.

f_c^u – uth user's channel fading (path gain) on the cth subcarrier.

g_u – uth user's group of subcarriers.

Like this to scan all users (U), allocation of the channels to users randomly depends on users fading experiences, that allocated channels to single user forms one group of channels.

Therefore no. of groups equals to no. of users.

$$G = U$$

After this the required amount of transmit power to each group from eqn (2) has been done.

Which group having lower transmit power requirement has been selected ($\min\{P_g^u\}$)

After that allocate the channels within group[2] as given below,

Channel allocation

While C not equal to 0

$$t = \arg \min_{v_g \in C} \{P_g^{u_{gmin}}\}; \quad \% \text{ select group with lower transmit power requirement}$$

$$c_t^{u_{gmin}} = \min \left(\left\lfloor \frac{P_R}{P_t^{u_{gmin}}} \right\rfloor, S \right); \quad \% \text{ calculate the available channel number}$$

$$P_R = P_R - c_t^{u_{gmin}} P_t^{u_{gmin}}; \quad \% \text{ calculate the residual transmit power}$$

$$C = C \setminus \{u_{gmin}\};$$

If $c_t^{u_{gmin}} = 0$ %since the residual transmit power is not enough, terminate channel allocation.

Break the loop;

End If End While



International Journal of Advanced Research in Electrical, Electronics and Instrumentation Engineering

(An ISO 3297: 2007 Certified Organization)

Vol. 5, Issue 7, July 2016

IV. SURVEY REPORT

- 1) Hema Kale, C.G. Dethé and M.M. Mushrif 2014 says in the title of Non Contiguous Spectrum allocation in MC-CDMA systems for improving throughput has Adaptive sub channel grouping (ASG) scheme is carried out. They found these scheme employing non contiguous spectrum allocation can significantly improve system throughput is compared with continuous schemes of group formation. They concluded with ASG algorithm suits for medium and high values of transmit power & allocate all channels with groups of users with low transmit power compared with existing algorithm in the non contiguous spectrum allocation.
- 2) Jun-Bo Wang b, Ming Chen a, Jiangzhou Wang a 2009 says in the title of Adaptive Channel and power allocation of downlink multiuser MC-CDMA systems has In these paper they proposed adaptive channel allocation algorithm for maximizing throughput in which sub channels were divided into groups They concluded the improvement in the throughput by allocated the channels in the contiguous spectrum allocation and saving power for higher throughput in the MC-CDMA systems.
- 3) Hema Kale, C.G. Dethé and M.M.Mushrif 2012 says in the title of Improved Algorithm for Throughput maximization in MC-CDMA has In these paper they proposed improved algorithm for the maximization of the throughput in the MC-CDMA systems.They given group assignment technique such that the power and channel utilized properly and maximum number of channels allocated to the users.
- 4) Muhammad Safdar, Muhammad Aqueel Ashraf, Imran Mehmood 2015 says in the title of Extension of SAFNAQ Algorithm for MC-CDMA using Channel Allocation says In these paper they incorporated into SAFNAQ algorithm to improve BER performance of MC-CDMA systems. Simulation results of this paper shows uasage of adaptive sub-channel allocation along with SAFNAQ algorithm improves overall Bit error rate (BER) Performance.
- 5) Hema Kale, C.G.Dethé & M.M.Mushrif 2012 says in the title of A review of sub-carrier selection techniques employed in MC-CDMA systems for 4G Networks has Various types of Sub Carrier Selection techniques were discussed and allocation of the sub carriers with ACA algorithm has to be putforth. Single channel and group channel allocation of the spectrum division had been done in these paper.
- 6) G.K.D. Prasanna Venkatesan and V.C.Ravichandran 2007 says in the title of Performance analysis of dynamic sub-carrier allocation technique for adaptive modulation based MC-CDMA system has Eliminating transmission on poor subcarrier can considerably improve BER performance of the system and higher order modulation utilized on respective subcarriers for throughput maximization. Analyzation of performance characteristics in proposed system of frequency sleective fading environment with narrowband interference existing has been carried out in these paper. Results shows proposed adaptive MC-CDMA outperforms conventional MRC MC-CDMA system.
- 7) Teruya Fujii, Noburu Izuka, Hiroyoshi Masui, and Atsushi Nagate 2005 says in the title of A proposal of sub carrier selecting MC-CDMA system for 4G systems has Selected number of sub carriers in the SCS-MC-CDMA assigned to each users to be put forth. Sub carriers assigned to users has been done and they counter the problem of high power consumption issue also resolved in these paper.
- 8) S.Chatterjee, W.A.C. Fernando, M.K. Wasantha 2003 says in the title of Adaptive Modulation based MC-CDMA Systems for 4G Wireless Consumer Applications has For high data rate achievement , adaptive modulation based M-ary PSK, M-ary QAM, M-ary CPM, M-ary MHPM and GMSK systems applied to Turbo coded MC-CDMA system in Rayleigh fast fadiing channel environment had been investigated and BER performance of all these techniques had been compared. They found the system using M-ary MHPM as the modulation scheme performs best among the considered modulation schemes.
- 9) Qingxin Chen, Elvino S. Sousa & Subbarayan Pasupathy 1996 says in the title of Multicarrier CDMA with adaptive frequency hopping for mobile radio systems has The problem of determining the optimal hopping pattern is formulated as a multiobjective optimization problem, for which an efficient algorithm, based Water-filling principle, was designed to solve the practical problems so they designed MC DS CDMA system had been proposed. They showed the performance improvement over existing systems in terms of average system Bit Error rate Probability. That improvement can be directly translated into increase in CDMA system capacity.

V. CONCLUSION

In this paper shows the survey report of ASG scheme's Performance under non contiguous spectrum allocation in order to enhance the throughput technique in downlink MC-CDMA system & and the evaluation of Rayleigh and AWGN channel models and MRC,EGC, ZFC combining schemes are used and Bit Error Rate performance of Adaptive



ISSN (Print) : 2320 – 3765
ISSN (Online): 2278 – 8875

International Journal of Advanced Research in Electrical, Electronics and Instrumentation Engineering

(An ISO 3297: 2007 Certified Organization)

Vol. 5, Issue 7, July 2016

Subchannel Grouping (ASG) studied in detail. Finally the Survey report shows that ASG algorithm is suitable for Allocating the channels with less transmit power and compared with existing algorithms.

REFERENCES

- [1] Hema R. Kale, C.G.Dethe and Milind M. Mushrif, “Non Contiguous Spectrum allocation in MC-CDMA systems for improving throughput” in *International journal on communications ACEEE* Vol 5, 2014.
- [2] Jun-Bo Wang b, Ming Chen a, Jiangzhou Wang a, “Adaptive Channel and power allocation of downlink multi-user MC-CDMA systems” in *Computers and Electrical Engineering* 35 (Elsevier Journal) 622-633. (2009)
- [3] Muhammad Safdar, Muhammad Aqueel Ashraf, Imran Mehmood, “Extension of SAFNAQ Algorithm for MC-CDMA using Channel Allocation” in *International Bhurban Conference on Applied Sciences & Technology(IBCAS)* Islamabad, Pakistan, 13-17th January, 2015 IEEE.
- [4] Hema Kale, C.G. Dethe and Milind M. Mushrif, “Adaptive Sub Channel Grouping in MC-CDMA systems for 4G networks” proc. IEEE *International conference on Advanced Networks and Telecommunication systems(ANTS)*, 16-19 December 2012, Bangalore, India.
- [5] Teruyu Fujii, Noboru Izuka, Hiroyoshi Masui, and Atsushi Nagate, “A proposal of sub-carrier selecting MC-CDMA system for 4G systems” , 0-7803-9152-7/05/\$20.00© 2005.IEEE
- [6] G.K.D.Prasanna Venkatesan, and V.C.Ravichandran, “Performance analysis of dynamic sub-carrier allocation technique for adaptive modulation based MC-CDMA system” , *JCSNS International Journal of Computer Science and Network Security*, Vol.7 No.2, February 2007.
- [7] Qingxin Chen, Elvino S. Sousa and Subbarayan Pasupathy , “Multicarrier CDMA with adaptive frequency hopping for mobile radio systems” , in IEEE journal on selected areas in communications, vol. 14, no 9, december 1996.
- [8] Hema Kale¹, C.G. Dethe² and M.M. Mushrif³,—Improved Algorithm for Throughput Maximization in MC-CDMA, *International Journal of VLSI design & Communication Systems (VLSICS)*, Vol.3, No.4, August 2012.ISSN:0976-357(Online),0976-1527(Print).
- [9] S. Chatterjee¹, W.A.C. Fernando, M.K. Wasantha —Adaptive Modulation based MC-CDMA Systems for 4G Wireless Consumer Applications, *IEEE Transactions on Consumer Electronics*, Vol. 49, No. 4, November 2003.
- [10] Dhananjay Kumar, C. Chellappan, —Efficient resource allocation in MCCDMA cellular wireless networks to support multimedia traffic, *Journal of Theoretical and Applied Information Technology* 2009.
- [11] Jun-Bo Wang, Hua-Min Chen, Ming Chen, and Xinhua Xue, —Adaptive Subcarrier Grouping for Downlink MC-CDMA Systems with MMSE Receiver, *2010 IEEE*.
- [12] Jianli Xie¹, Cuiran Li¹, Chengshu Li², —Analysis of multicarrier CDMA system with adaptive subcarrier and power allocation, *IEEE Proceedings of IWSDA'07*, 2007.
- [13] M. Tabulo and et. al, LA linear programming algorithm for a grouped MC-CDMA system, *Proc. IEEE VTC'03*, vol. 3, pp. 1463-1467, Oct. 2003.
- [14] Ian F.Akyildiz, David M.Gutierrez-Estevez, Elias Chavarria Reyes, “The evolution to 4G cellular systems : LTE-Advanced” in *Physical Communication of* <http://www.elsevier.com/locate/phycom> ELSEVIER Journal pg no : 217-244 2010.
- [15] Jolly Parikh, Anuradha Basu, —LTE Advanced: The 4G Mobile Broadband Technology, *International Journal of Computer Applications* (0975 – 8887) Volume 13– No.5, January 2011.