

A Review on PAPR Reduction Techniques in OFDM System

Amit Nayak¹, Anjana Goen²

PG Student, Dept. of ECE, Rustamji Institute of Technology BSF Academy Tekanpur, Gwalior, M.P, India¹

Associate Professor, Dept. of ECE, Rustamji Institute of Technology BSF Academy Tekanpur, Gwalior, M.P, India²

ABSTRACT: In this paper we have focus to learn the basics of an OFDM communication System and have undertaken various methods to reduce the PAPR in the communication system [1]. So that this communication system can be used more commonly and effectively [4]. Signals were initially sent in the analog form now days in the digital form. For better transmission, single carrier waves are replaced by multi carriers system like CDMA and OFDM [3]. In the OFDM system, orthogonally placed sub carriers are used to send the data from the transmitter to the receiver. Presence of guard band in this system operates with the problem of ISI and noise is minimized by larger number of sub carriers in communication system. But the large PAPR of these signal have some undesirable effects on the system [7]. Orthogonal Frequency Division Multiplexing (OFDM) has recently modulation technique for high speed communication systems as it reduces intersymbol interference ISI and offers high spectral efficiency. But it has a having drawback of high Peak to Average Power Ratio (PAPR) due to multiple subcarriers which makes it sensitive to non linear effects. Many techniques have been proposed for PAPR reduction in literature review has been discussed.

KEYWORDS: Orthogonal Frequency Division Multiplexing (OFDM), Peak to Average Power Ratio (PAPR), Complementary Cumulative Distribution Function (CCDF), Clipping, Modified Sliding Norm Transform (SNT).

I. INTRODUCTION

OFDM is a spectrally efficient multiple carrier modulation format which converts high data rate channel into multiple lower data rate channels which are spectrally orthogonal to each other. Some of the applications of OFDM include digital subscriber lines, high-definition television broadcasting, and long-term evolution based cellular network long haul optical communication [1,6]. OFDM is considered as a suitable technique for high speed optical communication due its inborn favourable advantages of decrease in intersymbol interference and high spectral efficiency. However, the significant issue with OFDM is high PAPR value which emerges because of large number of subcarriers which increases the non linear effects and also puts a constraint on range of nonlinear network devices such as analog-to-digital converters, amplifiers and modulators. Hence there is a need to lessen the PAPR of OFDM signal in optical OFDM systems [4].

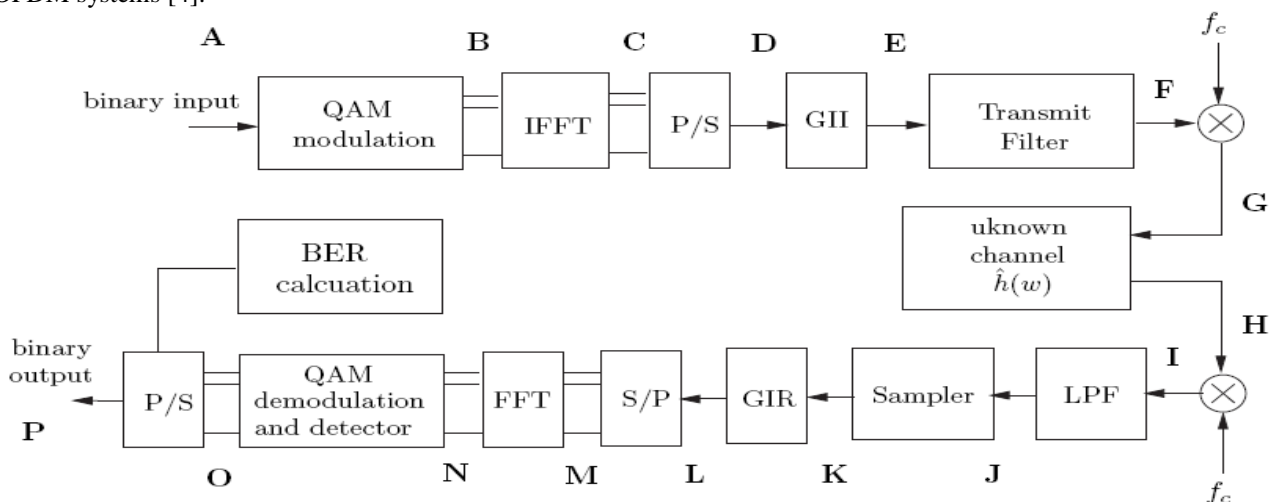

Fig 1: Block diagram of an OFDM system



International Journal of Advanced Research in Electrical, Electronics and Instrumentation Engineering

(An ISO 3297: 2007 Certified Organization)

Vol. 5, Issue 4, April 2016

II. PEAK TO AVERAGE POWER RATIO (PAPR)

Due to presence of large number of independently modulated sub-carriers in an OFDM system the peak value of the system can be very high as compared to the average of the whole system. This ratio of the peak to average power value is termed as Peak-to-Average Power Ratio. Coherent addition of N signals of same phase produces a peak which is N times the average signal.

The major disadvantages of a high PAPR are as follows

1. Increased complexity in the analog to digital and digital to analog converter.
2. Reduction is efficiency of RF amplifiers.

PAPR OF A MULTICARRIER SIGNAL:

Let the data block of length N be represented by a vector $X=[X_0, X_1, \dots, X_{N-1}]$. Duration of any symbol X_k in the set X is T and represents one of the sub carriers set $\{f_n, n=0,1,2,\dots,N-1\}$. As the N sub carriers chosen to transmit the signal are orthogonal to each other, so we can have $f_n = n\Delta f$ where $n\Delta f = 1/NT$ and NT is the duration of the OFDM data block X . The complex data block for the OFDM signal to be transmitted is given by

$$x(t) = \frac{1}{\sqrt{N}} \sum_{n=0}^{N-1} X_n \cdot e^{j2\pi n\Delta f t}, \quad 0 \leq t \leq NT,$$

The PAPR of the transmitted signal is defined as

$$PAPR = \frac{\max_{0 \leq t < NT} |x(t)|^2}{1/NT \int_0^{NT} |x(t)|^2 dt}$$

Reducing the $\max|x(t)|$ is the principle goal of PARP reduction techniques. Since, discrete- time signals are dealt with in most systems, many PAPR techniques are implemented to deal with amplitudes of various samples of $x(t)$. Due to symbol spaced output in the first equation we find some of the peaks missing which can be compensated by oversampling the equation by some factor to give the true PAPR value.

III. PAPR REDUCTION TECHNIQUES

In order to reduce the high PAPR value in optical OFDM systems, various techniques have been proposed in literature. Some of the important techniques are signal clipping, companding, SLM, PTS, nonlinear sliding norm transforms etc.

A. Signal Clipping

Amplitude clipping is a simple technique to reduce the PAPR of OFDM signal. A predefined value of the amplitude is used to limit the peak value of the input signal. Signal having values higher than this threshold value are clipped to the threshold value as follows.

$$F(x) = \{A \text{ when } x > A, \\ A \text{ when } 0 \leq x < A \}$$

The main problem in this case is that the amplitude clipping introduces undesired clipping noise

B. Companding based signal distortion

The companding technique is a pre-distortion process in which the amplitude of the small signal is enlarged while the large signal remains almost the same. Using this method signal amplitude is re-distributed after transformation which results in reduced PAPR. Also, the gain of PAPR reduction and noise enhancement are increased as μ is increased. Hence there is increase in noise due to companding for a constant value of signal-to-noise ratio. It is important to choose values of companding parameters to avoid significant noise.

International Journal of Advanced Research in Electrical, Electronics and Instrumentation Engineering

(An ISO 3297: 2007 Certified Organization)

Vol. 5, Issue 4, April 2016

C. Selected mapping (SLM) for PAPR reduction

In selected mapping method, M independent data blocks $S_m=[S_{m,0},S_{m,1},\dots,S_{m,N-1}]T$, $m=1,2,\dots,M$ represent the same information are obtained by multiplying the original sequence with M uncorrelated sequence P_m . These are then forwarded into IFFT operation simultaneously. And then the PAPR is calculated for each vector separately. The sequence with the smallest PAPR is selected for final transmission. The receiver is required to have information about selected phase vector sequence and ensure that the vector sequence is received correctly. This can degrade the spectral efficiency of the system.

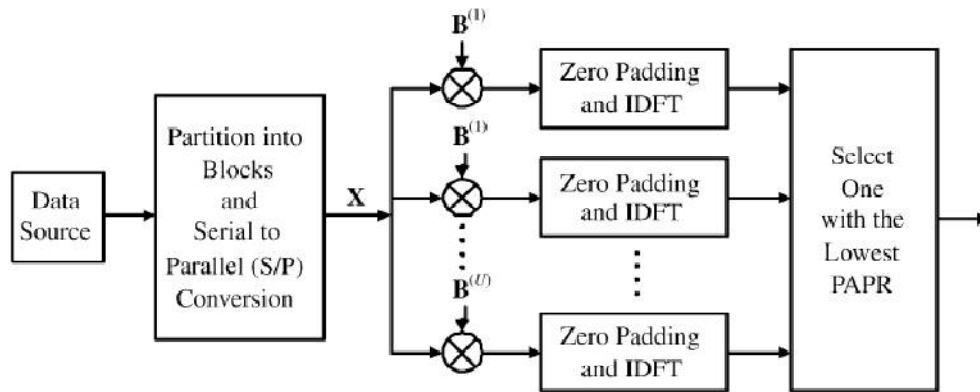

Fig 2. The Block Diagram of Selected Mapping Technique

D. Partial transmit sequence (PTS)

In this method, the original OFDM sequence is divided into several sub-sequences and each sub-sequence is multiplied by different weights until an optimum value is chosen.

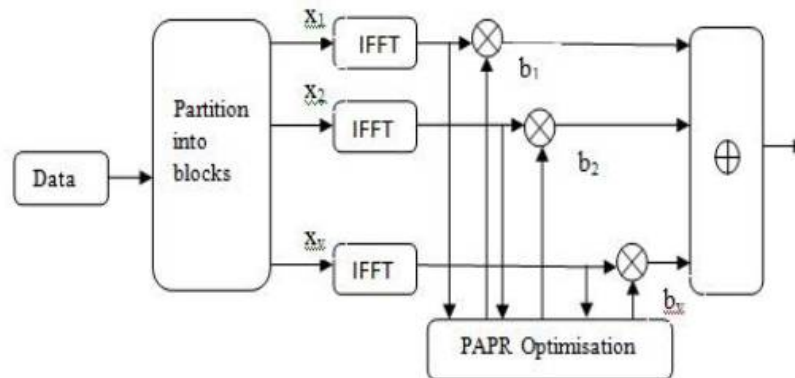

Figure 3. Block diagram of PTS technique for PAPR reduction

IV. LITRATURE REVIEW

(1) **2015,Martha C. Paredes:** In this paper, a novel Constellation Extension (CE) based approach is presented to address the high Peak-to-Average Power Ratio (PAPR) problem at the transmitter side, which is an important drawback of Orthogonal Frequency Division Multiplexing (OFDM) systems. This new proposal is formulated as a Mixed Integer Non-Linear Programming (MINLP) optimization problem, which employs Generalized Benders Decomposition (GBD) and Branch-and-Bound (BB) methods to determine the most adequate extension factor and the optimum set of input symbols to be extended within a proper quarter-plane of the constellation.

(2) **2014, Wasiu O. Popoola, ZabihGhassemlooy, and Brian G. Stewart:** This paper investigates the use of a pilot signal in reducing the electrical peak-to-average power ratio (PAPR) of an orthogonal frequency division multiplexing (OFDM) intensity modulated optical wireless communication system. The phase of the pilot signal is chosen based on



International Journal of Advanced Research in Electrical, Electronics and Instrumentation Engineering

(An ISO 3297: 2007 Certified Organization)

Vol. 5, Issue 4, April 2016

the selected mapping (SLM) algorithm while the maximum likelihood criterion is used to estimate the pilot signal at the receiver.

(3) 2014, Ying-Che Hung and Shang-Ho (Lawrence) Tsai: In this paper, we theoretically analyze the PAPR performance of MIMO OFDM systems that adopt either one of the two popular beams forming schemes, i.e. MRT (maximum ratio transmission) and EGT (equal gain transmission). The analysis considers different numbers of channel taps after sampling.

(4) 2013, YasirRahmatallah, Seshadri Mohan: The review clearly defines the metrics based on which the performance of PAPR reduction schemes can be evaluated. A taxonomy of PAPR reduction schemes classifies them into signal distortion, multiple signaling and probabilistic, and coding techniques with further classification within each category.

(5) 2013, Usama S. Mohammed, Osama A. Omer, Ahmed S. A. Mubarak: This proposed PAPR reduction technique is based on adaptive clipping for the amplitude of the input signal, where each of signals related to the different groups of the modified SPTHT coder is clipped with a different clipping level according to the group sensitivity. To demonstrate the efficiency of the modified OFDM system with proposed PAPR reduction technique, the simulation results are presented based on bit error rate (BER), the Peak-signal-to-noise ratio (PSNR) and PAPR over A WGN channel. Based on the simulation results, the proposed structure provides a significant improvement in BER and PSNR performances and a reduction in PAPR is achieved.

(6) December 2001, Heung-GyoonRyu and Kyoung-Jae Youn: A new SPW method is basically examined. CCDF (complementary cumulative distributed function) of PAPR is evaluated in the cases that both feedback and feed forward type of the side information insertion are devised into the basic SPW method. PAPR reduction efficiency grows up as the number of subblocks is increased. However, there is a slight loss of the spectral efficiency due to the side information insertion. Feasibility of the proposed method and the validity of side information insertion method are proved and compared by the extensive computer simulations in terms of PAPR and computational complexity reduction. Therefore, the proposed SPW method can be applied into multicarrier system like OFDM as more effective PAPR reduction method.

(7) 2008, Sungkeun Cha, Myonghee Park, Sungeun Lee, Keuk-joon Bang, and Daesik Hong: In this paper, we investigate an advanced peak windowing method as a peak-to-average power ratio (PAPR) reduction technique in orthogonal frequency division multiplexing (OFDM) systems. The advanced peak windowing method is performed by introducing new weighting coefficients in case those successive peaks are generated within a half of the window length. Applying the new weighting coefficients, we can tightly limit the successive peaks to the given threshold level. Through a computer simulation, we verify that the BER performance improvement can be achieved by the proposed peak windowing method while maintaining almost the same complementary cumulative distribution function (CCDF) and spectral characteristics.

(8) December 2008, L. Yang, K. K. Soo, Y. M. Siu, and S. Q. Li: By using the time domain sequence superposition (TDSS) technique, in this paper, we propose a low complexity selected mapping (LC-SLM) scheme for the peak-to-average power ratio (PAPR) reduction of the orthogonal frequency division multiplexing (OFDM) system. Unlike the conventional selected mapping (SLM) scheme which needs several inverse fast Fourier transform (IFFT) operations for an OFDM signal, the proposed scheme requires to implement two IFFT operations only. Thus, it can remarkably reduce the computational complexity. Simulation results show that the proposed scheme can achieve similar PAPR performance as the conventional SLM scheme.

(9) 2006, GuosenYue and Xiaodong Wang:The scheme can be directly applied to multiple-input multiple-output (MIMO) OFDM systems. The capacity of the clipped MIMO-OFDM systems is analyzed based on a Gaussian approximation of the clipping noise. We consider an iterative receiver with soft MAP MIMO-OFDM detector. For both single antenna and multiple antenna systems, the encoder part is independent in the hybrid scheme, thus no additional constraint is applied to the IRA code optimization. The IRA codes are designed for the ergodic MIMO-OFDM systems



International Journal of Advanced Research in Electrical, Electronics and Instrumentation Engineering

(An ISO 3297: 2007 Certified Organization)

Vol. 5, Issue 4, April 2016

with different PAPR reduction settings, more specifically different clipping ratios, based on the extrinsic information transfer (EXIT) charts. Simulation results show that the hybrid scheme with 3dB clipping can achieve as good PAPR reduction performance as the simple clipping with 0dB ratio but incurs much less performance loss at the receiver.

(10) March 2006, Miguel R. D. Rodrigues Ian J. Wassell: In this paper, the authors propose selective mapping (SLM) and partial transmit sequences (PTS) employing an inter modulation distortion (IMD)-reduction strategy to improve the error-probability performance of nonlinearly distorted orthogonal frequency division multiplexing (OFDM). In particular, the authors consider two IMD-reduction criteria: One requires knowledge of nonlinearity parameters, whereas the other does not. Simulation results demonstrate that in the presence of nonlinearities, OFDM systems using SLM or PTS with either of the IMD-reduction strategies perform better than those with peak to- average power ratio (PAPR) or the recently proposed excess power (EP)-reduction strategies. Furthermore, the error-probability performance of the IMD-reduction technique that exploits knowledge of nonlinearity parameters is only slightly better than that of the technique that does not. Additionally, simulation results also demonstrate that the average out-of-band power generated by the IMD-reduction strategies is similar to that generated by PAPR or EP reduction.

(11) September 2004, SeungHeeHanand Jae Hong Lee: High peak-to-average power ratio (PAPR) of the transmitted signal is a major drawback of orthogonal frequency division multiplexing (OFDM). In this paper, we propose a modified selective mapping (SLM) technique for PAPR reduction of coded OFDM signal. In this technique, we embed the phase sequence, which is used to lower the PAPR of the data block, in the check symbols of the coded OFDM data block [11]. It is shown that we can achieve both PAPR reduction from the SLM technique as well as error performance improvement from the channel coding with no loss in data rate from the transmission of side information. In addition, approximate expression for the complementary cumulative distribution function (CCDF) of the PAPR of the modified SLM technique is derived and compared with the simulation results.

(12) November 2004, SeungHeeHanand Jae Hong Lee: A major drawback of orthogonal frequency division multiplexing (OFDM) is the high peak-to-average power ratio (PAPR) of the transmitted signal. Partial transmit sequence (PTS) technique can improve the PAPR statistics of OFDM signals. In the PTS technique, the data block to be transmitted is partitioned into disjoint sub blocks and the sub blocks are combined using phase factors to minimize PAPR. As ordinary PTS technique requires an exhaustive search over all combinations of allowed phase factors, the search complexity increases exponentially with the number of sub blocks. In the proposed technique, a gradient descent search is performed to find the phase factors. It is shown that the proposed technique achieves significant reduction in search complexity with little performance degradation [12].

V.CONCLUSION AND FUTURE WORK

OFDM is a promising technique for very high speed communication systems as it offers spectral efficiency and reduces intersymbol interference. But OFDM has inherent drawback of high PAPR due to a large number of subcarriers. Various methods have been proposed for reduction of PAPR of OFDM signal. The simplest method is clipping but it introduces noise for large clipping ratio. PTS and SLM give good performance but require extra information for reception. Modified SNT do not need any side information but PAPR reduction needs to be enhanced. In future we improve BER(Bit Error Rate) and proven that PTS is better than SLM technique so that System exhibits good performance in terms of BER using PAPR reduction technique.

REFERENCES

- [1].NedaCvijetic,"OFDM for Next-Generation Optical Access Networks." Journal of light wave technology, vol. 30, no. 4, February 15,2012.
- [2]. Armstrong, J., "OFDM for Optical Communications." Journal of Lightwave Technology, 27(3), pp.189–204, 2009.
- [3]. Lin CHEN, Yong FANG," PAPR Reduction in Optical OFDM Systems Using Asymmetrically Clipping and Filtering Technique."Journal of Computational Information Systems 8: 7 2733–2740,2012.
- [4]. Wang, Jianping, Ying Guo, and Xianwei Zhou, "PTS-clipping method to reduce the PAPR in ROF-OFDM system." Consumer Electronics, IEEE Transactions on 55.2 (2009): 356-359, 2009.
- [5]. Yufeng Shao, Nan Chi, Jingyuan Fan, and WuliangFang,"Generation of 16-QAM-OFDM Signals using Selected Mapping Method and Its Application in Optical Millimeter-Wave Access System." IEEE Photonics Technology Letters, VOL. 24, NO. 15, August 1, 2012.
- [6]. Dursun, S. &Grigoryan, A.M., " Nonlinear L2-by-3 transform for PAPR reduction in OFDM systems."Computers& Electrical Engineering, 36(6), pp.1055–1065, 2010.
- [7]. Salmanzadeh, Rahim, and BehzadMozaffariTazehkand. "A Modified Method Based on the Discrete Sliding Norm Transform to Reduce the PAPR in OFDM Systems." ETRI Journal 36.1 : 42-50.2014.



ISSN (Print) : 2320 – 3765
ISSN (Online): 2278 – 8875

International Journal of Advanced Research in Electrical, Electronics and Instrumentation Engineering

(An ISO 3297: 2007 Certified Organization)

Vol. 5, Issue 4, April 2016

- [8]. Popoola, Wasiu O., Zabih Ghassemlooy, and Brian G. Stewart. "Pilot-assisted PAPR reduction technique for optical OFDM communication systems." *Journal of Lightwave Technology* 32.7 (2014): 1374-1382.
- [9]. M. Hariharan, M. Gurunathan, A. Gopi, M. Palanivelan & Sheila Anand, "Non Linear Transform Technique to Optimize PAPR in Optical OFDM (O-OFDM) Systems." *International Conference on Computer Science and Information Technology*, 10, March 2013.
- [10]. Lim, Dae-Woon, Seok-Joong Heo, and Jong-Seon No. "An overview of peak-to-average power ratio reduction schemes for OFDM signals." *Communications and Networks, Journal of* 11.3: 229-239. 2009.
- [11]. Yu, Zhenhua, Robert J. Baxley, and G. Tong Zhou. "Iterative Clipping for PAPR Reduction in Visible Light OFDM Communications." *Military Communications Conference (MILCOM), 2014 IEEE*. IEEE, 2014.