



# **Design of a Hybrid Modulated Inverter For Fuel Cell Vehicle**

V.Vinoth<sup>1</sup>, N.Karthick<sup>2</sup>, V.S.Chandrika<sup>3</sup>

<sup>1</sup> PG Scholar, Department of EEE, P.S.V. College of Engineering & Technology, Krishnagiri, Tamilnadu, India

<sup>2</sup> Assistant Professor, Department of EEE, P.S.V. College of Engineering & Technology, Krishnagiri, Tamilnadu, India

<sup>3</sup> Professor, Department of EEE, P.S.V. College of Engineering & Technology, Krishnagiri, Tamilnadu, India

**ABSTRACT:** This Paper presents the hybrid modulation technique containing of single reference six pulse modulation (SRSPM) for front end dc-dc converter and 33% modulation for 3 phase inverter. The SRSPM technique is used to control the front end dc/dc converter which produces high frequency (HF) pulsating dc voltage waveform this is relevant to Six pulse at 6x line frequency. Where 6x line frequency rectified 6-pulse o/p of balanced 3 phase AC wave form. Here the Dc link capacitor is eliminated which retains the modulated information of the inverter device to generate 3 phase voltage waveform resulting in significant saving in switching losses of inverter semiconductor devices. During line cycle only 2 switches are required to switch at HF and remaining switches are maintained at unique state (i.e.) either ON or OFF .This Paper explains operation and analysis of the HF two stage inverter with SRSPM technique. Analysis has been verified through simulation result using MATLAB.

**KEYWORDS:** Electric vehicle, Fuel cell vehicle, High frequency, Six Pulse modulation, three phase inverters.

## **I.INTRODUCTION**

The Fossil fuel resources are at alarming rate the demand fossil has been increased in recent years, since the energy consumed and demanded by transportation sector has risen due to the increase in no. of vehicles as the transportation accounts for above 20% total energy. In order to overcome this conventional energy sources are being used now-a-days as alternative energy solution to provide green energy.

In the conventional vehicle 10-15% of fuel in converted to traction due to poor performance of internal combustion engine (ICE) while in case of hybrid electric vehicle (HEV) it can boost efficiency to 30-40% by increase fuel economy which reduce CO<sub>2</sub> emission but not like electric vehicles (EVS). The major challenge in EVS is energy storage and quick charging of energy storage device.

The fossil fuel vehicle (FCVS) are next generation transportation system with zero emission to keep environmental clean .FCVS have the significantly reduces the need for the foreign fuel. FCVS are efficient and same as EVS.FCVS are free from the driving range and charging time limits. However, this has a major challenge on cost, safety, on board hydrogen storage.

FCVS are been tested in countries like U.S, Canada, Germany not only in cars but also in public transportation. The Automotive industries like Honda, Toyota, GM, ford and Kia Ria are designing the FCVs. The architecture of the fuel cell car along with its major components are given in the fig.1.Any device needs a energy storage element and hence based on the characteristics and dynamics of the fuel cell optimal energy storage device like battery or ultra capacitor is selected. A 12-V battery is used to supply power to the auxiliary loads in the vehicle which can also be used with a bi-directional dc/dc converter.

# International Journal of Advanced Research in Electrical, Electronics and Instrumentation Engineering

(An ISO 3297: 2007 Certified Organization)

Vol. 4, Issue 10, October 2015

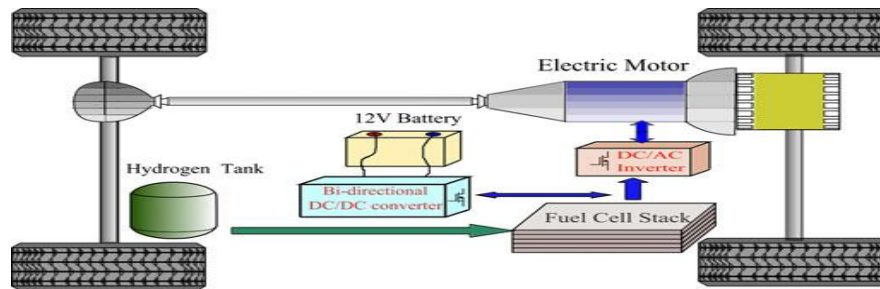

Fig. 1. Architecture of a fuel cell car.

A HF two stage Z-source inverter is employed to convert 100 V into three phase AC voltage, which is used to drive the motor of the vehicle. A voltage fuel cell stack needs a multistage inverter to boost its low voltage to generate three phase voltage signal. HF modulation is adopted to achieve compact, low cost and light weight system. The two stage HF inverter consist of Front end dc-dc converter connected to a standard three phase width modulated (PWM) inverter as shown in fig.2.

This paper presents a hybrid modulation technique which has two different modulations for two stages. Single reference six pulse modulation (SRSPM) is done to control the front end dc/dc converter to produce high pulsating dc voltage which produce six pulse information which requires a single reference signal The second modulation is adopted for a three phase Z- source inverter which produces a balanced three phase voltage. In the inverter modulation only one leg is modulated at a time and the other two legs are at the same switching state which reduces the switching frequency and limits the switching losses. Interleaving is done to increase the power transfer capacity. This act of modulating only one bridge at a time adds advantage to the proposed system as even if one bridge fails the other bridge maintains the six pulse information in the pulsating dc –link voltage and the inverter will still be able to produce the balanced three phase voltage.

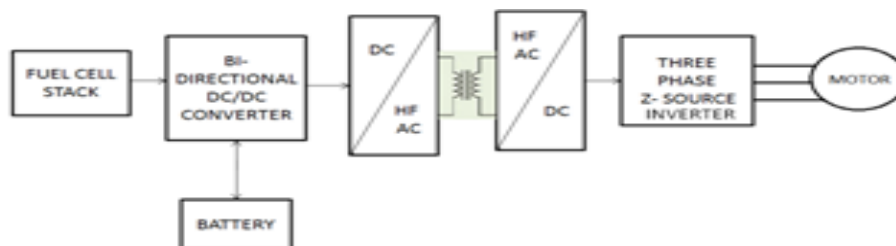

Fig 2. Functional diagram of a fuel cell propulsion system.

The overall merit of the system are (1) Robust.(2) Eliminating dc – link capacitor reduce the volume of system and increases reliability. (3) Reduced switching losses and improved efficiency. (4) Use of the Z-source inverter provides additional advantage such as: (i) produce any desired output ac voltage, even greater than the line voltage, regardless of the input voltage, thus reducing motor ratings; (ii) provide ride-through during voltage sags without any additional circuit (iii) improve power factor and reduce harmonic current and common-mode voltage.

The objective of this paper is to explain the operation of the two stages HF Z – source inverter employing proposed modulation scheme, reported in section II. The design of the converter is illustrated in section III.

The analysis and design have been verified by HARDWARE.

## II. OPERATION

The steady state operation and analysis of the modulation technique have been explained in this section. To increase the power handling capacity full bridge converter are interleaved at front end input series output as shown in

## International Journal of Advanced Research in Electrical, Electronics and Instrumentation Engineering

(An ISO 3297: 2007 Certified Organization)

Vol. 4, Issue 10, October 2015

fig 4. The full bridge are modulated with six pulse modulation which produces high frequency pulsating dc voltage, which is fed to the three phase z- source inverter. To reduce the switching losses the modulation of the two stage is planned, developed and implemented.

To obtain the balanced three phase sine inverter output voltage of required frequency and amplitude the three phase inverter is modulated to shape the high frequency dc voltage of the two bridge converter. The following assumptions are made for easy understanding of the analysis of the converter: 1) All semiconductor devices and components are ideal and lossless. 2) Leakage inductances of the transformers have been neglected. 3) Dc/dc converter cells are switched at higher frequency compared to the inverter. Therefore, current drawn by the inverter,  $i_{dc}$  remains approximately constant over one HF switching cycle of the dc/dc converter.

### A. MODULATION:

The bridge A consist of switches  $M_{1a}, M_{2a}, M_{3a}, M_{4a}$  and bridge B has  $M_{1b}, M_{2b}, M_{3b}, M_{4b}$  as shown in fig.3. The switch pair  $M_{1a} - M_{2a}$  and  $M_{3a} - M_{4a}$  are operated with complementary signal. The gating signals of  $M_{1a}, M_{3a}$  is phase shifted by  $DT_s$ , where D is the duty ratio of the switch. The voltage at the rectifier output can be varied by varying D, D is generated by comparing reference signal with carrier signal.

TABLE 1. MODULATION SIGNALS FOR SWITCHING OF THE INVERTER:

	$T_1$	$T_2$	$T_3$	$T_4$	$T_5$	$T_6$
$S_1, \bar{S}_2$	$V_{ab} / V_{cb}$	ON	ON	$V_{ac} / V_{bc}$	OFF	OFF
$S_3, \bar{S}_4$	OFF	OFF	$V_{bc} / V_{ac}$	ON	ON	$V_{ba} / V_{ca}$
$S_5, \bar{S}_6$	ON	$V_{cb} / V_{ab}$	OFF	OFF	$V_{ca} / V_{ba}$	ON

The reference signal  $V_{ref}$  is a six pulse rectified output voltage of the three phase line-line. The reference voltage has frequency of  $6 \times ac$  line frequency. The six pulse are noted as  $T_1$  to  $T_6$ . During each pulse only one leg of the inverter is modulated at high frequency and the remaining two legs are kept steady at their switching state.

The modulating sequence of the inverter switches  $S_1 - S_6$  are given in table 1. During the time interval  $T_1$ , switch  $S_4$  &  $S_5$  are ON and switch pair  $S_3$  &  $S_6$  are OFF,  $S_1$  &  $S_2$  are modulated at high frequency by using  $V_{ab} / V_{cb}$  as modulating signal. We can understand this clearly from the fig.4 where only two switch (one leg) of six switch (three leg) are switched at high frequency which results in reducing the number of switching instants in a line cycle.

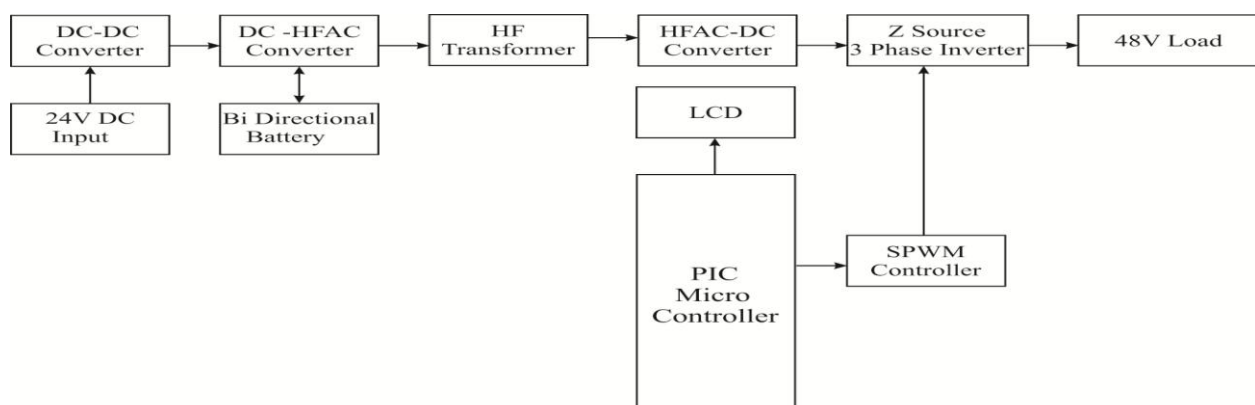

Fig. 3. Block diagram of the proposed fuel cell inverter system.



## International Journal of Advanced Research in Electrical, Electronics and Instrumentation Engineering

(An ISO 3297: 2007 Certified Organization)

Vol. 4, Issue 10, October 2015

As already said in a complete line cycle each semiconductor device is switched at high frequency for only one third of the line cycle, at the same time the device are not commutated when the current is at its peak value. This reduces the switching losses less than 33%. The exact modulating signal are calculated by varying the average dc-link voltage as six pulse modulation. This can be easily implemented by using three phase line-line voltage as shown in fig.5.

### B. STEADY STATE OPERATION:

Each switch in the full bridge are operated 50 % duty ratio which are complementary to the other switch in same leg. Whenever the diagonal switch pairs are conducting for eg.  $M_{1a}$  &  $M_{4a}$ , then the input voltage  $V_{in}$  is reflected on the secondary side on other side when the another diagonal pair  $M_{2a}$  &  $M_{3a}$  are conducting  $-nV_{in}$  appears across secondary terminal, where n is the turns ratio of the transformer. Same procedure is applied for bridge B. The bipolar pulsating voltage is converted into unipolar using the full bridge diode rectifier.

The duty ratio is obtained from  $V_{ref}$  of the six pulse waveform, which varied between maximum value  $D_{max}$  and minimum value  $D_{min}$  for the required three phase output voltage.

### C. SWITCHING LOSSES:

As explained the devices of the three phase inverter switch is operated only for 1/3<sup>rd</sup> of the line cycle. The switch is kept in the on-state for 1/3<sup>rd</sup> of the cycle conducting the peak current of the output line current when the output power factor is unity and in the OFF state for rest 1/3<sup>rd</sup> of the line cycle. When the top switch is in OFF state the line current is at negative peak and is ON state for the bottom switch. When the line current crosses zero the device are switched at high frequency and hence the switching losses in the inverter are reduced.

## III. DESIGN OF Z - SOURCE INVERTER

The simulation system are set up with the following parameters.

- 1) Three-phase line voltage: 230 V
- 2) Load: three-phase PM DC motor.
- 3) Z-source network
- 4) Switching frequency of dc/dc converter  $f = 100$  kHz, and of inverter  $f_{SI} = 40$  kHz

The use of the Z-source inverter system adds several advantages such as 1) it produces desired output ac voltage, even greater than the line voltage; 2) provides ride through during voltage sags without any additional circuits and energy storage; 3) It minimizes the motor ratings to deliver the required power; 4) reduces in-rush and harmonic current. The presence of the capacitor and the inductor in the z- source inverter reduces the switching losses.

The switches are commutated at HF for only one third of the line cycle which results in significant saving in switching losses. It is also observed that only one of the legs is switching at HF, remaining two device legs being connected to either  $V_{dc}$  (off) or 0 (on). In order to generate pulsating dc voltage at  $V_{dc}$ , semiconductor devices are modulated with the varying duty ratio generated from the six-pulse signal,  $V_{ref}$ . The duty ratio of front end converter varies nearly 15% over frequency of  $6 \times$  line frequency.

Since the LC filter eliminates the HF components it results in low harmonic distortion of the inverter output waveforms. Switches are controlled using gating pulses that are generated by comparing  $V_{ref}$  with the carrier signal. Whenever diagonal switches are conducting, the input voltage appears across the transformers. During remaining time of the HF switching cycle, voltage across the transformers is clamped to zero. Two identical bipolar voltages are obtained at the secondary of the transformers. These two voltages are rectified to obtain unipolar voltage waveforms the power transfer at 50% and rated load as a result of negligible or very low leakage inductance of the HF transformers. The modulation still works due to the single-reference technique and produces balanced three-phase sine output waveforms with low distortion.

## International Journal of Advanced Research in Electrical, Electronics and Instrumentation Engineering

(An ISO 3297: 2007 Certified Organization)

Vol. 4, Issue 10, October 2015

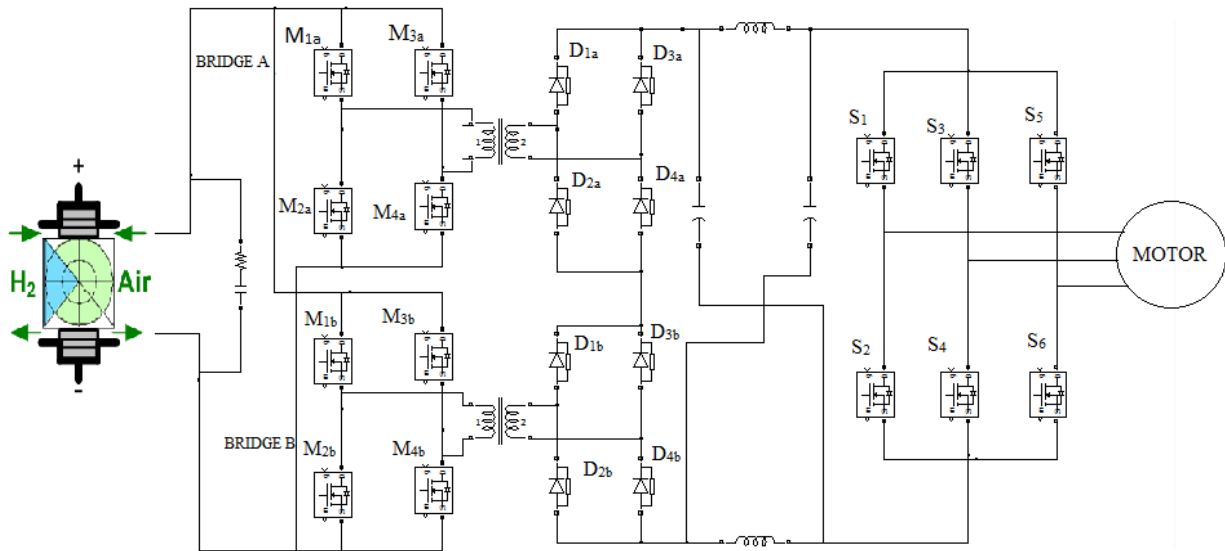

Fig. 4. Schematic of the proposed fuel cell inverter system.

. However, it is clear that the mode changes from high voltage low current to low voltage high current due to the failure of one bridge. But it is still able to drive the vehicle to home or garage, which adds a valuable feature to the power electronics system in vehicle and improves the reliability making it fault tolerant. In case of other applications, the power electronics system still resumes the power from source to the load and helps to maintain the continuity and thus improve the reliability of power electronics.

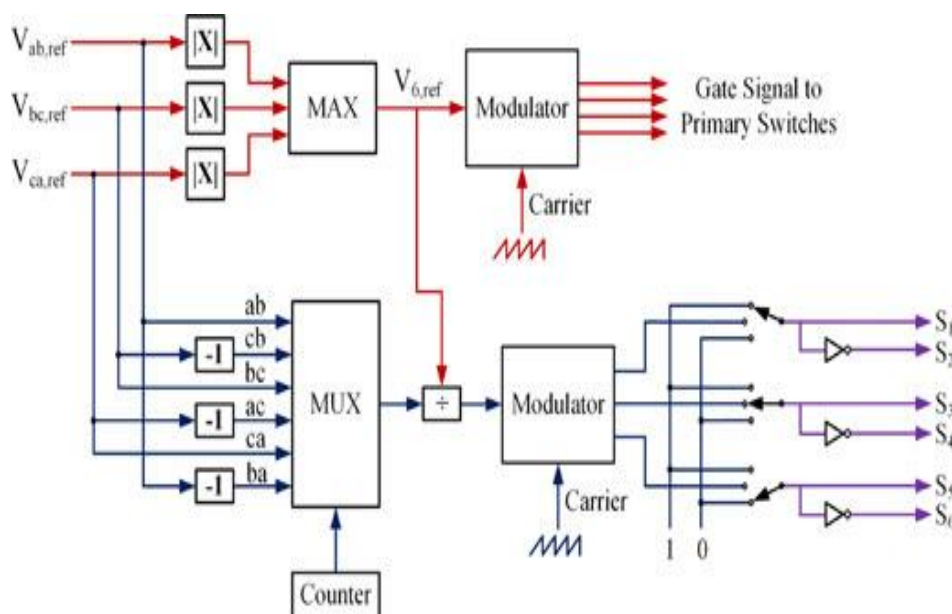

Fig. 5. Schematic of complete modulation implementation.

# International Journal of Advanced Research in Electrical, Electronics and Instrumentation Engineering

(An ISO 3297: 2007 Certified Organization)

Vol. 4, Issue 10, October 2015

## IV. SIMULATION RESULTS

The proposed modulation scheme has been simulated using software package MATLAB for the given specifications. Simulation results are illustrated in Figs. 5 to 8.

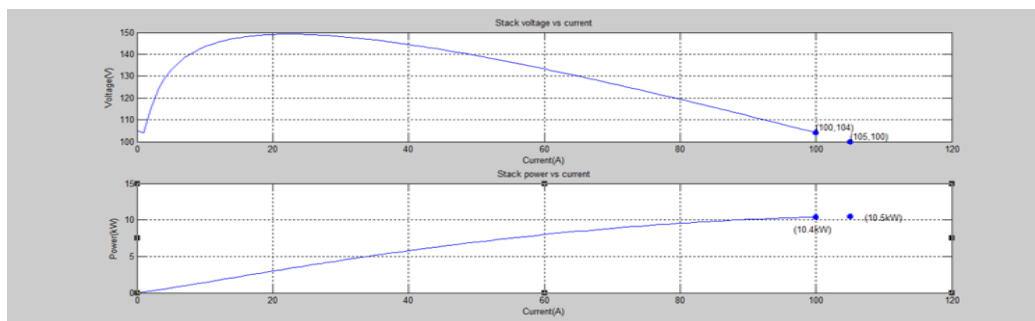

Fig 6. Simulation results showing input voltage and power waveforms at the fuel cell stack.

Figure 6 shows the input voltage and power from the fuel cell stack. Were the voltage vs. current and power vs. current waveforms are provided. .

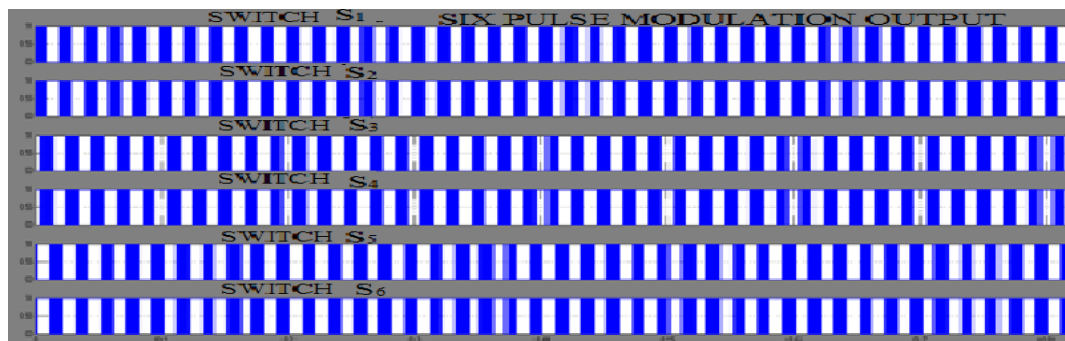

Fig 7 Simulation results showing six pulse width modulation

Figure 7 shows the six pulse modulated output in the z- source inverter were the pulse signal of each switch from  $S_1$  to  $S_6$  are given at the current time interval.

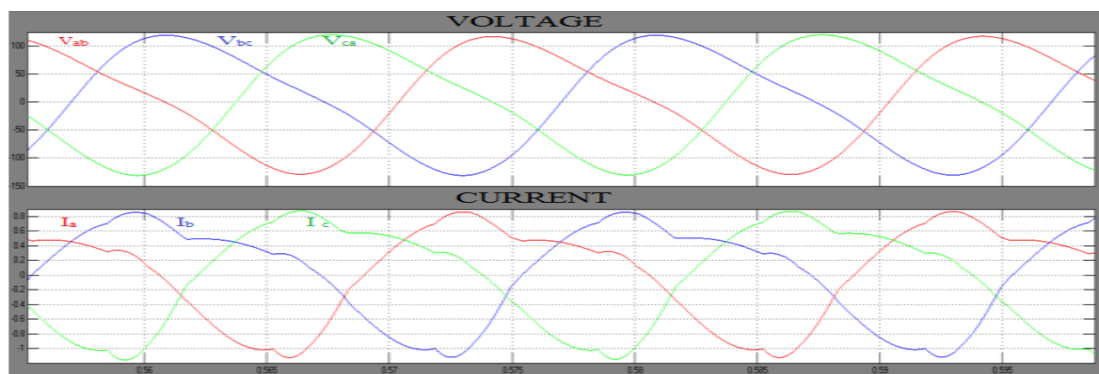

Fig 8 Simulation results showing ( $V_{ab}$ ,  $V_{bc}$ , and  $V_{ca}$ ),output phase voltages and output line current ( $I_a$ ,  $I_b$ , and  $I_c$ )

# International Journal of Advanced Research in Electrical, Electronics and Instrumentation Engineering

(An ISO 3297: 2007 Certified Organization)

Vol. 4, Issue 10, October 2015

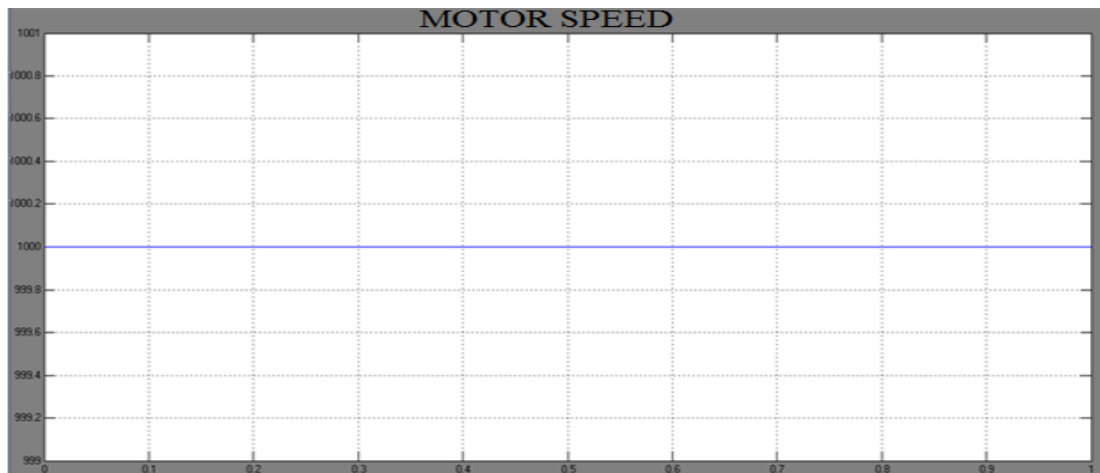

Fig 9. Simulation results showing speed of the motor under normal condition.

. Figure 8 shows the output phase voltage and the output line current waveforms. Figure 9 gives the speed of the motor.

The switches are commutated at HF for only one third of the line cycle which results in significant saving in switching losses. It is also observed that only one of the legs is switching at HF, remaining two device legs being connected to either  $V_{dc}$  (off) or 0 (on). In order to generate pulsating dc voltage at  $V_{dc}$ , semiconductor devices are modulated with the varying duty ratio generated from the six-pulse signal,  $V_{ref}$ . The duty ratio of front end converter varies nearly 15% over frequency of  $6 \times$  line frequency.

Since the LC filter eliminates the HF components it results in low harmonic distortion of the inverter output waveforms. Switches are controlled using gating pulses that are generated by comparing  $V_{ref}$  with the carrier signal. Whenever diagonal switches are conducting, the input voltage appears across the transformers. During remaining time of the HF switching cycle, voltage across the transformers is clamped to zero. Two identical bipolar voltages are obtained at the secondary of the transformers. These two voltages are rectified to obtain unipolar voltage waveforms the power transfer at 50% and rated load as a result of negligible or very low leakage inductance of the HF transformers. The modulation still works due to the single-reference technique and produces balanced three-phase sine output waveforms with low distortion. However, it is clear that the mode changes from high voltage low current to low voltage high current due to the failure of one bridge. But it is still able to drive the vehicle to home or garage, which adds a valuable feature to the power electronics system in vehicle and improves the reliability making it fault tolerant. In case of other applications, the power electronics system still resumes the power from source to the load and helps to maintain the continuity and thus improve the reliability of power electronics.

## V. SUMMARY AND CONCLUSION

Fuel cell vehicles are one of the most important to provide solution toward sustainable low carbon clean mobility owing to zero emission. Volume, cost, efficiency, reliability, and robustness of power electronics are the important features of the power electronics system. This paper proposes a modulation technique named SRSPM to control front-end full-bridge converter to generate HF unipolar pulsating voltage waveform at dc link having six-pulse information if averaged at HF cycle over line frequency. Six-pulse is meant for six-pulse waveform that results after rectification of three-phase balanced ac waveforms at  $6 \times$  of line frequency. It permits the next three-phase inverter devices to switch at HF during 33.33% (1/3rd) of the line cycle and remains to stay at steady switching state of ON for 33.33% and OFF for rest 33.33% of line cycle. It results in low average switching frequency or 66.66% reduction in switching transition losses and improved efficiency.

It is suitable for high-power applications like FCVs and EVs, three-phase uninterruptible power supply (UPS), islanded or standalone micro grid, and solid-state transformer.



# International Journal of Advanced Research in Electrical, Electronics and Instrumentation Engineering

(An ISO 3297: 2007 Certified Organization)

Vol. 4, Issue 10, October 2015

The proposed modulation technique eliminates the need for dc-link capacitor and feeds directly HF pulsating dc voltage to a three-phase inverter. This pulsating waveform is utilized to generate three-phase output voltage at reduced average switching frequency (one third of the inverter switching frequency) or 33% commutations of inverter devices in a line cycle. The steady-state operation and analysis of the two stage HF inverter controlled by the proposed modulation scheme have been discussed.

## REFERENCES

- [1] Diego Feroldi, Maria Serra, and Jordi Riera “Design and Analysis of Fuel-Cell Hybrid Systems Oriented to Automotive Applications”.
- [2] A. Emadi and S. S. Williamson, “Fuel cell vehicles: Opportunities and challenges,” in Proc. IEEE Power Energy Society General Meeting, 2004, pp. 1640–1645.
- [3] Gui-Jia Su, Donald J. Adams Oak Ridge National Laboratory Fang Z. Peng “A Soft-Switched DC/DC Converter for Fuel Cell Vehicle Applications” Michigan State University Hui Li Tyco Electronics
- [4] S. Aso, M. Kizaki, and Y. Nonobe, “Development of hybrid fuel cell vehicles in Toyota,” in Proc. IEEE Power Convers. Conf., 2007, pp. 1606–1611.
- [5] E. Schaltz, A. Khaligh, and P. O. Rasmussen, “Influence of battery/ultracapacitor energy-storage sizing on battery lifetime in a fuel cell hybrid electric vehicle,” IEEE Trans. Veh. Technol., vol. 58, no. 8, pp. 3882–3891, Oct. 2009.
- [6] A. Emadi, S. S. Williamson, and A. Khaligh, “Power electronics intensive solutions for advanced electric, hybrid electric, and fuel cell vehicular power systems,” IEEE Trans. Power Electron., vol. 21, no. 3, pp. 567–577, May 2006.
- [7] A. Khaligh and Z. Li, “Battery, ultracapacitor, fuel cell, and hybrid energy storage systems for electric, hybrid electric, fuel cell, and plug-in hybrid electric vehicles: State of the art,” IEEE Trans. Veh. Technol., vol. 59, no. 6, pp. 2806–2814, Jul. 2010.
- [8] S. S. Williamson and A. Emadi, “Comparative assessment of hybrid electric and fuel cell vehicles based on comprehensive well-to-wheels efficiency analysis,” IEEE Trans. Veh. Technol., vol. 54, no. 3, pp. 856–862, May 2005.
- [9] F. Krismer, S. Round, J. W. Kolar ETH Zurich, “Performance Optimization of a High Current Dual Active Bridge with a Wide Operating Voltage Range” Power Electronic Systems Laboratory ETL 116, Physikstrasse ]
- [10] J.-S. Kim, J.-M. Ko, B.-K. Lee, H.-B. Lee, T.-W. Lee and J.-S. Shim, “Optimal battery design of FCEV using a fuel cell dynamics model,” in Proc. Telecommun. Energy Conf., 2009, pp. 1–4.
- [7] E. Schaltz, A. Khaligh, and P. O. Rasmussen, “Influence of battery/ultracapacitor energy-storage sizing on battery lifetime in a fuel cell hybrid electric vehicle,” IEEE Trans. Veh. Technol., vol. 58, no. 8, pp. 3882–3891, Oct. 2009.
- [8] S. J. Jang, C. Y. Won, B. K. Lee, and J. Hur, “Fuel cell generation system with a new active clamping current-fed half-bridge converter,” IEEE Trans. Energy Convers., vol. 22, no. 2, pp. 332–340, Jun. 2007.
- [9] A. K. Rathore, A. K. S. Bhat, and R. Oruganti, “Analysis, design, and experimental results of wide range ZVS active-clamped L-L type current-fed dc/dc converter for fuel cells to utility interface,” IEEE Trans. Ind. Electron., vol. 59, no. 1, pp. 473–485, 2012.
- [10] A. Emadi, K. Rajashekara, S. S. Williamson, and S. M. Lukic, “Topological overview of hybrid electric and fuel cell vehicular power system architectures and configurations,” IEEE Trans. Veh. Technol., vol. 54, no. 3, pp. 763–770, May 2005.
- [11] C. C. Chan, Fellow IEEE “The State of the Art of Electric, Hybrid, and Fuel Cell Vehicles”.
- [12] S. J. Jang, C. Y. Won, B. K. Lee, and J. Hur, “Fuel cell generation system with a new active clamping current-fed half-bridge converter,” IEEE Trans. Energy Convers., vol. 22, no. 2, pp. 332–340, Jun. 2007
- [13] Prof. A. BOUSCAYROL, Dr. R. TRIGUI L2EP, “Generalities on electric vehicles hybrid electric vehicles” based on MEGEVH tutorial at IEEE-VPPC 2009 University Lille1, LTE, IFSTTAR, MEGEVH network,
- [14] R. Huang and S. K. Mazumder, “A soft switching scheme for multiphase dc/pulsating-dc converter for three-phase high-frequency-link pulse width modulation (PWM) inverter,” IEEE Trans. Power Electron., vol. 25, no. 7, pp. 1761–1744, Jul. 2010.
- [14] Cundev Dobri1, Mindl Pavel2 “Energy saving and environment friendly technology of hybrid-electric vehicle with new power transmission and energy recuperation approach” .
- [15] Hengbing Zhao and Andrew Burke “Effects of Different Power train Configurations and Control Strategies on Fuel Economy of Fuel Cell Vehicles” Institute of Transportation Studies, University of California One Shields Ave., Davis, CA 95616, USA.
- [16] Zahra Amjadi “Power Electronics Intensive Energy Management Solutions for Hybrid Electric Vehicle Energy Storage Systems”.