



# **Design of Fixed Order Robust Discrete Controller Using Frequency-Domain Robust Controller Design Toolbox**

Deepika<sup>1</sup>, Shiv Narayan<sup>2</sup>

M.E. Scholar, Department of Electrical, PEC University of Technology, Chandigarh, India<sup>1</sup>

Professor, Department of Electrical, PEC University of Technology, Chandigarh, India<sup>2</sup>

**ABSTRACT:** The objective of the paper is to design the robust discrete  $H_\infty$  controller for dc motor position control using Frequency-Domain Robust Controller Design Toolbox. In this paper, the time performance characteristics of 2<sup>nd</sup> and 3<sup>rd</sup> order controller has been compared by taking dc motor as a design example. The paper aims at demonstrating and simple modelling and robust discrete control synthesis strategies.

**KEYWORDS:** transfer function, discrete systems, robust control, mixed sensitivity,  $H_\infty$  controller synthesis, weighting functions.

## **I. INTRODUCTION**

The Robust Control is very popular and powerful area. Robust control methods aim to design a controller for an uncertain model belonging to a bounded set. A large amount of research papers and books have been published in this subject and research is still in progress to develop new algorithms with less conservatism[18]. The conservatism can be related to the uncertainty modeling, specially during conversion of one type of uncertainty to one that can be treated by the robust control design algorithm[16].

The most efficient and established algorithms for robust control analysis and design are gathered in Robust Control Toolbox of Matlab together with additional commands for closed-loop and controller structure definition, weighting filter design for performance and uncertainty and controller reduction commands[2][4]. The main robust control synthesis commands are used for  $H_\infty$  loop shaping, optimal  $H_\infty$  control,  $\mu$ -synthesis [1] and  $H_\infty$  fixed-structure controller tuning. In this paper, the frequency domain robust controller toolbox is used for designing the robust fixed order controller. The Frequency-Domain Robust Controller Design Toolbox [16] is a tool for finding the robust linearized parametric controllers in Nyquist plot. It can be used to design linearly parametric controllers of any order for parametric as well as for non parametric models.

It should be mentioned that the Frequency-Domain Robust Control (FDRC) toolbox is available for free in [8]. This toolbox can be used to compute  $H_\infty$  decoupling controllers for MIMO systems as well as gain scheduled controllers based on [16] and [17], respectively. It can also be used for PID controller design with constraints on the gain margin, phase margin and the crossover frequency [15]. However, in this paper we do not aim to presents all obtains and abilities of this toolbox and we limit ourself to robust controller design for SISO systems with  $H_\infty$  performance.

The paper is organized as follows. Next section recalls the  $H_\infty$  controller framework. Then, section III shows the introduction of Frequency Domain Robust Controller Toolbox. The section IV describes the design model of Dc motor. Then, the simulations and results have been presented.



# International Journal of Advanced Research in Electrical, Electronics and Instrumentation Engineering

(An ISO 3297: 2007 Certified Organization)

Vol. 4, Issue 6, June 2015

## II. $H_\infty$ CONTROLLER

Generally, the model has many uncertainties due to disturbances, parametric variations, noises and so on. Therefore, several robust control methods are available to solve above problems[3][11].  $H_\infty$  control theory can be one of the most powerful solutions for such problems. It is the method in control theory for optimal controller design.

It is known that the  $H_\infty$  control is an effective method for attenuating disturbances and noise that appear in the system. The “H” stands for Hardy space. “Infinity” means that it is designed to accomplish minmax restrictions in the frequency domain[3][11]. The  $H_\infty$  norm of a dynamic system is the maximum amplification that the system can make to the energy of the input signal[12]. In this paper, a method for discrete robust controller for an electromechanical fin servo system of a missile is presented. In the mixed sensitivity  $H_\infty$  design method, which utilizes the sensitivity function  $S(z)$  and the complementary sensitivity function  $T(z)$ . The mixed sensitivity  $H_\infty$  design method is expressed as:

$$S(z) + T(z) = I \tag{1}$$

Our aim is to find the discrete controller  $K$  that minimize the weighted sensitivity and weighted complementary sensitivity function over different frequency ranges.[10] This can be expressed in terms of linear fractional transformation  $F_l(P, K)$  where  $P$  is generalized plant i.e nominal plant and their weighting functions and  $K$  is controller. The block diagram is shown in Fig. 2.

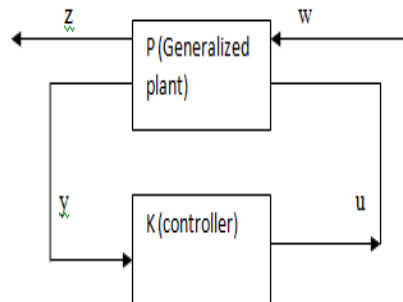

Fig. 1 Block diagram of linear fractional transformation

In fig.1., it shows the block diagram for the linear fractional transformation of the generalized plant with the robust controller.

Here, the generalized plant comprises of nominal plant and its associated weighting functions. The sensitivity weighting function given by  $W_1$ . This weighting function is used to limit the magnitude of the sensitivity function within a particular frequency range. This is performance function (measure) in the controller synthesis.[3][9]

Whereas the complimentary sensitivity weighting function given by  $W_2$ , which is used to limit the magnitude of  $T$  within particular frequency range. This is robustness weighting function in the controller synthesis.[3][9][12]

The weighting functions are such that the control performance specifications are satisfied as given in TABLE I.



# International Journal of Advanced Research in Electrical, Electronics and Instrumentation Engineering

(An ISO 3297: 2007 Certified Organization)

Vol. 4, Issue 6, June 2015

TABLE I: THE CONTROL PERFORMANCE OBJECTIVES FOR THE POSITION CONTROL

Rise time(sec)	Settling time(sec)	Overshoot%	Steady state error	Permissible input voltage
< 0.5 sec	< 1 sec	< 5%	< 1%	+/-10V

In table I, the required time domain performances for the plant with the controller are given. These are the objectives to be accomplished.

$$W_1 = \frac{(0.09)}{(z - 0.999)} \quad (2)$$

$$W_2 = \frac{(0.1z - 0.099)}{z} \quad (3)$$

So, the definition is modified as : to find the controller k such that the  $H_\infty$  norm of weighted sensitivity and weighted complementary functions are minimized over some frequency range[3] i.e.

$$\left\| \begin{matrix} W_1 S \\ W_2 T \end{matrix} \right\|_\infty = F_l(P, K)$$

is to be minimized.

### III. FREQUENCY-DOMAIN ROBUST CONTROLLER TOOLBOX

The Frequency-Domain Robust Controller Design Toolbox is a tool for designing robust linearly parameterized controllers in the Nyquist diagram[16][17]. It can be used to design linearly parameterized controllers of any order for parametric models or nonparametric models obtained for example by the identification toolbox of MATLAB[19]. The robust controllers are designed in terms of  $H_\infty$  performance or classical robustness margins such as the gain and phase margin, for single/multi-model, SISO/MIMO systems. The toolbox also supports designing gain-scheduled controllers.

In all of design cases, linear or convex optimization problems are solved[16]. For linear and quadratic optimization the well-known linprog or quadprog (depending on the problem) commands of the Optimization toolbox of MATLAB are used[17]. While convex optimization problems are formulated with YALMIP [21] and can be solved with all available solvers. Many commands of the Control toolbox of MATLAB are used as well. The procedure of design comprises three steps. First the type (or structure) of the controller is determined. Then the desired performance characteristics are specified, and finally a controller with the desired type and required performance is designed. In the following comes a brief description of these three steps with corresponding commands.

### IV. DESIGN EXAMPLE

The design model chosen for this case is of dc motor. The position of the dc motor is to be controlled using robust  $H_\infty$  controller. The discrete model is represented in state space form:



# International Journal of Advanced Research in Electrical, Electronics and Instrumentation Engineering

(An ISO 3297: 2007 Certified Organization)

Vol. 4, Issue 6, June 2015

$$\begin{bmatrix} x_1(k+1) \\ x_2(k+1) \end{bmatrix} = \begin{bmatrix} 1.939 & -0.939 \\ 1 & 0 \end{bmatrix} \begin{bmatrix} x_1(k) \\ x_2(k) \end{bmatrix} + \begin{bmatrix} 1 \\ 0 \end{bmatrix} u(k) \quad (4)$$

$$y(k) = \begin{bmatrix} 0 & 0.0039 \end{bmatrix} \begin{bmatrix} x_1(k) \\ x_2(k) \end{bmatrix}$$

Where  $u(k)$  and  $y(k)$  denote the model input and output respectively and  $x(k)$  is the state vector of the system at time instant  $k$ .

## V. SIMULATION AND RESULTS

### A. Design Of $H_\infty$ Controller

The robust  $H_\infty$  controller has been shown in table II. These pulse transfer functions have been found out from the frequency domain robust controller toolbox. In table, the time domain performance characteristics of the different order controllers have been compared. It can be seen that the overshoots of the 2<sup>nd</sup> order controller is 4.11% as compared to 3<sup>rd</sup> order controller which is 2%.

TABLE II: CONTROLLER OF DIFFERENT ORDERS

Order of controller	$K(z)$ ( $H_\infty$ controller transfer function)
2 <sup>nd</sup>	$\frac{42.3535(z - 0.9157)(z - 1.002)}{z(z - 1)}$
3 <sup>rd</sup>	$\frac{36.6246(z + 0.4913)(z - 0.946)(z - 1.002)}{z^2(z - 1)}$

In table II, the pulse transfer functions for different order of controllers are given which are found from the toolbox.

### B. Comparison Of Time Domain Characteristics Of Two Different Order Controllers

Now, the time domain characteristics of two different controllers based closed loop system are compared and analyzed as shown in table III. By reducing the order of the controller to 2, the response is still satisfactory. The advantage of 2<sup>nd</sup> order controller is that the cost and complexity is also reduced. The figure 2 shows the closed loop response for dc motor position control system. The two curves show the system with robust 2<sup>nd</sup> and 3<sup>rd</sup> order discrete controller.

TABLE III: PERFORMANCE SPECIFICATIONS

Characteristics	2 <sup>nd</sup> order	3 <sup>rd</sup> order
Rise time	0.52 seconds	0.01seconds
Settling time	3seconds	0.3seconds
Settling min	0.9364	0.01
Settling max	1.0411	0.23
Overshoot	4.11%	0%
Peak	1.0411	0.5
Peak time	1.9seconds	1seconds

In table III. The time domain performances are given for both the type of controllers with the plant.



# International Journal of Advanced Research in Electrical, Electronics and Instrumentation Engineering

(An ISO 3297: 2007 Certified Organization)

Vol. 4, Issue 6, June 2015

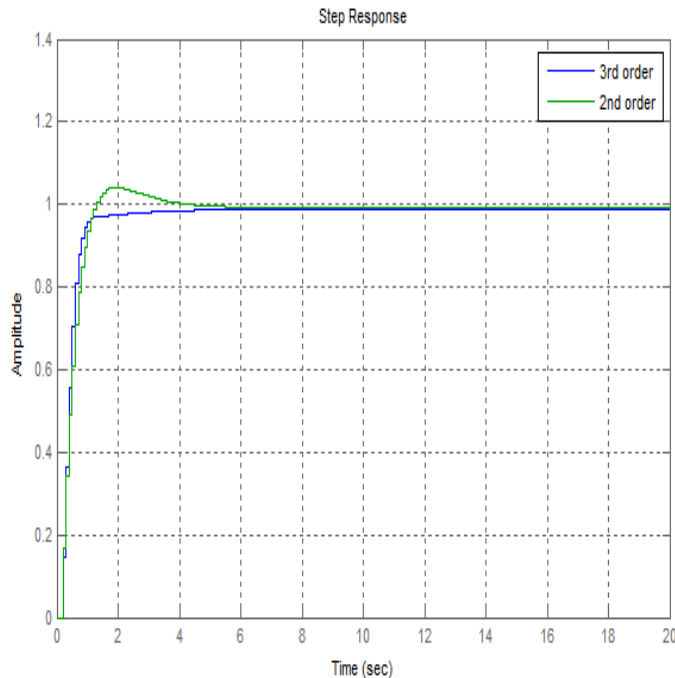

Fig 2 Step response of fixed order discrete controller for the dc motor position control

In fig.2., it shows the step response of fixed order i.e. 2<sup>nd</sup> and 3<sup>rd</sup> order discrete controller for the position control of the dc motor .

## VI. CONCLUSION

The modelling and design of a fixed order discrete time  $H_{\infty}$  controller for the DC motor position control has been demonstrated with available modelling and control synthesis. The results show that 3<sup>rd</sup> order as well as 2<sup>nd</sup> order controllers have attained all the desired performance with the simplest hardware requirements for implementation. The design has been executed by using Frequency Domain Robust Controller Toolbox.

## ACKNOWLEDGMENT

Thanks to my honorific guide Dr. Shiv Narayan, Professor, Department of Electrical Engineering, PEC University of technology, formerly Punjab Engineering College, Chandigarh with deepest gratitude, for giving the opportunities to perform research work under his able guidance.

## REFERENCES

- [1]. M. Safonov, D. Limebeer and R. Chiang, "Simplifying  $H_{\infty}$  Theory via Loop-shifting, Matrix Pencil and Descriptor Concepts", Int. J. Control, vol. 50, pp 2467-2488, 1989.
- [2] Engell, S, "Design of Robust Control Systems with Time-Domain Specifications", Control Engineering Practice, Vol. 13, No. 3, pp365-372,1995.
- [3] Hvostov, H.S., "Simplifying  $H_{\infty}$  Controller Synthesis Via Classical Feedback System Structure", IEEE Transactions on Automatic Control, Vol. 35, No. 4, pp485-488,1990.
- [4] Liu Tian-Hua and Liu Chang-Huan, "Implementation of AC Servo Controllers Employing Frequency-Domain Optimisation Techniques", IEEE Transaction on Industrial Electronics, Vol. 37, No 4, August 1990.



ISSN (Print) : 2320 – 3765  
ISSN (Online): 2278 – 8875

# International Journal of Advanced Research in Electrical, Electronics and Instrumentation Engineering

(An ISO 3297: 2007 Certified Organization)

Vol. 4, Issue 6, June 2015

- [5] LundstrOm, P., Skogestad, S. and Wang, Z-Q., "Performance Weight Selection For H-infinity and tt-eontml Methods", Transaction Institute of Measurement and Control, Vol. 13 No 5, pp241- 252,1990.
- [6] Chung-Hee Yoo, Young-Cheol Lee, and Sang-Yeal Lee," A Robust Controller for an Electro-Mechanical Fin Actuator", Proceeding of the 2004 American Control Conference Boston, Massachusetts, FrA03.6, June 30 - July 2, 2004.
- [7] Morari, M. and Zafwiou, E., "Robust Process Control", Prentice-Hall International Editions,1989.
- [8] Pith6, R., Pohlolalnen, S. and Virvalo, T., "Design of Robust Controllers For Position Servos Using H-infinity Theory", I.Mech.E. Journal of Systems and Control Engineering, Vol 4, No. 1, pp299-307,1991.
- [9] S. Panda, J. S. Yadav, N. P. Patidar and C. Ardil, "Evolutionary Techniques for Model Order Reduction of Large Scale Linear Systems", International Journal of Applied Science, Engineering and Technology, vol.5, no.1, pp. 22-28, 2009.
- [11] K. Zhou, and J. C. Doyle, "Essentials of robust control", Prentice Hall, 1998
- [12] D. McFarlane and K. Glover, "A loop shaping design procedure using  $H_\infty$  synthesis," IEEE Transactions on Automatic Control , vol. 31, no. 12, pp. 1799–1819, 1992.
- [13] J. C. Doyle, K. Glover, , P. P. Khargonekar, and B. A. Francis, "State space solutions to standard  $H_2$ and  $H_\infty$  control problem," IEEE Transactions on Automatic Control , vol. 34, no. 8, pp. 1228–1240, November 1989.
- [14] P. Gahinet and P. Apkarian, "A linear matrix inequality approach to  $H_\infty$ control," International Journal of Robust and Nonlinear Control, vol. 4, no. 4, pp. 421–448, 1994.
- [15] A. Karimi and G. Galdos, "Fixed-order  $H_\infty$  controller design for nonparametric models by convex optimization,"Automatica , vol. 46, no. 8, pp. 1388–1394, 2010.
- [16] A. Karimi, "Frequency-domain robust controller design: A toolbox for MATLAB," Automatic Control Laboratory, EPFL, Switzerland, 2012. [Online]. Available: [http://la.epfl.ch/FDRC Toolbox](http://la.epfl.ch/FDRC%20Toolbox).
- [17] G. Galdos, A. Karimi, and R. Longchamp, " $H_\infty$  controller design for spectral MIMO models by convex optimization,"Journal of Process Control , vol. 20, no. 10, pp. 1175 – 1182, 2010.
- [18] V. de Oliveira and A. Karimi, "Robust and gain-scheduled PID controller design for condensing boilers by linear programming," in IFAC Conference in Advances in PID Control , Brescia, Italy, 2012.
- [19] M. Sadeghpour, V. de Oliveira, and A. Karimi, "A toolbox for robust PID controller tuning using convex optimization," in IFAC Conference in Advances in PID Control , Brescia, Italy, 2012.
- [20] C. J. Doyle, B. A. Francis, and A. R. Tannenbaum, "Feedback Control Theory" . New York: Mc Millan, 1992.