



Writing Robotic Arm by Speech Recognition

K.S.Jadhav¹, Shilpa Madhav Gaikwad²

Head of the Department, Dept. of Electronics, Hi-Tech College Of Engineering, Aurangabad, India¹

PG Student [Electronics], Dept. of Electronics, SPW College of Engineering, Aurangabad, India²

ABSTRACT: Robotics is a key technology in the modern world. Robots are a well-established part of manufacturing and warehouse automation, assembling cars or washing machines, and, for example, moving goods to and from storage racks for Internet mail order. More recently robots have taken their first steps into homes and hospitals, and seen spectacular success in planetary exploration. Yet, despite these successes, robots have failed to live up to the predictions of the 1950s and 60s, when it was widely thought - by scientists and engineers as well as the public - that by turn of the 21st century we would have intelligent robots as butlers, companions, or co-workers. Robotics is the branch of mechanical engineering, electrical engineering and computer science that deals with the design, construction, operation, and application of robots, as well as computer systems for their control, sensory feedback, and information processing. These technologies deal with automated machines that can take the place of humans in dangerous environments or manufacturing processes, or resemble humans in appearance, behaviour, and/or cognition. Many of today's robots are inspired by nature contributing to the field of bio-inspired robotics. The concept of creating machines that can operate autonomously dates back to classical times, but research into the functionality and potential uses of robots did not grow substantially until the 20th century.

KEYWORDS: LPC 2148 Microcontroller, Mechanical assembly, SAPI (Speech Application Programming Interface).

I.INTRODUCTION

Robotics performs very important role in every field. Robotics brings together several very different engineering areas and skills. There is metalworking for the body. There is mechanics for mounting the wheels on the axles, connecting them to the motors and keeping the body in balance. You need electronics to power the motors and connect the sensors to the controllers. At last you need the software to understand the sensors and drive the robot around. Throughout history, robotics has been often seen to mimic human behaviour, and often manage tasks in a similar fashion. Today, robotics is a rapidly growing field, as technological advances continue; researching, designing, and building new robots serve various practical purposes, whether domestically, commercially, or militarily. Many robots do jobs that are hazardous to people such as defusing bombs, mines and exploring shipwrecks.



Fig. 1 Robotic arm

Robotics can be described as the current pinnacle of technical development. Robotics is a confluence science using the continuing advancements of mechanical engineering, material science, sensor fabrication, manufacturing techniques, and advanced algorithms. The study and practice of robotics will expose a dabbler or professional to hundreds of different avenues of study. For some, the romanticism of robotics brings forth an almost magical curiosity of the world

International Journal of Advanced Research in Electrical, Electronics and Instrumentation Engineering

(An ISO 3297: 2007 Certified Organization)

Vol. 4, Issue 6, June 2015

leading to creation of amazing machines. A journey of a lifetime awaits in robotics. Robotics can be defined as the science or study of the technology primarily associated with the design, fabrication, theory, and application of robots. In this project Robotic arms are programmed robot manipulator with similar functions of a human arm. Several kind of high technology prostheses are available for doing the basic functions of human arm. Aim of our project is to develop a robotic arm which helps the physically handicapped person to write. The robotic arm is to be fitted to the patient's amputee hand, and will write down the words that the patient pronounces to the microphone. The special feature of this robotic arm is that it is fitted with a pen which performs the writing operations.

II.LITERATURE REVIEW

The word robotics was derived from the word robot, which was introduced to the public by Czech writer Karel Capek in his play R.U.R. (Rossum's Universal Robots), which was published in 1920. The word robot comes from the Slavic word robota, which means labour. The literature is the development or progress of robotics in some last years, is as follows:

1954: The first programmable robot is designed by George Devol, who coins the term Universal Automation.

1969: Victor Scheinman at Stanford University invented the Stanford arm, an all electric, 6-axis articulated robot designed to permit an arm solution. This allowed the robot to accurately follow arbitrary paths in space and widened the potential use of the robot to more sophisticated applications such as assembly and arc welding.

1978: The Puma (Programmable Universal Machine for Assembly) robot is developed by Unimation with a General Motors design support.

1980s: The robot industry enters a phase of rapid growth. Many institutions introduce programs and courses in robotics. Robotics courses are spread across mechanical engineering, electrical engineering, and computer science departments.

1995: Emerging applications in small robotics and mobile robots drive 2nd growth of start-up companies and research.

2004: Staubli was still making articulated robots for general industrial and clean room applications.

III. SYSTEM DEVELOPMENT

Robotic arms are programmed robot manipulator with similar functions of a human arm. Several kind of high technology prostheses are available for doing the basic functions of human arm. Aim of our project is to develop a robotic arm which helps the physically handicapped person to write. The robotic arm is to be fitted to the patient's amputee hand, and will write down the words that the patient pronounces to the microphone. The special feature of this robotic arm is that it is fitted with a pen which performs the writing operations.

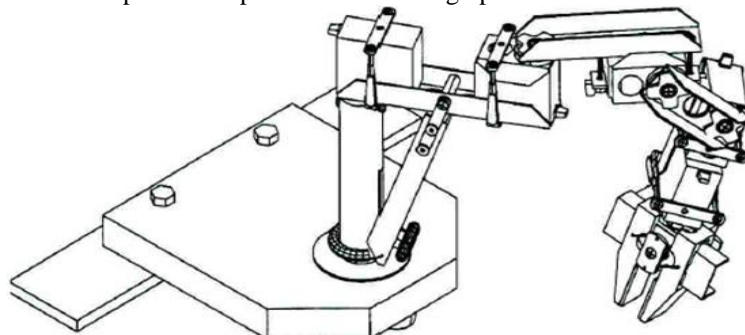

Fig. 2 Structure of Robotic arm

"Robotics is a field concerned with the intelligent connection of perception to action." A Robot is a reprogrammable manipulator designed to move material, parts, or specialized devices through various programmed motions for performing various tasks. The most common manufacturing robot is the robotic arm. A typical robotic arm is made up of seven metal segments, joined by six joints. The computer controls the robot by rotating individual step motors connected to each joint (some larger arms use hydraulics or pneumatics). The robotic arm that we have designed can be used by physically handicapped persons as a prosthetic limb, which help them in writing the words that they pronounce and as a future scope with advanced programming, the hand can be used to perform basic functions (holding, lifting, etc) controlled by speech. This will help in rehabilitating the handicapped persons back into society, they will be able to move freely and perform their daily activities with as much ease as the normal healthy individuals. A

International Journal of Advanced Research in Electrical, Electronics and Instrumentation Engineering

(An ISO 3297: 2007 Certified Organization)

Vol. 4, Issue 6, June 2015

Microphone is fitted to the robotic arm which acts as the input to for the speech signal from the user. The microphone receives the audio signals (speech signal).i.e. the word pronounced by the patient and converts it into an electrical form. A PC sound cord transfers this signal to a MATLAB TOOL BOX where the signal acquisition process takes place. Then this information is matched with the preprogrammed DSP algorithm, where signal text conversion takes place. This text then is transferred to a microcontroller unit via serial port (RS 232c).This microcontroller unit converts the text signal from the MATLAB toolbox into mechanical action. The microcontroller controls the stepper motors which in turn controls the movement of the pen connected with the robotic arm. The Programming and working of our robotic arm mainly consists of two parts. The first part involves receiving the speech signal from the user and converting it into a text form for further processing and second part consists of using this text data to obtain a suitable required mechanical action of the motors.

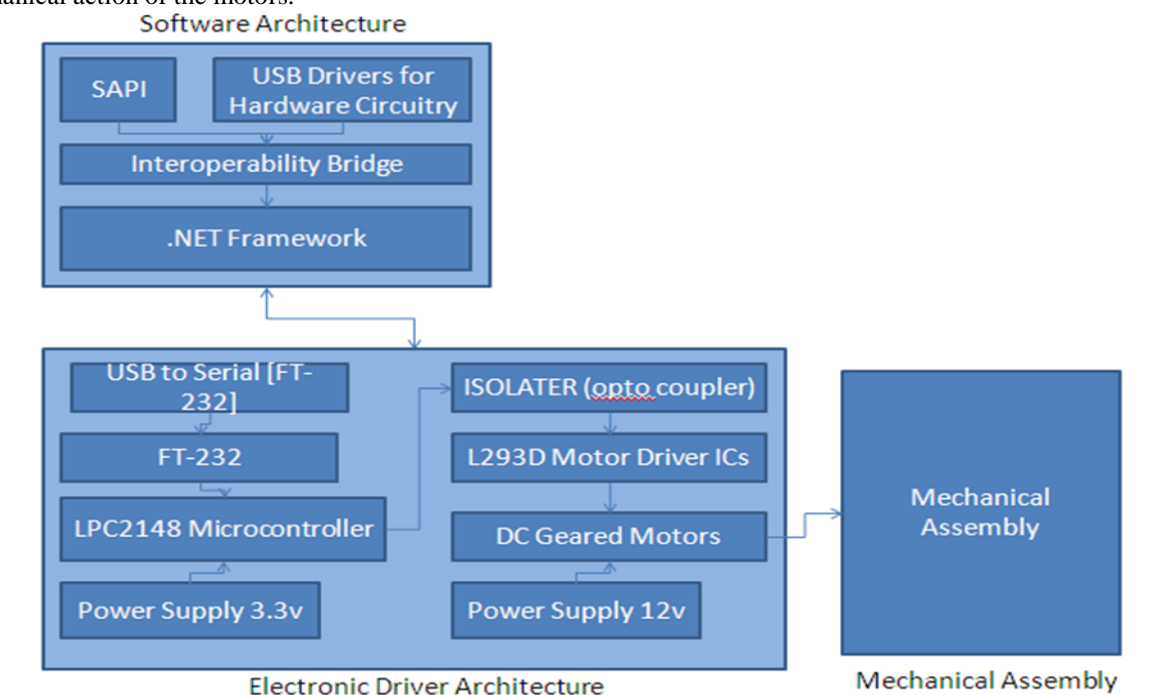

Fig. 3 Block diagram

The figure 3 shows the general block diagrams of robotic arm. This consists of three basic units that is software architecture, electronic driver architecture and the mechanical assembly.

A. Software architecture:

In software system we have used interoperability which creates bridge between regular .net language and our usb serial driers to communication with hardware. That bridge is required because driver support is having windows functionality and .NET architecture has its own. SAPI is a set of regular API's(functions library). Which helps us to perform speech related operations. In SAPI we can create grammar or we can directly extract words those are spoken by user and perform operations over those words.

- Interoperability: It describes how .NET components can communicate with existing COM components without migrating those COM components into .NET components.
- Speech Application Programming Interface (SAPI) :The Speech Application Programming Interface or SAPI is an API developed by Microsoft to allow the use of speech recognition and speech synthesis within Windows applications. Broadly the Speech API can be viewed as an interface or piece of middleware which sits between applications and speech engines (recognition and synthesis). In SAPI versions 1 to 4, applications could directly communicate with engines. The API included an abstract interface definition which applications and engines conformed to. Applications could also use simplified higher-level objects rather than directly call methods on the engines.

International Journal of Advanced Research in Electrical, Electronics and Instrumentation Engineering

(An ISO 3297: 2007 Certified Organization)

Vol. 4, Issue 6, June 2015

- .NET Framework: The Microsoft .Net Framework is a platform that provides tools and technologies you need to build Networked Applications as well as Distributed Web Services and Web Applications. The .Net Framework provides the necessary compile time and run-time foundation to build and run any language that conforms to the Common Language Specification (CLS).The main two components of .Net Framework are Common Language Runtime (CLR) and .Net Framework Class Library (FCL).The Common Language Runtime (CLR) is the runtime environment of the .Net Framework, that executes and manages all running code like a Virtual Machine. The .Net Framework Class Library (FCL) is a huge collection of language-independent and type-safe reusable classes. The .Net Framework Class Libraries (FCL) is arranged into a logical grouping according to their functionality and usability is called Namespaces.

B. Electronic driver architecture:

We are suppose to use two DC geared motors to drive robotic arm in operating all directions and maximum area (as above 180⁰).Two motors needs one L293D and to drive four we are using two L293D. We are having 2 different types of power supplies one is of 3.3 volts for LPC2148 (ARM Microcontroller) and another 12v. for Motor driver. L293D works similar to relay architecture. We use DC Geared so that it performs each operation in a specific angle which helps us to calculate degree and direction in proper manner. FT-232 is a USB to serial converter IC.

- LPC2148 Microcontroller:

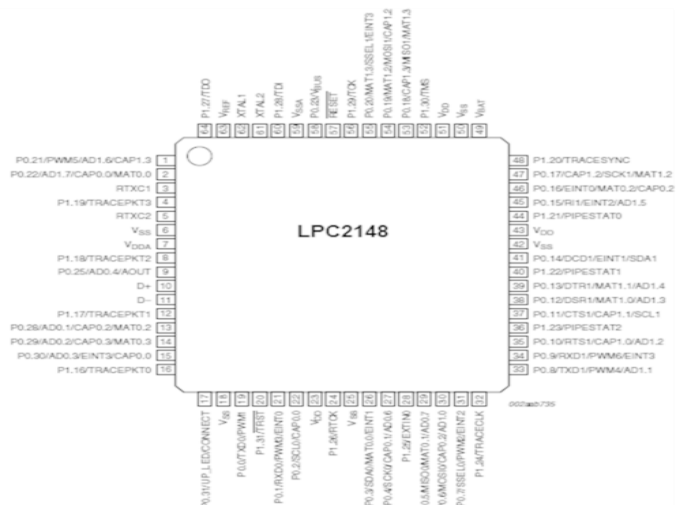

Fig. 4 LPC2148Microcontroller

Figure 4 shows the pin diagram of LPC 2148 ARM 7 based Microcontroller.LPC2148 is the widely used IC from ARM-7 family. It is manufactured by Philips and it is pre-loaded with many inbuilt peripherals making it more efficient and a reliable option for the beginners as well as high end application developer. ARM7 LPC2148 Microcontroller Socket is used with LPC2148 Pro Development Board. It is a standalone board for LPC2148 microcontroller. It has 12MHz crystal for system clock and 32KHz crystal for RTC. It has power on reset circuit with MCP130T brownout monitoring chip and power decoupling capacitors. This board can be used for LPC2148 based generic development. The heart of the circuit is microcontroller, here we used LPC2148 ARM based Microcontroller.

- OptoCouplers: In electronics, an opto-isolator, also called an optocoupler, photo coupler, or optical isolator, is a component that transfers electrical signals between two isolated circuits by using light. Opto-isolators prevent high voltages from affecting the system receiving the signal. Commercially available opto-isolators withstand input-to-output voltages up to 10 kV and voltage transients with speeds up to 10 kV/μs. A common type of opto-isolator consists of an LED and a phototransistor in the same opaque package. Other types of source-sensor combinations include LED-photodiode, LED-LASCR, and lamp-photo resistor pairs. Usually opto-isolators transfer digital (on-off) signals, but some techniques allow them to be used with analog signals. An opto-isolator contains a source (emitter) of light, almost always a near infrared light-emitting diode (LED), that converts electrical input signal into light, a closed optical channel (also called dialectical channel), and a photo sensor, which detects incoming light and either generates

International Journal of Advanced Research in Electrical, Electronics and Instrumentation Engineering

(An ISO 3297: 2007 Certified Organization)

Vol. 4, Issue 6, June 2015

electric energy directly, or modulates electric current flowing from an external power supply. The sensor can be a photo resistor, a photodiode, a phototransistor, a silicon-controlled rectifier (SCR) or a triac.

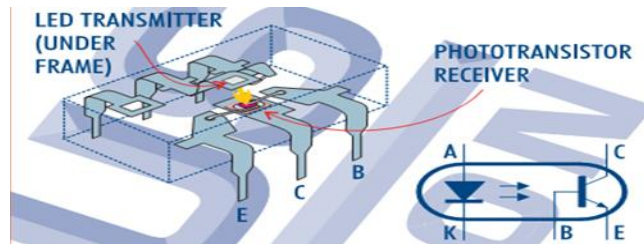

Fig. 5 OptoCouplers

Because LEDs can sense light in addition to emitting it, construction of symmetrical, bidirectional opto-isolators is possible. An optocoupled solid state relay contains a photodiode opto-isolator which drives a power switch, usually a complementary pair of MOSFETs. A slotted optical switch contains a source of light and a sensor, but its optical channel is open, allowing modulation of light by external objects obstructing the path of light or reflecting light into the sensor.

- L293D:

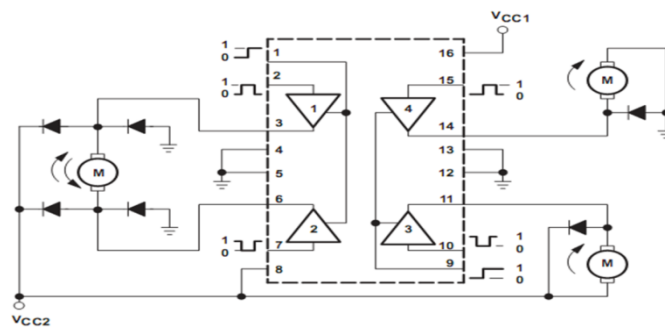

Fig. 6 L293D

Figure 6 shows the L293D circuit diagram. This is quadruple high current half-H drivers. The L293 is designed to provide bidirectional drive currents of up to 1 A at voltages from 4.5 V to 36 V. The L293D is designed to provide bidirectional drive currents of up to 600-mA at voltages from 4.5 V to 36 V. Both devices are designed to drive inductive loads such as relays, solenoids, dc and bipolar stepping motors, as well as other high-current/high-voltage loads in positive-supply applications. All inputs are TTL compatible. Each output is a complete totem-pole drive circuit, with a Darlington transistor sink and a pseudo-Darlington source. Drivers are enabled in pairs, with drivers 1 and 2 enabled by 1,2EN and drivers 3 and 4 enabled by 3,4EN. When an enable input is high, the associated drivers are enabled and their outputs are active and in phase with their inputs. When the enable input is low, those drivers are disabled and their outputs are off and in the high-impedance state. With the proper data inputs, each pair of drivers forms a full-H (or bridge) reversible drive suitable for solenoid or motor applications. On the L293, external high-speed output clamp diodes should be used for inductive transient suppression. A V_{CC1} terminal, separate from V_{CC2}, is provided for the logic inputs to minimize device power dissipation. The L293 and L293D are characterized for operation from 0 ° C to 70 ° C. L293D is a typical Motor driver or Motor Driver IC which allows DC motor to drive on either direction. L293D is a 16-pin IC which can control a set of two DC motors simultaneously in any direction. It means that you can control two DC motor with a single L293D IC. Dual H-bridge Motor Driver integrated circuit (IC).

- DC geared motor: Geared DC motors can be defined as an extension of DC motor which already had its Insight details demystified here. A geared DC Motor has a gear assembly attached to the motor. The speed of motor is counted in terms of rotations of the shaft per minute and is termed as RPM. The gear assembly helps in increasing the torque and reducing the speed. Using the correct combination of gears in a gear motor, its speed can be reduced to any desirable figure. This concept where gears reduce the speed of the vehicle but increase its torque is known as gear reduction. This Insight will explore all the minor and major details that make the gear head and hence the working of geared DC motor. A gear motor is a type of electrical motor. Like all electrical motors, it uses the magnetism induced by an electrical current to rotate a rotor that is connected to a shaft. The energy transferred from the rotor to the shaft is

International Journal of Advanced Research in Electrical, Electronics and Instrumentation Engineering

(An ISO 3297: 2007 Certified Organization)

Vol. 4, Issue 6, June 2015

then used to power a connected device. In a gear motor, the energy output is used to turn a series of gears in an integrated gear train. There are a number of different types of gear motors, but the most common are AC (alternating current) and DC (direct current).

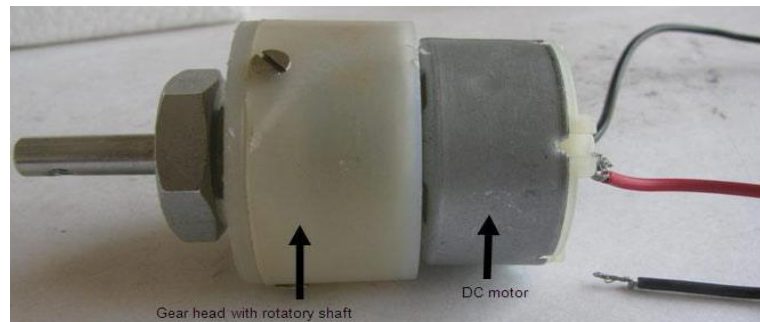

Fig. 7 DC Geared motor

In a gear motor, the magnetic current (which can be produced by either permanent magnets or electromagnets) turns gears that are either in a gear reduction unit or in an integrated gear box. A second shaft is connected to these gears. The result is that the gears greatly increase the amount of torque the motor is capable of producing while simultaneously slowing down the motor's output speed. The motor will not need to draw as much current to function and will move more slowly, but will provide greater torque.

C. Mechanical assembly:

The third and very important part of the robotic arm is mechanical assembly by which the mechanical movement of the robotic arm is carried out. After the software, Programming part there is an electronic driver part in which working of microcontroller, dc motor and motor driver IC is carried out. The mechanical assembly part is completely dependent on mechanical movement of the arm. A Microphone is fitted to the robotic arm which acts as the input to for the speech signal from the user. The microphone receives the audio signals (speech signal).i.e. the word pronounced by the patient and converts it into an electrical form. A PC sound cord transfers this signal to a MATLAB TOOL BOX where the signal acquisition process takes place. Then this information is matched with the pre-programmed DSP algorithm, where signal text conversion takes place. This text then is transferred to a microcontroller unit via serial port. This microcontroller unit converts the text signal from the MATLAB toolbox into mechanical action.



Fig. 8 Mechanical movement of robotic arm

The above figure 8 shows the Mechanical movement of robotic arm in this microcontroller controls the stepper motors which in turn controls the movement of the pen connected with the robotic arm. The Programming and working of our robotic arm mainly consists of two parts. The first part involves receiving the speech signal from the user and converting it into a text form for further processing and second part consists of using this text data to obtain a suitable required mechanical action of the motors.

International Journal of Advanced Research in Electrical, Electronics and Instrumentation Engineering

(An ISO 3297: 2007 Certified Organization)

Vol. 4, Issue 6, June 2015

IV. RESULT AND DISCUSSION

The project proposed by me, to design a writing robotic arm showing by speech recognition was successfully designed and working of it was checked successful output. This work included the conversion of this text data into a mechanical action by using a microcontroller. The aim of this project is to help the physically handicapped persons to write.

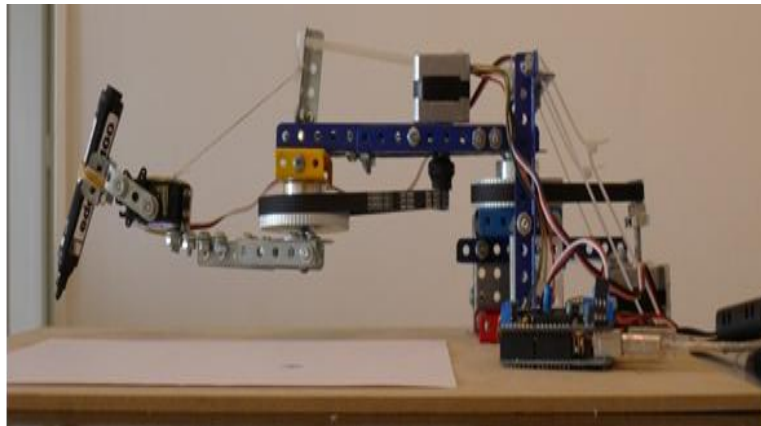

Fig. 9 Writing Robotic Arm by Speech Recognition

The patients who are physically handicapped, those who could not write by their hands, my project will definitely help this patients to write with the help of robotic arm by speech recognition. The above figure 9 shows the design and implementation of the writing robotic arm by speech recognition.

V. CONCLUSION

Robots, like computers, are powerful tools that open horizons to their human creators. They do not tire, and can stand up to environmental conditions that we cannot endure. In my senior design project, I have used the robotic arm to demonstrate speech recognition and writing skills of robot.

The insertion control device demonstrated the usefulness of passive compliance devices in assembling tasks by compensating for any misalignment between the mating parts. In addition, performing such tasks using robots avoid the passive repetition of the movement that would bore a person assigned to the task and minimize human errors throughout the process. Meanwhile, the XR-4 robotic arm is able to perform the task continuously without tiring and with minimal errors. The force control device proposed can provide a suitable solution in robotic applications in industry where a constant amount of force onto a surface contact is required to accomplish a task, such as polishing a surface. Requirements for such a task would be impractical for a person to carry out since it is impossible for a person to gauge and maintain the amount of force that is applied onto a surface. Therefore active force feedback control devices are usually used in industries. With the advancement of robotic technology, more tasks are being performed by robots to reduce the execution time and minimize human errors, such as slips caused by exhaustion and negligence. Finally, as the technology improves, there will be new ways to use robots which will bring new hopes and new potentials. Robots are becoming more and more useful in hospitals. They not only perform many of the more mundane chores, but some are quite capable of acting as nurses' assistants. Utilization of robots also reduces downtime by performing a task continuously until it is shut down for maintenance or at the completion of the assigned task. Robots have been used before to interact with children, elderly, and autistic patients, all of whom appreciate the attention that in some instances only a robot is in a position to give

ACKNOWLEDGEMENT

Whenever we are standing on most difficult step of the dream of our life we often remind about the great God for his blessings and kind help and he always help us in tracking off the problems by some means in our lifetime. I feel great pleasure to present this seminar entitled "WRITING ROBOTIC ARM BY SPEECH RECOGNITION". I am grateful to those people who help me a lot. It is their support and blessings, which has brought me to write this project report. I have a deep sense of gratitude in my heart for them.



International Journal of Advanced Research in Electrical, Electronics and Instrumentation Engineering

(An ISO 3297: 2007 Certified Organization)

Vol. 4, Issue 6, June 2015

I would give sincere thanks to our honourable head of department, Prof. K. S. Jadhav who has been and will be source of inspiration to me. I am thankful to my respected guide Prof. K. S. Jadhav for his whole hearted support and affectionate encouragement without which my successful seminar would not have been completed. I m also thankful to my honourable principal Prof. P. R. Thorat for giving me support and creating healthy environment to learn our best possible way. Finally, I m very grateful to mighty God and inspiring parents whose loving and caring support contributed a major share in completion of my task.

REFERENCES

- [1] Rosheim, Mark E. "Robot Evolution: The Development of Anthropotics." Wiley-IEEE. pp. 9– 10. ISBN 0-471-02622-0.1994.
- [2] Nocks, Lisa. The robot : the life story of a technology. Westport, CT: Greenwood Publishing Group. 2007
- [3] Zunt, Dominik. "Who did actually invent the word "robot" and what does it mean?". The Karel Capek website. Retrieved 2007-09-11.
- [4] Asimov, Isaac . "The Robot Chronicles". Gold. London: Voyager. pp. 224–225. ISBN 0-00- 648202-3.1995-1996.
- [5] Fowler, Charles B. "The Museum of Music: A History of Mechanical Instruments".Music Educators Journal 54(2): 4549. doi:10.2307/3391092 .JSTOR 3391092. October 1967.
- [6] Billing, Rius; Fleischner, Richard. "Mars Science Laboratory Robotic Arm". 15th European Space Mechanisms and Tribology Symposium 2011. Retrieved 2012-08-21.
- [7] T. N. Hornyak. "Loving the Machine: The Art and Science of Japanese Robots." Kodansha International. 2006.
- [8] Assembleon. "SMT pick-and-place equipment". Archived from the original on 2008-08-03. Retrieved 2008-09-21.
- [9] R.P. Lippmann. "Review of neural networks of speech recognition", Neural computation, v1 (1), pp 1-38, 1989
- [10] Ashraf Elfasakhany, Eduardo Yanez, Karen Baylon, Ricardo Salgado, "Design and Development of a Competitive Low-Cost Robot Arm with Four Degrees of Freedom". Modern Mechanical Engineering, 1, November 2011, 47-55.2011.

BIOGRAPHY



NAME: SHILPA M. GAIKWAD
PG Student,
Department of Electronics,
Savitribai Phule Women's Engineering College,
Maharashtra, INDIA



NAME: K. S. JADHAV
Head of the Department,
Department of Electronics,
Hi-Tech Engineering College,
Maharashtra, INDIA