



Power Quality Improvement Using Unified Power Quality Conditioner Based On Phase-Locked Loop

C.K.Ponnusamy¹, P.Madasamy², K.Ramadas³, M.Arun⁴

Assistant Professor, Department of Electrical and Electronics Engineering, Jayaram Engineering College, Trichy, Tamil Nadu, India¹

Assistant Professor, Department of Electrical and Electronics Engineering, Alagappa Chettiar College of Engineering and Technology, Karaikudi, Tamil Nadu, India^{2,3}

Assistant Professor, Department of Electrical and Electronics Engineering, Annamalai University, Tamil Nadu, India⁴

ABSTRACT: This project presents a power quality improvement using unified power quality conditioner (UPQC) to compensate current and voltage quality problems of sensitive loads. The UPQC consists of the series and shunt converter having a common dc link. The series converter mitigates voltage sag from the supply side and shunt converter eliminates current harmonics from the non-linear load side. The developed controllers for series and shunt converters are based on a reference signal generation method (phase-locked loop). The dc link control strategy is based on the fuzzy-logic controllers. The conventional method using dq transformation to show the superiority of the proposed sag detection method. A fast sag detection method is also presented. The efficiency of the proposed system is tested through simulation studies using the MATLAB/SIMULINK environment.

KEYWORDS: unified power quality conditioner (UPQC), reference signal generation, active filter, fuzzy-logic controller.

I. INTRODUCTION

Power quality is the set of limits of electrical properties that allows electrical systems to function in their intended manner without significant loss of performance or life. The term is used to describe electric power that drives an electrical load and the load's ability to function properly with that electric power. Without the proper power, an electrical device (or load) may malfunction, fail prematurely or not operate at all. There are many ways in which electric power can be of poor quality and many more causes of such poor quality power. With the increasing applications of nonlinear and electronically switched devices in distribution systems and industries, Power quality (PQ) problems, such as harmonics, flicker, and imbalance have become serious concerns. In addition Lighting strikes on transmission lines, switching of capacitor banks, and various network faults can also cause PQ problems, such as transients, voltage sag and interruption [1].

Voltage-source converter (VSC)- based custom power (CP) devices are increasingly being used in custom power applications to mitigate these PQ problems in power distribution systems. A shunt converter (also known as the shunt active filter) can compensate for distortion and unbalance in a load so that a balanced sinusoidal current flows through the feeder. A series converter (also known as the dynamic voltage) can compensate for voltage sag and distortion in the supply side voltage so that the voltage across a sensitive load is perfectly regulated. Control techniques play a vital role in the overall performance of the power conditioner.

Instantaneous power theory is generally preferred to generate reference signals for the shunt converter [3]. An extended method based on instantaneous reactive power theory in a rotating reference frame is used to suppress the harmonics and to correct the power factor in [4]. Fuzzy logic is utilized to control the compensation currents of the shunt converter in [5].

International Journal of Advanced Research in Electrical, Electronics and Instrumentation Engineering

(An ISO 3297: 2007 Certified Organization)

Website: www.ijareeie.com

Vol. 4, Issue 12, December 2015

There has also been interest in the circuit topologies of UPQC. UPQC is generally designed as three-phase three-wire (3P3W) systems. The three-phase four-wire system is also realized from the system where the neutral of series transformer used in series part UPQC is considered as the fourth wire for the 3P3W system. There are also single phase UPQC system. Various topologies, such as H-bridge converters, and single-phase UPQC with three legs are examined for the UPQC applications.

This paper presents novel contributions for UPQC control and has the following functions:

- The new control approach based on enhanced phase-locked loop and a nonlinear adaptive filter for reference signals generation is derived for series and shunt converters analyzed.
- A fuzzy logic controller (FLC) in MATLAB to control dc-link voltage without any interfacing of other simulation programs.
- FLC of dc-link voltage is proposed which improves the current total harmonic distortion (THD) over the conventional PI controller.
- A fast algorithm for sag detection is also presented.

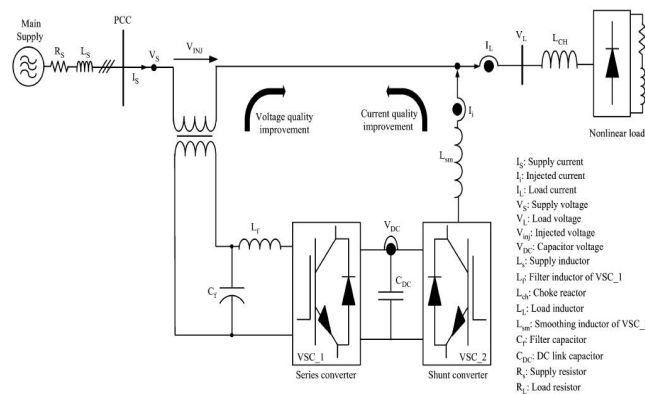

Fig. 1. Schematic diagram of UPQC.

The remainder of this paper is organized as follows. Section II of this paper presents a power circuit configuration of UPQC. Section III and IV, the controller algorithms of series and shunt converters are presented. In section V effectiveness of the proposed UPQC is tested.

II. POWER CIRCUIT CONFIGURATION OF UPQC

The UPQC shown in Fig. 1 consists of two VSCs (VSC_1 and VSC_2) that are connected back to back through common energy storage dc capacitor (C_{DC}). Series converter (VSC_1) is connected through transformers between the supply and point of common coupling (PCC). Shunt converter (VSC_2) is connected in parallel with PCC through the transformers. VSC_1 operates as a voltage source while VSC_2 operates as a current source.

The main objective of VSC_1 is to mitigate voltage sag from the supply side. The ac filter inductor L_f and capacitor C_f are connected in each phase to prevent the flow of harmonics currents generated due to switching [2]. The objective of VSC_2 are to regulate the dc link voltage between both converters and to suppress the load current harmonics [6]. The switching devices in VSC_1 and VSC_2 are insulated-gate bipolar transistors (IGBT) with anti parallel diodes. C_{dc} provides the common dc-link voltage to VSC_1 and VSC_2 . The proposed UPQC system offers two mode of operation as follows.

- VSC_1 off and VSC_2 on: When the PCC voltage is within its operation limits, VSC_1 is closed and VSC_2 works as the current source. VSC_2 suppress the load current harmonics and regulate dc-link voltage during this mode of

International Journal of Advanced Research in Electrical, Electronics and Instrumentation Engineering

(An ISO 3297: 2007 Certified Organization)

Website: www.ijareeie.com

Vol. 4, Issue 12, December 2015

operation.

- VSC₁ on and VSC₂ on: When the PCC voltage is outside its operating range; both VSC₁ and VSC₂ are open. VSC₁ starts to mitigate sag using energy stored in V_{DC} and VSC₂ continue to suppress the load current harmonics and to regulate dc-link voltage. Ideally once charged, the dc-link voltage V_{DC} should not fall off its charge, but due to finite switching losses of the inverter.

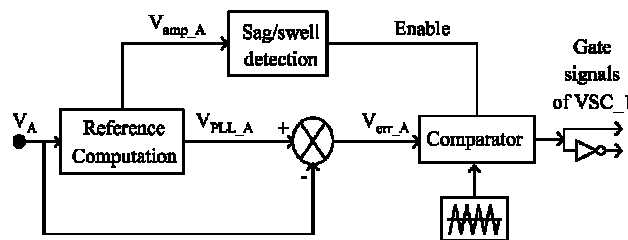

Fig. 2. Control block diagram of the series converter.

III. SERIES CONVERTER CONTROL

The series converter includes the reference voltage and sag detection method. Fig. 2 shows the control algorithm of a series converter for phase A. This control algorithm is identical for the other phases.

A. Reference Voltage Generation

A block diagram of the proposed algorithm is shown in the Fig. 3. The proposed controller algorithm is derived from the findings of both enhanced PLL and nonlinear adaptive filter. The proposed controller minimizes the mathematical operands in the system and reduces complex parameter tuning. The measurements of supply voltages are required for the control strategy of VSC₁.

The system receives the measured input signal $A(t)$ and provides an online estimate of the following signals:

1. $B(t)$, the difference of input and the synchronized Fundamental component;
2. $C(t)$, the amplitude of $D(t)$;
3. $D(t)$, the synchronized fundamental component;
4. $E(t)$, PLL signal;
5. $\Theta(t)$, the phase angle of $D(t)$.

For the series converter, $A(t)$ corresponds to the supply voltage V_A , and $E(t)$ corresponds to V_{PLL-A} as shown from the Figs. The required compensation signal V_{err-A} is obtained from $(V_{PLL-A} - V_A)$. $C(t)$ corresponds to V_{amp_a} and this signal is used to detect the voltage sag.

The supply voltage and its extracted components, such as the difference of input and the synchronized fundamental component $B(t)$, the amplitude $C(t)$, synchronized fundamental component.

International Journal of Advanced Research in Electrical, Electronics and Instrumentation Engineering

(An ISO 3297: 2007 Certified Organization)

Website: www.ijareeie.com

Vol. 4, Issue 12, December 2015

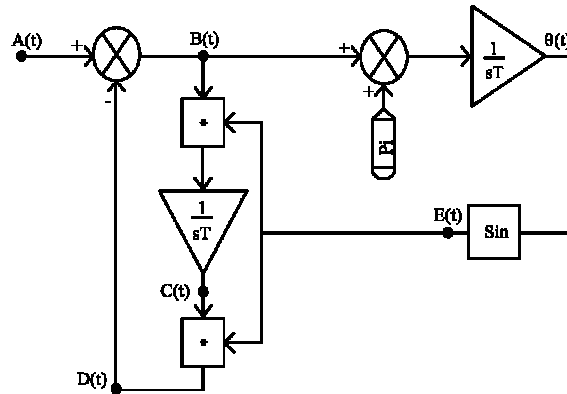

Fig. 3. Block diagram of the proposed algorithm.

B. Sag Detection Method

The proposed sag detection method is compared with the conventional method using dq transformation to show the superiority of the proposed detection method.

1. Conventional method:

The phase voltages V_a , V_B , V_C are transformed to the dq

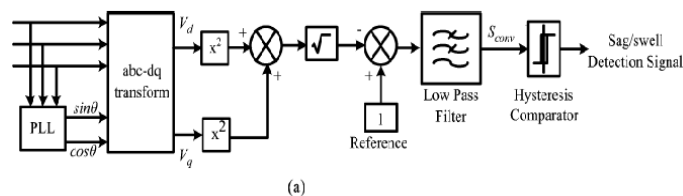

Fig. 4. (a) Conventional Method

Plane as given with the sag is obtained in the conventional method. In fig. 4.(a), the block diagram of the dq transformation- based sag detection method is shown. After the three-phase set of voltages is transformed into d and q components, the square root of the sum of square of these components is obtained.

The obtained value is subtracted from the 1 (reference value) and then the absolute value of the resulting variable is filtered out with a 100-Hz low-pass filter to extract the positive- sequence component of voltage. If the negative sequence is generated by voltage sag or unbalance, it appears as an oscillating error in the dq- based sag detection method.

The filtered output is subjected to a hysteresis comparator, and the output of this comparator generates the sag detection signal. The signal is high when sag occurs and is low otherwise. The most important disadvantage of this method is that it uses three-phase voltage measurements for the detection.

International Journal of Advanced Research in Electrical, Electronics and Instrumentation Engineering

(An ISO 3297: 2007 Certified Organization)

Website: www.ijareeie.com

Vol. 4, Issue 12, December 2015

2. Proposed Method:

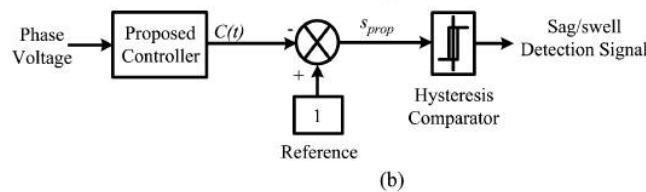

Fig. 4.(b) Proposed sag detection method.

The voltage sag detection method using PLL by subtracting the $C(t)$ signal from the ideal voltage magnitude (1 p.u), the voltage sag depth can be detected. The comparison of this value with the limit value of 10% (0.1p.u) gives information as to whether voltage sag occurred. In fig. 4.b. the voltage sag are detected within a few milliseconds. The conventional method cannot detect the sag, but the proposed method can detect the depth with exact certainty. The single- phase voltage sag initiates at 0.3s with duration of 0.1s .The proposed method detect the voltage sag and balance without error.

IV.SIMULATION RESULTS AND DISCUSSION

The power quality improvement capability of the UPQC system is tested through MATLAB. A three phase diode bridge rectifier is used as a harmonic current producing load with a total harmonic distortion (THD) of 14.21%.

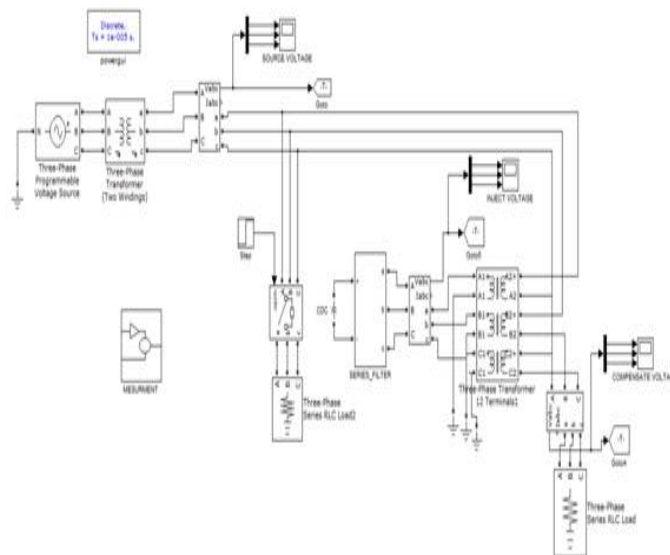

Fig. 5 Test System With Series Converter.

International Journal of Advanced Research in Electrical, Electronics and Instrumentation Engineering

(An ISO 3297: 2007 Certified Organization)

Website: www.ijareeie.com

Vol. 4, Issue 12, December 2015

V. SIMULATION RESULTS ON SERIES CONVERTER

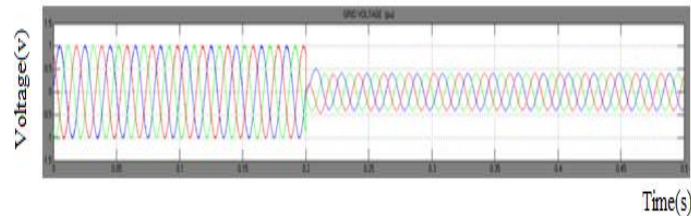

(a)

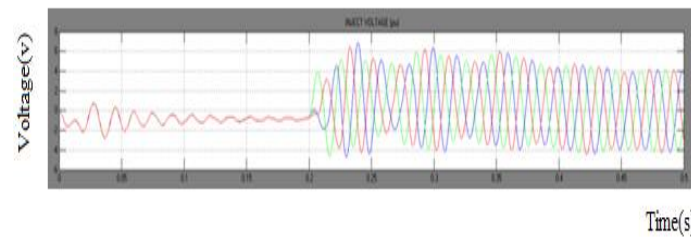

(b)

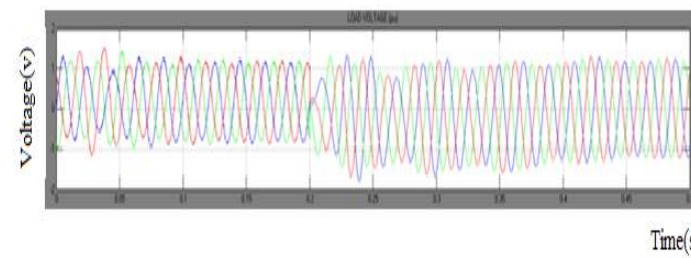

(c)

5(a). Source voltage under the voltage sag condition.

5(b). Injecting voltage.

5(c). Load voltage.

VI. DC-LINK CAPACITOR VOLTAGE

V_{dc} is nearly kept at 750 V_{dc} before the voltage sag. Switching losses and the power received from the V_{dc} through the series converter. The V_{dc} value almost at 750 V_{dc} during the sag in shown in the fig. 6.

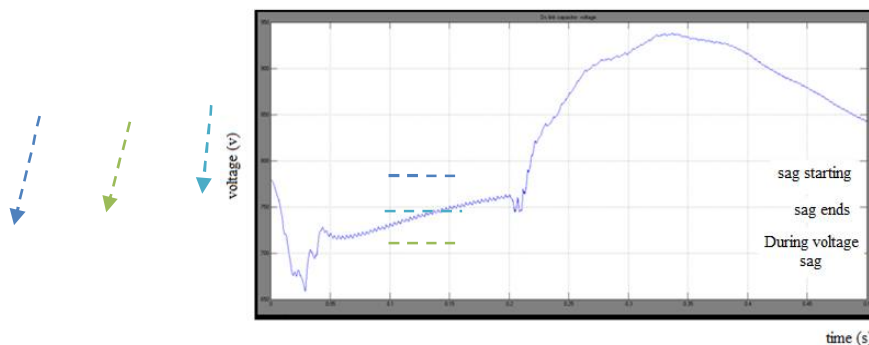

Fig. 6. Variation of the dc-link capacitor voltage before and during the 20% of voltage sag.

International Journal of Advanced Research in Electrical, Electronics and Instrumentation Engineering

(An ISO 3297: 2007 Certified Organization)

Website: www.ijareeie.com

Vol. 4, Issue 12, December 2015

VII.SIMULATION RESULTS ON SERIES CONVERTER

EACH PHASE(A,B,C)

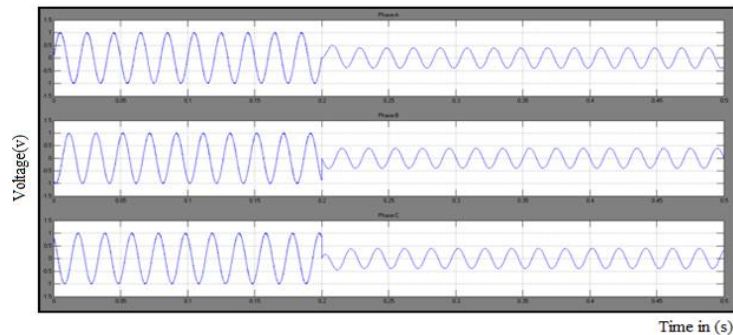

(a)

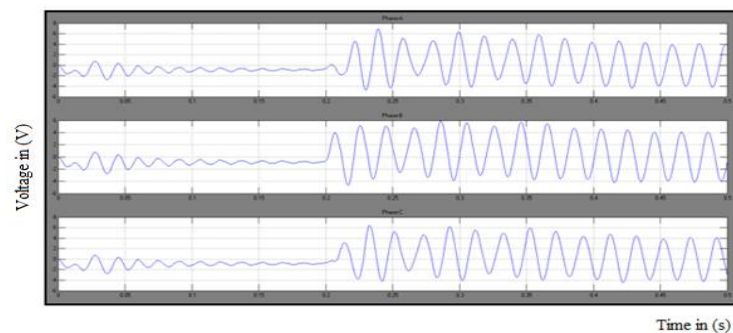

(b)

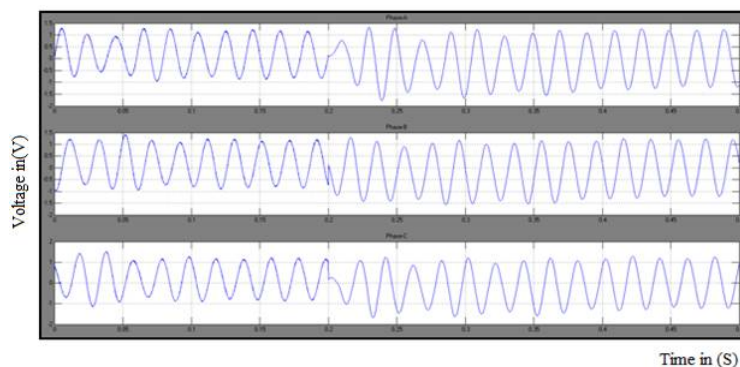

(c)

- 7(a). Grid voltage
- 7(b). Inject voltage
- 7(c).Compensating voltage

Simulation results on series converter the performance of VSC₁ from the points of view of voltage sag detection method speed, sag compensation, and harmonic suppression capabilities are to be achieved.



International Journal of Advanced Research in Electrical, Electronics and Instrumentation Engineering

(An ISO 3297: 2007 Certified Organization)

Website: www.ijareeie.com

Vol. 4, Issue 12, December 2015

VIII. CONCLUSION

The unified power quality conditioner is introduced and analyzed by the controlling voltage source converter (VSC₁) based on enhanced PLL and nonlinear adaptive filter algorithms and dc-link voltage with a fuzzy logic controller. New functionality is added to the UPQC system to quickly extract the reference signals directly for load current and supply voltage with a minimal amount of mathematical operands. The number of parameters to be tuned has also been reduced by the use of the proposed controller. The performance of the proposed UPQC and controller for the PQ improvement is tested through the simulations. The proposed UPQC system provides simultaneous mitigation of a variety of PQ problems.

REFERENCES

- [1] H. R. Mohammadi, A. Y. Varjani, and H. Mokhtari, "Multiconverter unified power quality conditioning system MC-UPQC," IEEE Trans. Power Del., vol. 24, no. 3, Jul. 2009, pp. 1679–1686.
- [2] A. K. Jindal, A. Ghosh, and A. Joshi, "Interline unified power quality conditioner," IEEE Trans. Power Del., vol. 22, no. 1, Jan. 2007, pp. 364–372.
- [3] H. Fujita and H. Akagi, "The unified power quality conditioner: The integration of series and shunt-active filters," IEEE Trans. Power Electron., vol. 13, no. 2, Mar. 1998, pp. 315–322.
- [4] M. Brenna, R. Faranda, and E. Tironi, "A new proposal for power quality and custom power improvement OPEN UPQC," IEEE Trans. Power Del., vol. 24, no. 4, Oct. 2009, pp. 2107–2116.
- [5] A. Ghosh and G. Ledwich, "A unified power quality conditioner (UPQC) for simultaneous voltage and current compensation," Elect. Power Syst. Res., vol. 59, 2001, pp. 55–63.
- [6] L. Qian, D. A. Cartes, and H. Li, "An improved adaptive detection method for power quality improvement," IEEE Trans. Ind. Appl., vol. 44, no. 2, Mar./Apr. 2008, pp. 525–533.
- [7] H. S. Song, H. G. Park, and K. Nam, "An instantaneous phase angle detection algorithm under unbalanced line voltage condition," in Proc. IEEE Power Electron. Specialis. Conf., 1999, vol. 1, pp. 533–537.
- [8] B. Wu and M. Bodson, "A magnitude/phase-locked loop approach to parameter estimation of periodic signals," IEEE Trans. Autom. Control, vol. 48, no. 4, Apr. 2003, pp. 612–618.
- [9] R. Rezaei-pour and A. Kazemi, "Review of novel control strategies for UPQC," Int. J. Elect. Power Eng., vol. 2, 2008, pp. 241–247.