

# **AUTOMATIC BUCK-BOOST CONVERTER FOR AUTOMOBILE USE**

**Debolina Dey<sup>1</sup>, Gunjan J. Tetar<sup>2</sup>**

Assistant professor, Dept. of EE, MEFGI College, Rajkot, Gujarat, India<sup>1</sup>

Assistant professor, Dept. of EE, MEFGI College, Rajkot, Gujarat, India<sup>2</sup>

**ABSTRACT:** As the development of the in car electronics and automatic parts the capacity of the current 14 volt voltage no longer meets the demand of the on board devices. An upgrade is imminent. In order to be backward compatible with the existing 14 volt system and to introduce extensive modifications, a dual 14v/42v system is developed as a compromising solution to the problems. Based on the new system this article proposes a bi-directional DC/DC converter. Extensive study on the stability, reliability and capability, indicates that under changing power directions. This new converter is able to do a closed loop control depending upon the current value and direction.

**KEYWORDS:** Bi- directional, Converter, Closed loop.

## **I.INTRODUCTION**

Bi- directional DC/DC converter has gained interest in both the industries as well as in academic field of power electronics, which can act as a platform for transaction of different DC voltage values and make management of power at the two level of power system. It has promising prospect in application of automation electronics, photo voltaic cell, solar energy generation and wind power generation.

The demand to improve the performance, fuel economy and passenger convenience and safety has grown drastically in recent times. The standard 14 Volt electrical power systems can no longer meet the demand of the modern day automobiles. A German forum has come up with a proposal to boost the present in car voltage level from 14 volt to 42 volt, which in turn increases the power capacity to 8 KW. In this article we are introducing the Bi- Directional DC/DC converter. It contains control circuit which is able to determine the operating mode based on the inductance current direction, it then stabilizes the closed loop without changing the present parameters of the system. The DC/DC converter which is used for automobiles has a strict requirement for cost, volume and efficiency. A BUCK/BOOST converter is used for the same purpose.

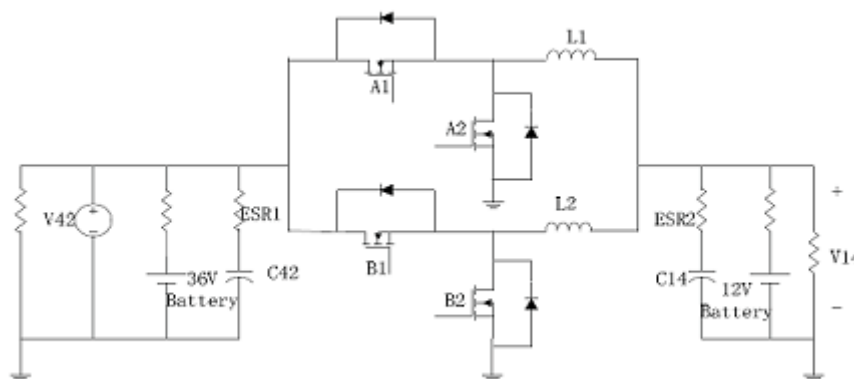

Fig 1: Simulated circuit of Bi-Directional Boost- Buck Converter.

# International Journal of Advanced Research in Electrical, Electronics and Instrumentation Engineering

(An ISO 3297: 2007 Certified Organization)

Vol. 3, Issue 1, January 2014

This circuit shows the bi-directional dc/dc converter, which operates on both the directions. During the boost phase first of all two switches  $A_2$  and  $B_2$  are closed so that both the inductors can get charged and the energy is stored in both of them, so the total energy stored in the inductors is  $V_{L1} + V_{L2}$ , when switch  $A_2$  and  $B_2$  are open, total energy transferred to the load is  $V_{L1} + V_{L2} + V_{in}$  (during the boost phase), so as a result the output voltage is boosted to a higher value than that of the input voltage, whereas on the other phase of the circuit operation i.e., during the buck phase the output voltage is chopped down from a higher value to lower output value. During this phase switches  $A_2$  and  $B_2$  are on/off state, at this condition the inductors are not getting charged further, instead they start discharging the energy stored in them via the load resistances.

## II. OPERATING PRINCIPLE OF THE BI-DIRECTIONAL DC/DC CONVERTER

Implementing a 14v/42v converter with a buck-boost topology using an active switch instead of a diode is more desirable. As bi-directional operation is possible without any additional requirement of components, efficiency is also very high than a typical buck-boost converter using a diode. The two active switches turn on and off alternatively through the main switches or the freewheeling diodes as per the mode of operation. The DC/DC converter is connected parallel with the batteries with 42 volt and 14 volt loads on either side of the circuit. The control method which is used is the current control method instead of a voltage control method, since the mode of operation is detected by the change in the inductor current, rather not by inductor voltage, current control method has a faster response than voltage control method. The further advantage is stability as current control loop is more stable than a voltage control loop.

The three modes of converter operation can be listed as follows, (i) when the inductor current is above zero, the converter works in the buck mode and the 42 volt energy bus provides energy to the 42 Volt loads as well as charge the batteries also. The second mode of operation involves (ii) when the inductor current is above zero; the converter operates in the boost mode. The 14 volt bus provides energy to the both sides of the load and charge the battery. Whereas the third modes of operation involves (iii) when the inductor current repeat working through the zero, the converter operates in the alternating mode.

The working of the converter depending on the various values of the inductor current can be shown by a graphical representation as shown below.

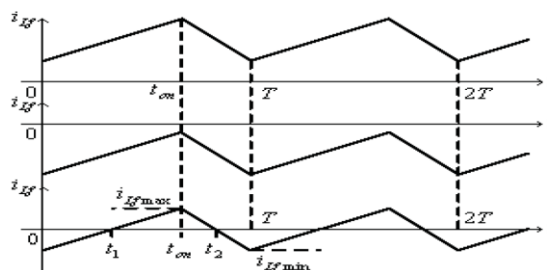

Fig 2: Modes of Converters depending on Inductor current values.

The working is determined by the loads and the voltage of the two , but it is un necessary to design two separate buck and boost converter, so the main aim of this article is to design a single converter implemented with both boost and buck action.

# International Journal of Advanced Research in Electrical, Electronics and Instrumentation Engineering

(An ISO 3297: 2007 Certified Organization)

Vol. 3, Issue 1, January 2014

## III. THE PROPOSED CONTROL METHOD

In this article a typical closed loop control of buck-boost operation is being designed. The closed loop operation is determined by using a general purpose PWM IC U3525. The whole control circuit consists of an inductor current measurement circuit, current regulator voltage regulator and PWM generation unit. All above mentioned devices worked under a stable condition. The sensing signal of the inductor current goes through the measurement circuit. If the output signal is positive then the converter operates in the buck mode and if the output signal is negative then the converter circuit operates in the boost mode. The enabled signal is determined by the inductor current which is a digital signal according to the average value of the inductor current. VA and CA are voltage regulator and current regulators respectively. The switches in the main power circuit are a MOSFET.

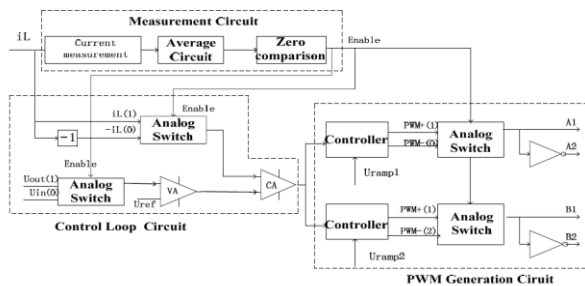

Fig: 3 Shows the closed control loop of Bi- Directional DC/ DC converter.

## IV. EXPERIMENTAL RESULTS

The proposed strategy was experimentally verified by simulation of a prototype model of BUCK- BOOST converter. The simulated output results are given as below.

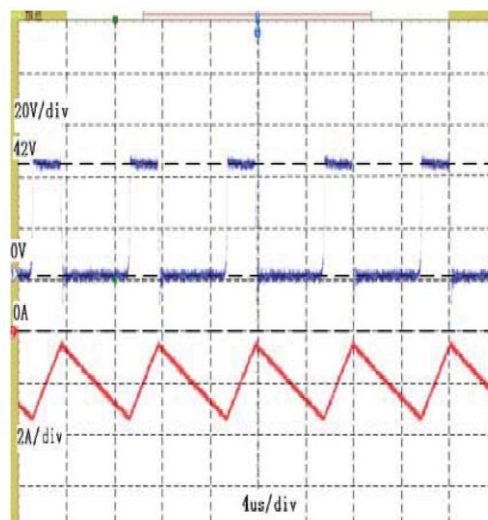

Fig 4: Simulated Output Inductor current for a Boost Converter.

The fig 4. Shows the simulated result of the inductor current for a boost converter, where the voltage level is being boosted from 14 volt to 42 volt as an output.

# International Journal of Advanced Research in Electrical, Electronics and Instrumentation Engineering

(An ISO 3297: 2007 Certified Organization)

Vol. 3, Issue 1, January 2014

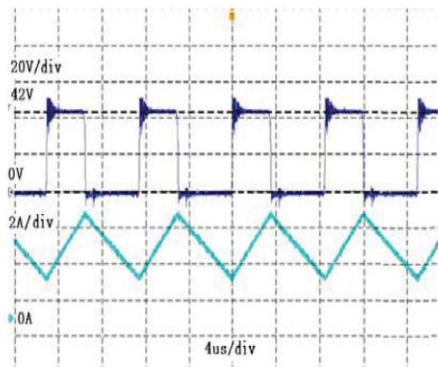

Fig. 5 Simulated Output Inductor current for a Buck Converter

The fig. 5 shows the simulated output of the inductor current for a buck converter, where the voltage level is being decremented to 14 volt from 42 volt using a buck converter. Both the input and output voltages are DC voltages.

## V.CONCLUSION

The Bi- Directional DC/DC converter has a promising prospect in the automation electronic area. This article proposes a double loop control system based on the different inductor current direction and in different work mode as the system itself can differentiate out between buck modes and boost mode. This proposed circuit can further be reinforced by extensive experimentation and future research.

## REFERENCES

- [1] Chang-Gyu Yoo, Woo-Cheol Lee, KynChan Lee, “Current Mode PWM Controller for a 42V/14V bidirectional DC/DC Converter” Power Electronics Specialists Conference, 2006.
- [2] Chin Chang, Knights, “M.A. Interleaving technique in distributed power conversion system Circuits and Systems: Fundamental Theory and Applications”, IEEE Transactions, Volume: 42 Issue: 5, May 1995 Page(s):245-251.
- [3] M. Gerber, J. Ferreira, I. W. Hofsjager, N. Seliger, “Interleaving Optimization in Synchronous Rectified DC/DC Converter” 35<sup>th</sup> Annual Power Electronics Specialists Conference 2004, Page: 4655-4661.
- [4] Oscar Garcia, Pablo Zumel, Angel de Castro and Jose A. Cobos, “Automotive DC-DC bidirectional converter made with many interleaved buck stages”, IEEE transaction on power electronics, Vol 21, No 3, MAY 2006
- [5] L.Jourdan, JL.Schanen, J.Roudet, M.Bensaied, K.Segueni, “Design Methodology for Non Insulated DC-DC Converter Application to 42V-14V Power net”, IEEE-2002.
- [6] K. Rajashekara, “Power conversion and control strategies for fuel cell vehicles,” in Proc. IEEE IECON’03 2003, vol. 3, pp: 2865–2870.
- [7] T. Kinjo, T. Senjyu, N. Urasaki, and H. Fujita, “Output levelling of renewable energy by electric double layer capacitor applied for energy storage system”, IEEE Transaction on Energy Convers, vol. 21, no.1.



ISSN (Print) : 2320 – 3765  
ISSN (Online): 2278 – 8875

# International Journal of Advanced Research in Electrical, Electronics and Instrumentation Engineering

*(An ISO 3297: 2007 Certified Organization)*

**Vol. 3, Issue 1, January 2014**

## BIOGRAPHY



**Debolina Dey:** Working as assistant professor in Electrical Engineering Department at Marwadi Education Foundation Group of Institutions, Rajkot, Gujarat (India). She completed B.Tech in Biomedical and Instrumentation Engineering and M.Tech in Electronics and control engineering from SRM University Chennai, Tamil Nadu (India). She has 18<sup>th</sup> month of teaching Experience and one year research experience.



**Gunjan J. Tetar:** Working as assistant professor in Electrical Engineering Department at Marwadi Education Foundation Group of Institutions, Rajkot, Gujarat (India). He completed B.E in Power Electronics Engineering and M.E in Power Electronics engineering from Lukhdhirji Engineering College Morbi, Gujarat(India). He has 18<sup>th</sup> month of teaching Experience and one year research experience.