



e-ISSN: 2278-8875
p-ISSN: 2320-3765



International Journal of Advanced Research

in Electrical, Electronics and Instrumentation Engineering

Volume 13, Issue 5, May 2024



ISSN INTERNATIONAL
STANDARD
SERIAL
NUMBER
INDIA

Impact Factor: 8.317



Attribute Based Privacy Preserving Task Assignment and Incentive Mechanism for Crowdsensing

R. Harish¹, G. Gopikrishnan², S. Abishek³, S. Saranraj⁴, S. Saravanan⁵

UG Students, Department of Electrical and Electronics Engineering, Muthayammal Engineering College,
Tamil Nadu, India^{1,2,3},

Associate Professor, Department of Electrical and Electronics Engineering, Muthayammal Engineering College,
Tamil Nadu, India⁴

Professor, Department of Electrical and Electronics Engineering, Muthayammal Engineering College,
Tamil Nadu, India⁵

ABSTRACT: This project proposes a secured ATM (Automated Teller Machine) system using a card scanning system along with LINK system for improved security. Usual ATM systems do not contain the LINK feature for money withdrawal. If an attacker manages to get hold of ATM card and the pin number, he may easily use it to withdraw money fraudulent. So our proposed system supports the ATM card scanning system along with an LINK system. This user may scan his card and login to the system. But after user is through with this authentication he may view details but is asked to enter LINK as soon as he clicks money withdrawal option. At this stage the system generates and sends an LINK to the registered mobile number to that particular user. The password is generated and sent to the user mobile phone. He now needs to enter the LINK in the system in order to withdraw money. Thus our system provides a totally secure way to perform ATM transactions with two level security structure.

KEYWORDS: Arduino UNO Microcontroller, 16x2 LCD, Keil c51 c Compilers, IC Voltage Regulators.

I.INTRODUCTION

An embedded system is some combination of computer hardware and software, either fixed in capability or programmable, that is designed for a specific function or for specific functions within a larger system. Industrial machines, agricultural and process industry devices, automobiles, medical equipment, cameras, household appliances, airplanes, vending machines and toys as well as mobile devices are all possible locations for an embedded system. Embedded systems are computing systems, but can range from having no user interface (UI) for example, on devices in which the embedded system is designed to perform a single task to complex graphical user interfaces (GUI), such as in mobile devices. User interfaces can include buttons, LEDs, touchscreen sensing and more. Some systems use remote user interfaces as well. Embedded systems can be microprocessor or microcontroller based. In either case, there is an integrated circuit (IC) at the heart of the product that is generally designed to carry out computation for real-time operations. Microprocessors are visually indistinguishable from microcontrollers, but whereas the microprocessor only implements a central processing unit (CPU) and thus requires the addition of other components such as memory chips, microcontrollers are designed as self-contained systems.

Embedded systems can be microprocessor or microcontroller based. In either case, there is an integrated circuit (IC) at the heart of the product that is generally designed to carry out computation for real-time operations. Microprocessors are visually indistinguishable from microcontrollers, but whereas the microprocessor only implements a central processing unit (CPU) and thus requires the addition of other components such as memory chips, microcontrollers are designed as self-contained systems. With the development of computer network technology and e-commerce, the self-service banking system has got extensive popularization with the characteristic offering high-quality 24 hours service for customer. Nowadays, using the ATM (Automatic Teller Machine) which provides customers with the convenient banknote trading is very common. However, the financial crime case rises repeatedly in recent years; a lot of criminals tamper with the ATM terminal and steal user's credit card and password by illegal means. Once user's bank card is lost and the password is stolen, the criminal will draw all cash in the shortest time, which will bring enormous financial losses to customer. How to carry on the valid identity to the customer becomes the focus in current financial circle. Traditional ATM systems authenticate generally by using the credit card and the password, the method has some defects. Using credit card and password cannot verify the client's identity exactly. Anyone who knows the PIN and have the ATM card can easily access the user account.



II.EXISTING SYSTEM

The existing ATM Simulation System was built for the original concept of regional private banks. Small banks in villages and towns will service the needs of the local community and will only require ledgers to record account details. This system is prone to human error and causes undue frustration to users. This system was augmented with the introduction of excel sheets and emails. Banks could now record all information in an excel sheet and then set an update schedule when they will mail all records to a central hub where these records will again be processed and consolidated to form a unified record of all account transactions. These systems did not enable easy access to money and were greatly prone to grievous errors..

III.PROPOSED SYSTEM

The proposed system aims to solve all this by constant updating of bank records. The Java based construction of the system will enable transactions at any bank or ATM to be registered within a matter of seconds. Security of these details is also a top priority in this system. This central hub will be accessed by an ATM for secure customer transactions. In our project we are going to place an extra button in ATM machines. When that button got pressed the control window will be telecasted to accountant cellular phone. Then the accountant can enter the pin and amount manually in his mobiles telecasted pop-up window. By this control system accountant can keep his pin number with him and he can vend the amount by his own control by the desired person. As assembly language programs are specific to a processor, assembly language didn’t offer portability across systems. To overcome this disadvantage, several high level languages, including C, came up. Embedded systems programming is different from developing applications on a desktop computers.

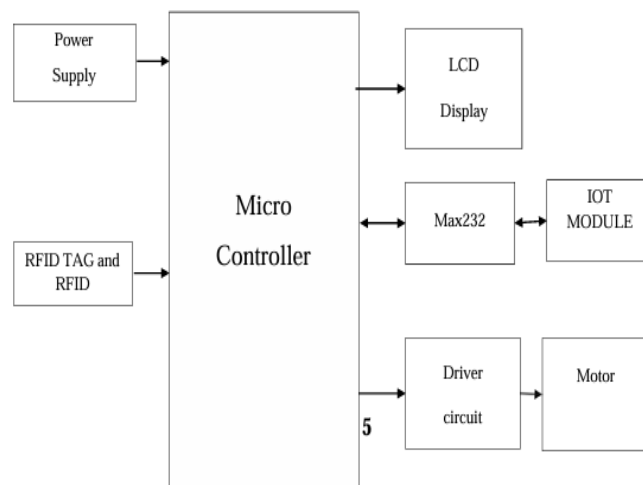

Figure.1. Block Diagram of Proposed System

ARDUINO UNO R3 MICROCONTROLLER

The Arduino Uno R3 is a microcontroller board based on the ATmega328. It has 14 digital input/output pins (of which 6 can be used as PWM outputs), 6 analog inputs, a 16 MHz crystal oscillator, a USB connection, a power jack, an ICSP header, and a reset button. It contains everything needed to support the microcontroller; simply connect it to a computer with a USB cable or power it with AC-to-DC adapter or battery to get started. The Uno differs from all preceding boards in that it does not use the FTDI USB-to-serial driver chip. Instead, it features the Atmega16U2(Atmega8U2 up to version R2) programmed as a USB-to-serial converter. Revision 2 of the Uno board (A000046) has a resistor pulling the 8U2 HWB line to ground, making it easier to put into DFU mode.

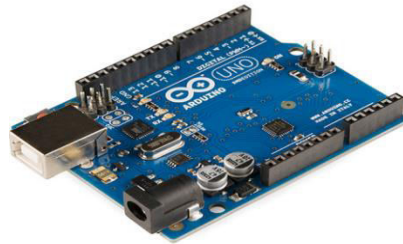

Figure.2.Microcontroller

16x2 LCD

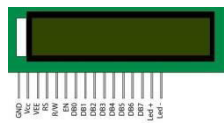

Figure.3.16x2LCD

A 16x2 LCD means it can display 16 characters per line and there are 2 such lines. In this LCD each character is displayed in 5x7 pixel matrix. This LCD has two registers, namely, Command and Data. The command register stores the command instructions given to the LCD. Voltage regulators comprise a class of widely used ICs. Regulator IC units contain the circuitry for reference source, comparator amplifier, control device, and overload protection all in a single IC. IC units provide regulation of either a fixed positive voltage, a fixed negative voltage, or an adjustably set voltage. The regulators can be selected for operation with load currents from hundreds of milli amperes to tens of amperes, corresponding to power ratings from milli watts to tens of watts.

IV.HARDWARE RESULTS

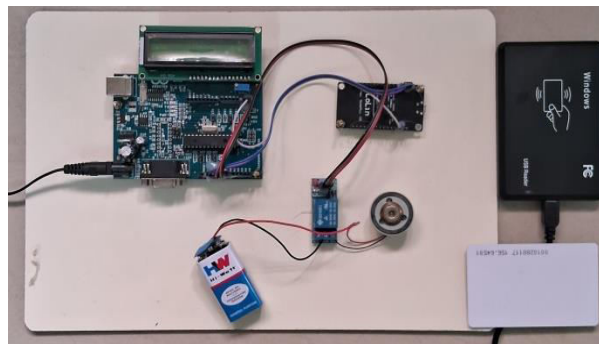

Figure.4. Hardware Results

This whole implementation ensures us a secured and authenticated transaction through RFID and GSM technique with lowest cost and minimum maintenance. Mankind will utilize new and secured type of money transactions. The only thing is that initial cost of RFID conversion of the entire system is the required one time investment. The value added service that this system provides increases the credibility of the financial institutions, the banks improves the convenience to its customer. Hence as the world progresses through the inevitable and an indomitable quest for knowledge, the aspect of security bound systems are bound to concede with the growing innovations and obviously more vulnerabilities. Hence our application might well solve the aspect of transaction security to a precise and great extent.

V.CONCLUSION

Overall the project represents a significant advancement in the field, offering a comprehensive solution to address key challenges and enhance the overall effectiveness of crowdsensing platforms. Through the integration of attribute-based



privacy-preserving techniques, dynamic task assignment algorithms, and personalized incentive mechanisms. Overall, the attribute-based privacy-preserving task assignment and incentive mechanism proposed for crowdsensing offer a holistic approach to address the complex challenges faced by existing systems. By combining state-of-the-art techniques with innovative algorithms and incentive structures, the proposed system lays the foundation for the development of a robust, secure, and participant-centric crowdsensing framework capable of unlocking new opportunities for collaborative data collection and analysis across various domains.

REFERENCES

1. G.Udaya Sree, M.Vinusha “ Real Time SMS-Based Hashing Scheme for Securing Financial Transactions on ATM Terminal”, IJSETR, ISSN 2319-8885 Vol.02, Issue.12, September-2013, Pages:1223-1227.
2. Khatmode Ranjit P, Kulkarni Ramchandra V, “ARM7 Based Smart ATM Access & Security System Using Fingerprint Recognition & GSM Technology”, ISSN 2250-2459, ISO 9001:2008 Certified Journal, Volume 4, Issue 2, February 2014. .
3. M.R.Dineshkumar, M.S.Geethanjali, “Protected Cash Withdrawal in ATM Using Mobile Phone”, International Journal Of Engineering And Computer Science ISSN:2319-7242 Volume 2 Issue 4 April, 2013 Page No. 1346-1350.
4. Zaid Imran, Rafay Nizaami, “Advance Secure Login”, International Journal For Science and Research Publications, Volume 1, Issue 1, December 2011.
5. M. Ajaykumar and N. Bharath Kumar, “Anti-Theft ATM Machine Using Vibration Detection Sensor”, IJARCSSC Volume 3, Issue 12, December 2013 ISSN: 2277 128X.
6. SURAJ B S and Dr. R GIRISHA, “ARM7 based Smart ATM Access System”, International Journal on Recent and Innovation Trends in Computing and Communication ISSN: 2321-8169 Volume: 3 Issue: 5.
7. K.annan K, “Microcontroller Based Secure Pin Entry Method For ATM”, International Journal of Scientific & Engineering Research, Volume 4, Issue 8, August-2013 ISSN 2229-5518.
8. Hyung-Woo Lee, “Security in Wireless Sensor Networks: Issues and Challenges”, ICACT, ISBN 89-5519-129-4, Feb. 20-22, 2006.
9. V.Dhinesh, T.Premkumar, S.Saravanan and G.Vijayakumar, “Online Grid Integrated Photovoltaic System with New Level Inverter System” International Research Journal of Engineering and Technology (IRJET), Vol.5, Issue 12, pp.1544-1547, 2018.
10. J.Vinoth, T.Muthukumar, M.Murugandam and S.Saravanan, “Efficiency Improvement of Partially Shaded PV System, International Journal of Innovative Research in Science, Engineering and Technology, Vol.4, Special issue 6, pp.1502-1510, 2015.
11. M.B.Malayandi, Dr.S.Saravanan, Dr. M.Muruganandam, “A Single Phase Bridgeless Boost Converter for Power Factor Correction on Three State Switching Cells”, International Journal of Innovative Research in Science, Engineering and Technology, Vol. 4, Special Issue 6, pp. 1560-1566, May 2015.
12. A.Sasipriya, T.Malathi, and S.Saravanan, “Analysis of Peak to Average Power Ratio Reduction Techniques in SFBC OFDM System” IOSR Journal of Electronics and Communication Engineering (IOSR-JECE), Vol. 7, No.5, 2013.
13. P.Ranjitha, V.Dhinesh, M.Muruganandam, S.Saravanan, “Implementation of Soft Switching with Cascaded Transformers to drive the PMDC Motor”, International Journal of Innovative Research in Science, Engineering and Technology, Vol. 4, Special Issue 6, pp. 1411-1418, May 2015.
14. C.Sowmiya, N.Mohanandhini, S.Saravanan and M.Ranjitha, “Inverter Power Control Based On DC-Link Voltage Regulation for IPMSM Drives using ANN” International Research Journal of Engineering and Technology (IRJET), Vol.5, Issue 11, pp.1442-1448, 2018.
15. N.Yuvaraj, B.Deepan, M.Muruganandam, S.Saravanan, “STATCOM Based of Adaptive Control Technique to Enhance Voltage Stability on Power Grid”, International Journal of Innovative Research in Science, Engineering and Technology, Vol. 4, Special Issue 6, pp. 1454-1461, May 2015.
16. P.Manikandan, S.Karthick, S.Saravanan and T.Divya, “Role of Solar Powered Automatic Traffic Light Controller for Energy Conservation” International Research Journal of Engineering and Technology (IRJET), Vol.5, Issue 12, pp.989-992, 2018.
17. R.Satheesh Kumar, D. Kanimozhi, S. Saravanan, “An Efficient Control Scheme for Wind Farm Using Back to Back Converter,” International Journal of Engineering Research & Technology (IJERT), Vol. 2, No.9, pp.3282-3289, 2013.
18. K.Prakashraj, G.Vijayakumar, S.Saravanan and S.Saranraj, “IoT Based Energy Monitoring and Management System for Smart Home Using Renewable Energy Resources,” International Research Journal of Engineering and Technology, Vol.7, Issue 2, pp.1790-1797, 2020.



19. J Mohammed siddi, A. Senthil kumar, S.Saravanan, M. Swathisriranjani, “Hybrid Renewable Energy Sources for Power Quality Improvement with Intelligent Controller,” International Research Journal of Engineering and Technology, Vol.7, Issue 2, pp.1782-1789, 2020.
20. S. Raveendar, P.M. Manikandan, S. Saravanan, V. Dhinesh, M. Swathisriranjani, “Flyback Converter Based BLDC Motor Drives for Power Device Applications,” International Research Journal of Engineering and Technology, Vol.7, Issue 2, pp.1632-1637, 2020.
21. K. Manikanth, P. Manikandan, V. Dhinesh, Dr. N. Mohananthini, Dr. S. Saravanan, “Optimal Scheduling of Solar Wind Bio-Mass Systems and Evaluating the Demand Response Impacts on Effective Load Carrying Capability,” International Research Journal of Engineering and Technology, Vol.7, Issue 2, pp.1632-1637, 2020.
22. T.R. Vignesh, M.Swathisriranjani, R.Sundar, S.Saravanan, T.Thenmozhi,” Controller for Charging Electric Vehicles Using Solar Energy”, Journal of Engineering Research and Application, vol.10, Issue.01,pp.49-53, 2020.
23. V.Dhinesh, Dr.G.Vijayakumar, Dr.S.Saravanan,” A Photovoltaic Modeling module with different Converters for Grid Operations”, International Journal of Innovative Research in Technology, vol.6, Issue 8, pp.89-95, 2020.
24. V. Dhinesh, R. Raja, S. Karthick, Dr. S. Saravanan,” A Dual Stage Flyback Converter using VC Method”, International Research Journal of Engineering and Technology, Vol.7, Issue 1, pp.1057-1062, 2020.
25. G. Poovarasan, S. Susikumar, S. Naveen, N. Mohananthini, S. Saravanan,” Study of Poultry Fodder Passing Through Trolley in Feeder Box,” International Journal of Engineering Technology Research & Management, vol.4, Issue.1, pp.76-83, 2020.
26. C. Sowmya, N. Mohananthini, S. Saravanan, and A. Senthil kumar,” Using artificial intelligence inverter power control which is based on DC link voltage regulation for IPMSM drives with electrolytic capacitor,” AIP Conference Proceedings 2207, 050001 (2020); <https://doi.org/10.1063/5.0000390>, Published Online: 28 February 2020.
27. M.Revathi, S.Saravanan, R.Raja, P.Manikandan,” A Multiport System for A Battery Storage System Based on Modified Converter with MANFIS Algorithm,” International Journal of Engineering Technology Research & Management, vol.4, issue 2, pp.217-222, 2020.
28. D Boopathi, S Saravanan, Kaliannan Jagatheesan, B Anand, “Performance estimation of frequency regulation for a micro-grid power system using PSO-PID controller”, International Journal of Applied Evolutionary Computation (IJAEC), Vol.12, Issue.4, pp.36-49, 2021.
29. V Deepika, S Saravanan, N Mohananthini, G Dineshkumar, S Saranraj, M Swathisriranjan, “Design and Implementation of Battery Management System for Electric Vehicle Charging Station”, Annals of the Romanian Society for Cell Biology, Vol.25, Issue.6, 17769-17774, 2021.
30. A Senthilkumar, S Saravanan, N Mohananthini, M Pushparaj, “Investigation on Mitigation of Power Quality Problems in Utility and Customer side Using Unified Power Quality Conditioner”, Journal of Electrical Systems, Vol.18, Issue.4, pp.434-445, 2022.
31. V Kumarakrishnan, G Vijayakumar, D Boopathi, K Jagatheesan, S Saravanan, B Anand,” Frequency regulation of interconnected power generating system using ant colony optimization technique tuned PID controller”, Control and Measurement Applications for Smart Grid: Select Proceedings of SGESC 2021, pp..129-141.
32. C Nagarajan, B Tharani, S Saravanan, R Prakash,” Performance estimation and control analysis of AC-DC/DC-DC hybrid multi-port intelligent controllers based power flow optimizing using STEM strategy and RPFC technique”, International Journal of Robotics and Control Systems”, Vol.2, Issue.1, pp.124-139, 2022.
33. G Vijayakumar, M Sujith, S Saravanan, Dipesh B Pardeshi, MA Inayathullaa,” An optimized MPPT method for PV system with fast convergence under rapidly changing of irradiation”, 2022 International Virtual Conference on Power Engineering Computing and Control: Developments in Electric Vehicles and Energy Sector for Sustainable Future (PECCON), pp.1-4.
34. C Nagarajan, K Umadevi, S Saravanan, M Muruganandam, “Performance Analysis of PSO DFFP Based DC-DC Converter with Non Isolated CI using PV Panel”, International Journal of Robotics and Control Systems’ Vol.2, Issue.2, pp.408-423, 2022.
35. VM Geetha, S Saravanan, M Swathisriranjani, CS Sathesh, S Saranraj, “Partial Power Processing Based Bidirectional Converter for Electric Vehicle Fast Charging Stations”, Journal of Physics: Conference Series, Vol.2325, Issue.1, pp.012028, 2022.
36. M Santhosh Kumar, G Dineshkumar, S Saravanan, M Swathisriranjani, M Selvakumari, “Converter Design and Control of Grid Connected Hybrid Renewable Energy System Using Neuro Fuzzy Logic Model”, 2022 Second International Conference on Computer Science, Engineering and Applications (ICCSEA), pp.1-6, 2022.
37. C Gnanavel, A Johny Renoald, S Saravanan, K Vanchinathan, P Sathishkhanna, “An Experimental Investigation of Fuzzy-Based Voltage-Lift Multilevel Inverter Using Solar Photovoltaic Application”, Smart Grids and Green Energy Systems, pp.59-74, 2022.



38. C Nagarajan, K Umadevi, S Saravanan, M Muruganandam, “Performance investigation of ANFIS and PSO DFFP based boost converter with NICI using solar panel”, International Journal of Engineering, Science and Technology, Vol.14, Issue.2, pp.11-21,2022.
39. K Priyanka, N Mohananthini, S Saravanan, S Saranraj, R Manikandan, “Renewable operated electrical vehicle battery charging based on fuzzy logic control system”, AIP Conference Proceedings, Vol.2452, Issue.1, pp.030007, 2022.
40. V Kumarakrishnan, G Vijayakumar, D Boopathi, K Jagatheesan, S Saravanan, B Anand, “Optimized PSO technique based PID controller for load frequency control of single area power system”, Solid State Technology, Vol.63. Issue.5, pp.7979-7990, 2020.
41. G. Poovarasan, S. Susikumar, S. Naveen, N. Mohananthini, S. Saravanan, “Implementation of IoT Based Poultry Feeder Box”, International Journal of Innovative Research In Technology, Vol.6, Issue.2, pp.33-38, 2020.
42. N.Gokulnath, B.Jasim Khan, S.Kumaravel, Dr.A.Senthil Kumar and Dr.S.Saravanan, “Soldier Health and Position Tracking System”, International Journal of Innovative Research In Technology (IJIRT)), Vol-6 Issues 12, pp.39-45, 2020.
43. P.Navaneetha, R.Ramiya Devi, S.Vennila, P.Manikandan and Dr.S.Saravanan , “ IOT Based Crop Protection System against Birds and Wild Animal Attacks”, International Journal of Innovative Research In Technology (IJIRT)), Vol-6 Issues 11, pp.133-143, 2020.
44. V. Dhinesh, D. Prasad, G. Jeevitha, V. Silambarasan, Dr. S. Saravanan, “ A Zero Voltage Switching Pulse Width Modulated Multilevel Buck Converter”, International Research Journal of Engineering and Technology (IRJET), Vol 7 Issue 3, pp.1764,2020.
45. K. Punitha, M. Rajkumar, S. Karthick and Dr. S. Saravanan, “ Impact of Solar And Wind Integration on Frequency Control System”, International Research Journal of Engineering and Technology (IRJET), Vol 7 Issue 3, pp.1357-1362,2020.
46. A.Arulkumar, S.Balaji, M.Balakrishnan, G.Dineshkumar and S.Saravanan, “Design And Implementation of Low Cost Automatic Wall Painting Machine” International Journal of Engineering Technology Research & Management (IJETRM), Vol-4 Issues 03, pp.170-176, 2020.
47. V.Periyasamy, S.Surya, K. Vasanth, Dr.G.Vijayakumar and Dr.S.Saravanan, “Design And Implementation of Iot Based Modern Weaving Loom Monitoring System” International Journal of Engineering Technology Research & Management (IJETRM), Vol-4 Issues 04, pp.11-18, 2020.
48. M.Yogheshwaran, D.Praveenkumar,S.Pravin,P.M.Manikandan and Dr.S.Saravanan, “IoT Based Intelligent Traffic Control System” International Journal of Engineering Technology Research & Management (IJETRM), Vol-4 Issues 04, pp.59-63, 2020.
49. R.Pradhap, R.Radhakrishnan, P.Vijayakumar, R.Raja and Dr.S.Saravanan, “Solar Powered Hybrid Charging Station For Electrical Vehicle” International Journal of Engineering Technology Research & Management (IJETRM), Vol-4 Issues 04, pp.19-27, 2020
50. S.Shenbagavalli, T.Priyadharshini, S.Sowntharya, P.Manikandan and Dr.S.Saravanan, “Design and Implementation of Smart Traffic Controlling System” International Journal of Engineering Technology Research & Management (IJETRM), Vol-4 Issues 04, pp.28-36, 2020.
51. M.Pavithra, S.Pavithra, R.Rama Priya, M.Vaishnavee, M.Ranjitha and S.Saravanan, “Fingerprint Based Medical Information System Using IoT” International Journal of Engineering Technology Research & Management (IJETRM), Vol-4 Issues 04, pp.45-51, 2020.
52. A.Ananthan, A.M.Dhanesh, J.Gowtham, R.Dhinesh, G.Jeevitha and Dr.S.Saravanan, “IoT Based Clean Water Supply” International Journal of Engineering Technology Research & Management (IJETRM), Vol-4 Issues 03, pp.154-162, 2020.
53. R.Anbarsan, A.Arsathparvez, K.S.Arunachalam, M.Swathisriranjani and Dr.S.Saravanan, “Automatic Class Room Light Controlling Using Arduino” International Journal of Engineering Technology Research & Management (IJETRM), Vol-4 Issues 03, pp.192-201, 2020.
54. S.Karthikeyan, A.Krishnaraj, P.Magendran, T.Divya and Dr.S.Saravanan , “The Dairy Data Acquisition System” International Journal of Engineering Technology Research & Management (IJETRM), Vol-4 Issues 03, pp.163-169, 2020.
55. M.Amaran, S.Mannar Mannan, M.Madhu, Dr.R.Sagayaraj and Dr. S.Saravanan, “Design And Implementation of Low Cost Solar Based Meat Cutting Machine” International Journal of Engineering Technology Research & Management (IJETRM), Vol-4 Issues 03, pp.202-208, 2020.
56. N.Harish, R.Jayakumar, P.Kalaiyaran, G.Vijayakumar and S. Saravanan, “IoT Based Smart Home Energy Meter” International Journal of Engineering Technology Research & Management (IJETRM), Vol-4 Issues 03, pp.177-183, 2020.



57. K.Subashchandrabose, G.Moulieshwaran, M.Raghul, V.Dhinesh and S.Saravanan, “Design of Portable Sanitary Napkin Vending Machine”, International Journal of Engineering Technology Research & Management (IJETRM), Vol-4 Issues 03, pp.52-58, 2020.
58. R.Gopi, K.Gowdhaman, M.Ashok, S.Divith, S.Saravanan and G.Dineshkumar, “An Online Method of Estimating State of Health of A Li-Ion Battery”, International Journal of New Innovations in Engineering and Technology, Vol.22, Issue.3, pp.31-36, 2023.
59. S.Azhaganandham, P.Elangovan, M.S.Kayalkan, M.Dineshkumar and S.Saravanan, “Automatic Direct Torque Control System For 3 Phase Induction Motor”, International Journal of New Innovations in Engineering and Technology, Vol.22, Issue.3, pp.1-3, 2023.
60. K. Ranjith Kumar, A.Naveen, R.Ragupathi, S. Savitha and S. Saravanan, “Automatic Industrial-Based Air Pollution Avoidance System Using Iot”, International Journal of New Innovations in Engineering and Technology, Vol.22, Issue.3, pp.100-105, 2023.
61. G.T.Nandhini, V.Megasri, T.Jeevitha, S.Sandhiya and S. Saravanan, “Automatic Pick And Drop Helping Robot”, International Journal of New Innovations in Engineering and Technology, Vol.22, Issue.3, pp.72-76, 2023.
62. K.Deepika, S.Divya, A.Hema, R.Meena, V.Deepika and S.Saravanan, “Automatic Solar Panel Cleaning System”, International Journal of New Innovations in Engineering and Technology, Vol.22, Issue.3, pp.62-66, 2023.
63. A.Balaji, K.Harikiruthik, A.Mohamed Hassan, S.Saravanan and S.Saranraj, “Design and Implementation of A Single Stage Multi-Pulse Flexible Topology Thyristor Rectifier for Battery Charging in Electric Vehicles”, International Journal of New Innovations in Engineering and Technology, Vol.22, Issue.3, pp.37-42, 2023.
64. D.Hemalatha, S.Indhumathi, V.Myvizhi and S.Saravanan, “Design and Implementation of Intelligent Controller for Domestic Applications”, International Journal of New Innovations in Engineering and Technology, Vol.22, Issue.3, pp.4-7, 2023.
65. N.Priyadharshini, S.Saraswathi, T.Swetha, K.Sivaranjani, K.Umadevi and S.Saravanan, “Fuel Monitoring System using IoT”, International Journal of New Innovations in Engineering and Technology, Vol.22, Issue.3, pp.126-130, 2023.
66. S. Divyasri, E. Indhu, M. P. Keerthana, M. Selvakumari and S. Saravanan, “Gas Cylinder Monitoring System using IoT”, International Journal of New Innovations in Engineering and Technology, Vol.22, Issue.3, pp.67-71, 2023.
67. J.Arul, R.Balaji, S.Jeyamoorthy, M.Manipathra, R.Sundar and S.Saravanan, “IoT based Air Conditioner Control using ESP32”, International Journal of New Innovations in Engineering and Technology, Vol.22, Issue.3, pp.48-52, 2023.
68. Vundel Munireddy, J.Prahathesvaran, C.R.Thirunavukarasu, M.Santhosh Kumar and S.Saravanan, “IoT Based Charge Controller for Direct Fast Charging of Electric Vehicles Using Solar Panel”, International Journal of New Innovations in Engineering and Technology, Vol.22, Issue.3, pp.77-81, 2023.
69. D.Monish Kumaar, K.Akash, S.Aswinkumar, S.Saravanan and R. Sagayaraj, “IoT based Industry Surveillance and Air Pollution Monitoring using Drones”, International Journal of New Innovations in Engineering and Technology, Vol.22, Issue.3, pp.14-18, 2023.
70. T.Silambarasan, R.Surya, J.Pravinkumar, R.Sundar and S Saravanan, “IoT based Monitoring System For Sewage Sweeper”, International Journal of New Innovations in Engineering and Technology, Vol.22, Issue.3, pp.88-93, 2023.
71. R.Aravinthan, Alwin.Augustin, P.Divagaran, S.Saravanan and P.Manikandan, “IoT Based Power Consumption and Monitoring System”, International Journal of New Innovations in Engineering and Technology, Vol.22, Issue.3, pp.43-47, 2023.
72. S.Partheeban, S.Sundaravel, S.Umapathi, R.Sagayaraj and S.Saravanan, “IoT based Safety Helmet for Mining Workers”, International Journal of New Innovations in Engineering and Technology, Vol.22, Issue.3, pp.116-120, 2023.
73. D.K.Vignesh, K.Sabarishwaran, S.Yuvaraj, P.Manikandan and S Saravanan, “IoT based Smart Dustbin”, International Journal of New Innovations in Engineering and Technology, Vol.22, Issue.3, pp.82-87, 2023.
74. P Muthukrishnan, P Poovarasan, S Vasanth, R Raja and S Saravanan, “Smart Borewell Child Rescue System”, International Journal of New Innovations in Engineering and Technology, Vol.22, Issue.3, pp.121-125, 2023.
75. S. Gokul, B. Gokulnath, P. Manikandan, S.Saravanan and N. Mohananthini, “Smart Crop Protection From Animals And Birds Using Arduino”, International Journal of New Innovations in Engineering and Technology, Vol.22, Issue.3, pp.19-25, 2023.
76. M.Abinesan, S.Jawahar, S.A.Gopi, A.Gokulraj and S.Saravanan, “Smart EV Charging Hub Integrated with Renewable Energy for Highway Utility”, International Journal of New Innovations in Engineering and Technology, Vol.22, Issue.3, pp.58-61, 2023.



77. K.Eswaramoorthi, R.Manikandan, R.Balamurugan, C.Ramkumar and S.Saravanan, “Smart Parking System using IoT”, International Journal of New Innovations in Engineering and Technology, Vol.22, Issue.3, pp.53-57, 2023.
78. S.Nirmalraj, C.Pranavan, M.Prem and S.Saravanan, “Smart Trolley With IoT Based Billing System”, International Journal of New Innovations in Engineering and Technology, Vol.22, Issue.3, pp.111-115, 2023.
79. S. NithyaSri, S.S.Sabitha, M.Thilagavathi, S.Umameshwari, C.Nithya and S.Saravanan, “Smart Wireless Notice Board using IoT”, International Journal of New Innovations in Engineering and Technology, Vol.22, Issue.3, pp.106-110, 2023.
80. V.Gunasekaran, M.Gowtham, S. Anbubalaji, S.Saravanan and R.Prakash, “Solar based Electric Wheel Chair”, International Journal of New Innovations in Engineering and Technology, Vol.22, Issue.3, pp.8-13, 2023.
81. S.Naveenkumar, S.Prakash, A.P.Shrikirishnaa, C.Ramkumar and S.Saravanan, “Two to Three Phase 5HP Digital Panel”, International Journal of New Innovations in Engineering and Technology, Vol.22, Issue.3, pp.94-99, 2023.
82. Harivignesh K, Jaisankar.A, Chandru.J, Saravanan.S and Raja.R, “Voice Controlled Automatic Writer”, International Journal of New Innovations in Engineering and Technology, Vol.22, Issue.3, pp.26-30, 2023.
83. N.Sakthiselvam, S.Srinivasan, S.Raajkumar, M.Selvakumari, S.Saravanan, “An Integrated Fault Isolation and Prognosis Method for Electric Drive Systems of Battery Electric Vehicles”, International Journal of New Innovations in Engineering and Technology, Vol.22, Issue.3, pp.166-171, 2023.
84. P Thava Prakash, P.Venketesan, D.Vignesh, S.Prakash, S.Saravanan, “Design of Low Cost E-Bicycle using Brushless DC Motor with Speed Regulator”, International Journal of New Innovations in Engineering and Technology, Vol.22, Issue.3, pp.148-153, 2023.
85. D.Tamilarasan, V.S.Vairamuthu, Y.Vasanth, K.Umadevi, S.Saravanan, “GSM based Agricultural Motor Control”, International Journal of New Innovations in Engineering and Technology, Vol.22, Issue.3, pp.172-177, 2023.
86. P. Vimal, S.Veerasingamani, R.Srihari, C.S.Satheesh, S.Saravanan, “IoT Based Optimal Power Management System For Smart Grid”, International Journal of New Innovations in Engineering and Technology, Vol.22, Issue.3, pp.160-165, 2023.
87. S.Abimanyu, P.Jagadheeswaran, S.Jaganath, K.Sanjay, R.Sivapraneesh, K.Velmurugan, N.Mohananthini, C.S.Satheesh, S.Saravanan, “Portable Solar Tree”, International Journal of New Innovations in Engineering and Technology, Vol.22, Issue.3, pp.154-159, 2023.
88. J.Sriboopathi, G.Sridhar, R.Sharunesh, S.Tamilarasan, S.Saranraj and S.Saravanan, “A Dual Stage Power Electronic Converter for Electric Vehicle Charger”, International Journal of New Innovations in Engineering and Technology, Vol.22, Issue.3, pp.197-202, 2023.
89. M.Karthikeyan, S.Bilalahamad, V.A.Chandru, V.Deepika and S.Saravanan, “Design and Development of IoT based Motor Starter”, International Journal of New Innovations in Engineering and Technology, Vol.22, Issue.3, pp.178-183, 2023.
90. S.Yokesh, M.Manoj Kumar, M.Sankar, G.Dineshkumar and S.Saravanan, “Estimation of Maximum Power in Lithium Ion Batteries using IoT”, International Journal of New Innovations in Engineering and Technology, Vol.22, Issue.3, pp.191-196, 2023.
91. P.Preedeepa, S.Sivaranjani, M.Nandhini, M.Swathisriranjani and S.Saravanan, “Optimization of Power Quality Issues in EV Charging Station”, International Journal of New Innovations in Engineering and Technology, Vol.22, Issue.3, pp.203-209, 2023.
92. R. GokulRaj, N. Kannan, S. Karthick, M.Swathisriranjani and S.Saravanan, “Power Quality Enhancement in Smart Grids for Electric Vehicles Charging Station”, International Journal of New Innovations in Engineering and Technology, Vol.22, Issue.3, pp.184-190, 2023.

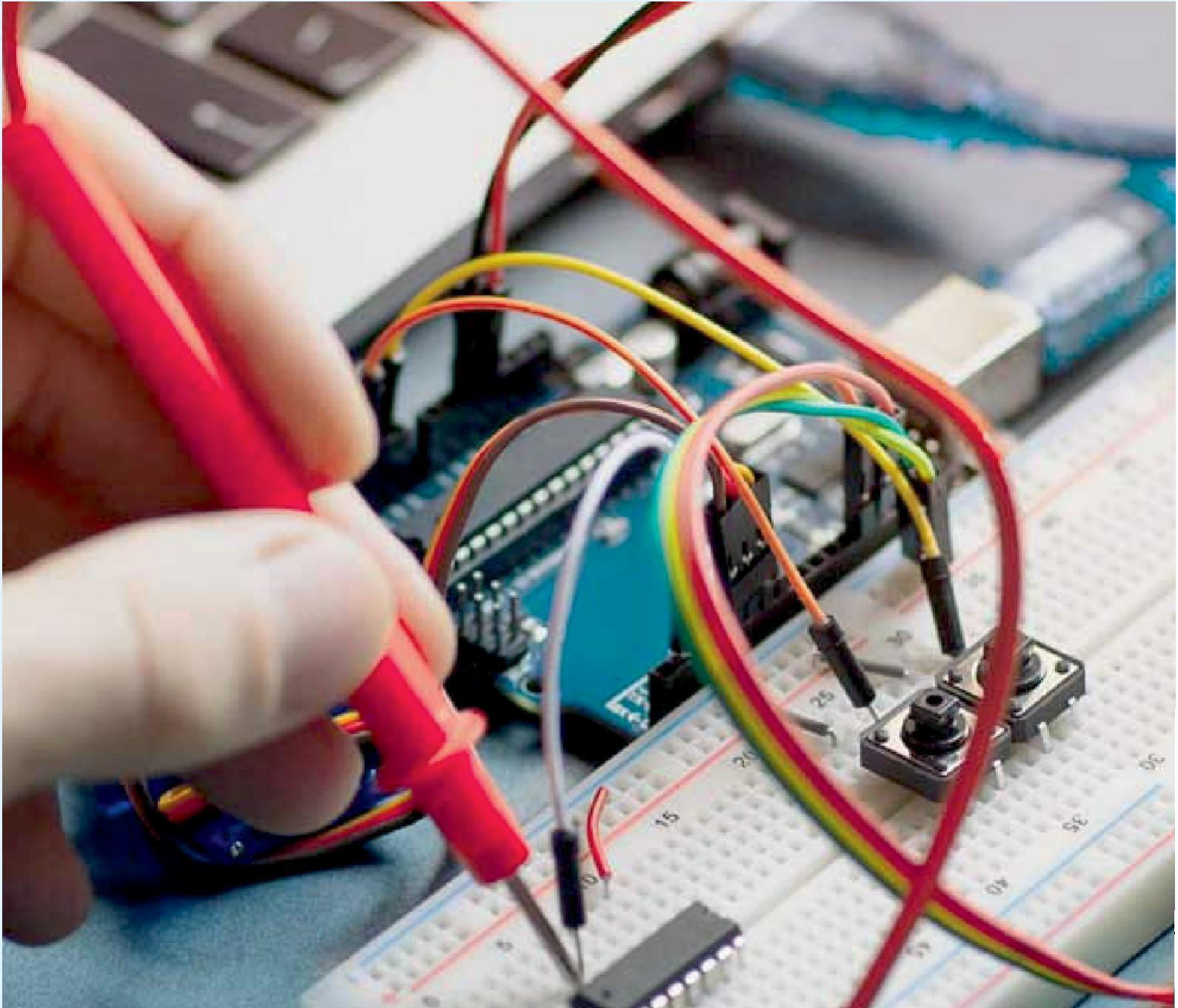

INNO  SPACE
SJIF Scientific Journal Impact Factor

 **doi**[®]
cross **ref**

 **INTERNATIONAL
STANDARD
SERIAL
NUMBER
INDIA**



International Journal of Advanced Research

in Electrical, Electronics and Instrumentation Engineering



www.ijareeie.com

Scan to save the contact details