



e-ISSN: 2278-8875  
p-ISSN: 2320-3765

# International Journal of Advanced Research

in Electrical, Electronics and Instrumentation Engineering

Volume 11, Issue 7, July 2022

**ISSN** INTERNATIONAL  
STANDARD  
SERIAL  
NUMBER  
INDIA

**Impact Factor: 8.18**

☎ 9940 572 462

☎ 6381 907 438

✉ [ijareeie@gmail.com](mailto:ijareeie@gmail.com)

@ [www.ijareeie.com](http://www.ijareeie.com)



# Novel Hybrid Maximum Power Tracking Technique for Partially Shaded PV Arrays

Sumit Gavhale<sup>1</sup> , Vaishali Malekar<sup>2</sup>

Students, Department of Electrical Engineering, Gaikwad Patil College of Engineering and Technology, Nagpur, India

Assistant Professor, Department of Electrical Engineering, Gaikwad Patil College of Engineering & Technology,  
Nagpur, India

**ABSTRACT:** Photovoltaic panels are the most important green energy source because of their inexhaustible moreover its clean. It is important to connect the PV panels to the maximum power point tracking (MPPT) controller to optimize its output power. The PV panels output power efficiency is related to the rapidly variation of the incident irradiance moreover the partial shading pattern. The variation of the incident irradiance and the partial shading pattern makes the tracking of the global maximum peak (GMP) through the local ones too difficult, which extremely decrease the efficiency of the PV panels. The problem is the GMP value varies as the sun irradiance varies so; the detection of the GMP needs an efficient and fast algorithm which cannot be done by the traditional MPPT. In order to solve the problem, proposed system a hybrid new algorithm can combine a traditional MPPT algorithm, such as perturb and observe, or incremental conductance, with the ANN (artificial neural network) This new algorithm can combine a traditional MPPT algorithm, The proposed hybrid MPPT algorithm is based on the ANN and used to predict the global MPP region by estimating its voltage boundaries. Consequently, the conventional MPPT algorithm searches for the MPP in the predicted region. The proposed technique is modeled and simulated using MATLAB/Simulink

**KEYWORDS:** Photovoltaic (PV), GMP,MPPT,ANN

## I. INTRODUCTION

Fossil fuels are non-renewable, limited in supply and environment polluting. Fossil fuels are the cause of global warming and climate change. The interest for alternative energy sources are increased to reduce our dependence on the primary energy supplies like fossil fuels as they are costly and deficient. Production of energy from alternative energy sources like solar, wind and moving water is required to fulfill the future energy demands of the society and to improve the energy security. The solar energy is most preferable as it provides clean green energy. The solar panels produce solar energy for free and have less maintenance cost. The solar electricity can be used for household appliances or sold renewable energy back to the National Grid. The Photovoltaic (PV) system converts solar energy into electricity. The number of series and parallel PV modules are connected together to form PV array. The current-voltage and power-voltage characteristics of PV system are highly non-linear. The peak point of the power voltage characteristic is called as maximum power point (MPP). The PV should operate at MPP to maximize the utilization of the PV system. A controller is required to track the MPP and the technique is known as Maximum power point tracking (MPPT). The MPP controller has to be connected in between the PV array and boost converter. When some part of the PV array is not fully illuminated the situation is known as partially shaded condition. The solar illumination in shaded condition is obstructed by trees, houses, buildings etc. The characteristics curve has only one peak for normal irradiance but contains multiple peaks in case of shading condition which makes the situation complicated. From the multiple peaks one is global peak and others are local peak. Different types of MPPT techniques have been proposed till date. Some commonly used MPPT techniques are Perturb and observe (P&O) method [3], Hill climbing method (HC) [4], and Incremental conductance method (INC) [5]. Perturbation in PV voltage and current is used in P&O method periodically to calculate PV output power at any instant which will be compared with the previously calculated power. If there is increase in PV power due to the perturbation then the direction of the perturbation is maintained till the MPP has reached. HC method is similar as the P&O method except the perturbation here is taken in the duty cycle. But the above methods are erroneous in partially shaded condition as steady state oscillations around The proposed hybrid MPPT algorithm is based on the ANN and used to predict the global MPP region by estimating its voltage boundaries. Consequently, the conventional MPPT algorithm searches for the MPP in the predicted region. The proposed technique is modeled and simulated using MATLAB/Simulink. The results will show the effectiveness of the proposed hybrid MPPT technique to track the global MPP accurately with a rapid response.; this



increases the output power level of the PV array under various shading patterns.

## II. PROBLEM FORMULATION

### Existing System

Existing system with conventional algorithms is the most versatile device. There are various types of conventional algorithms that can be used to track the MPP, such as P&O and IC. However, these algorithms may fail to track the MPP under PSCs, and they may become trapped at a local Perturbation in PV voltage and current is used in P&O method periodically to calculate PV output power at any instant which will be compared with the previously calculated power. If there is increase in PV power due to the perturbation then the direction of the perturbation is maintained till the MPP has reached.. But the above methods are erroneous in partially shaded condition as steady state oscillations around MPP are present. In Fig.1 a block diagram of the PV system is shown where the MPPT controller generates the reference voltage which is given to the control unit to generate duty cycle for the boost converter [1-2].

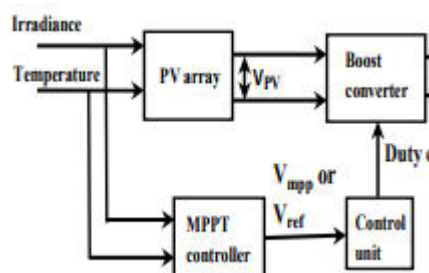

Fig. 1. Block diagram of PV system with boost converter

### Proposed System

Proposed system introduces a new concept As mentioned above, a power electronics converter is essential to connect PV arrays to the grid or load, as well as to execute the MPPT algorithm. There are different types of the DC/DC converters that can be utilized to carry out MPPT. In this paper, a boost converter is used. To explain the proposed technique, consider a string comprises four series PV arrays, each array is connected in parallel with a bypass diode, as shown in Fig. 1. The schematic diagram for the proposed system is shown in Fig. 2

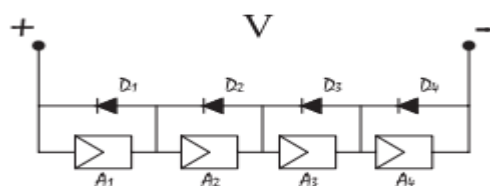

Fig 2-Four photovoltaic Arrays in Parallel with Bypass Diode

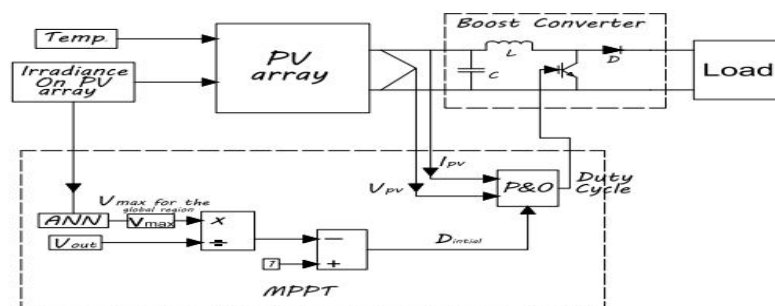

Fig 3: Proposed block diagram



**PV ARRAY UNDER PARTIAL SHADING**

Normally, a PV array comprises a large number of modules connected with each other in both series and parallel combinations. If there are several cells shaded within a module in a PV array, the array is said to be under PSC. Because the current of each PV cell inside a module depends on the solar irradiance, partial shading decreases the current for PV cells under shading, while the other unshaded cells produce high currents. Because the current flow through all the modules connected in series must be equal, this leads the cells under shading to operate in the reverse bias region and carry on the same current as the non-shaded modules as shown in Fig. 3. The cells under shading condition in the PV module absorb energy because of the reverse voltage across them. Consequently, the output power from the array is reduced. This energy is converted to heat, which may result in thermal breakdown of the shaded cells, causing a hotspot. Such thermal breakdown may cause cell breakdown, thereby generating an open circuit in the shaded PV string. This hotspot phenomenon can be eliminated using bypass diodes. The function of bypass diodes is to prevent the appearance of negative voltage.

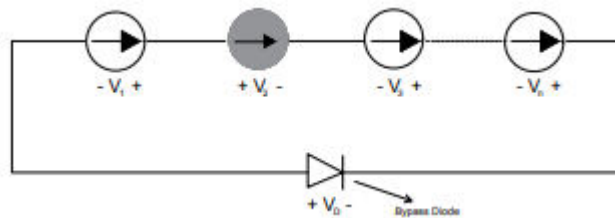

Fig-4 Bypass diode in parallel with photovoltaic cells; one cell is shaded.

The cells in the partial shaded module do not have the same current in this situation, which leads to multiple peaks in the power-voltage characteristic curve. Therefore, conventional MPPT methods will fail to track the global maximum power point (MPP) because of the local peaks. AI techniques or hybrid techniques where conventional MPPT is assisted by AI methods need to be used

**III. SIMULATION AND RESULT**

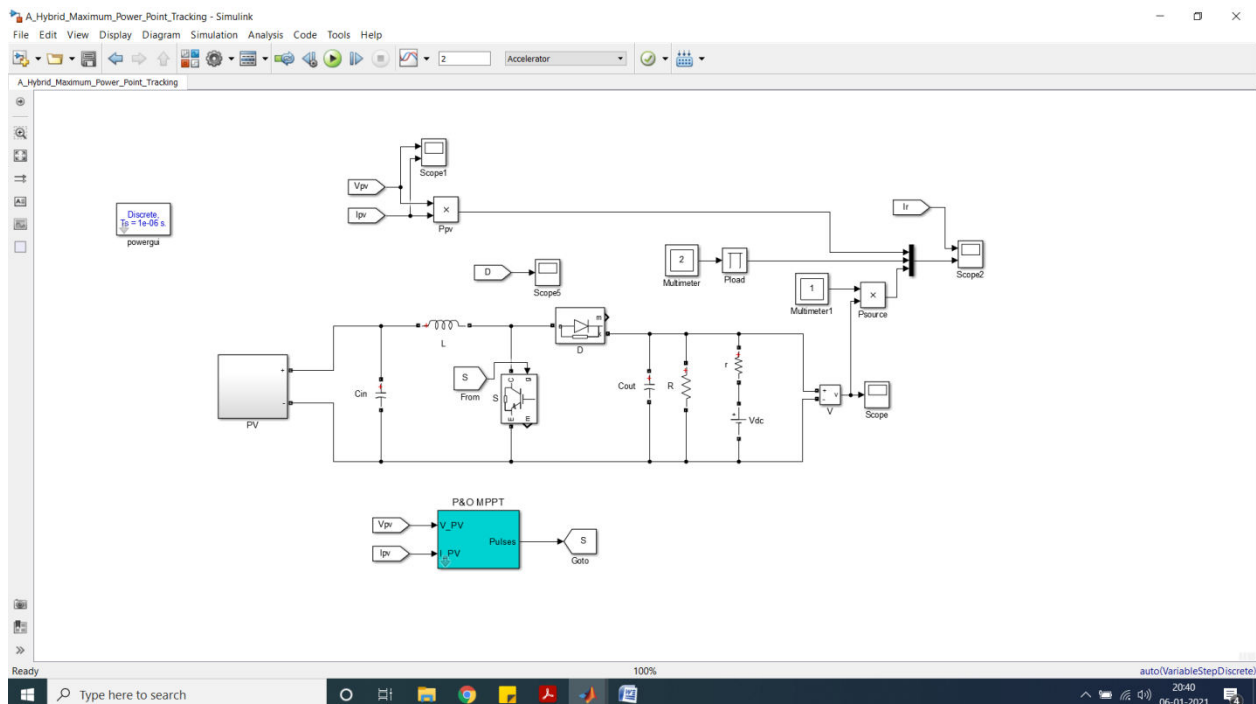

Fig. : 5 Proposed test system with four PVA module and P&O MPPT



The above is the proposed test system with PVA module connected to DC source through DC-DC booster converter controlled by modified ANN Vmax reference P&O MPPT method.

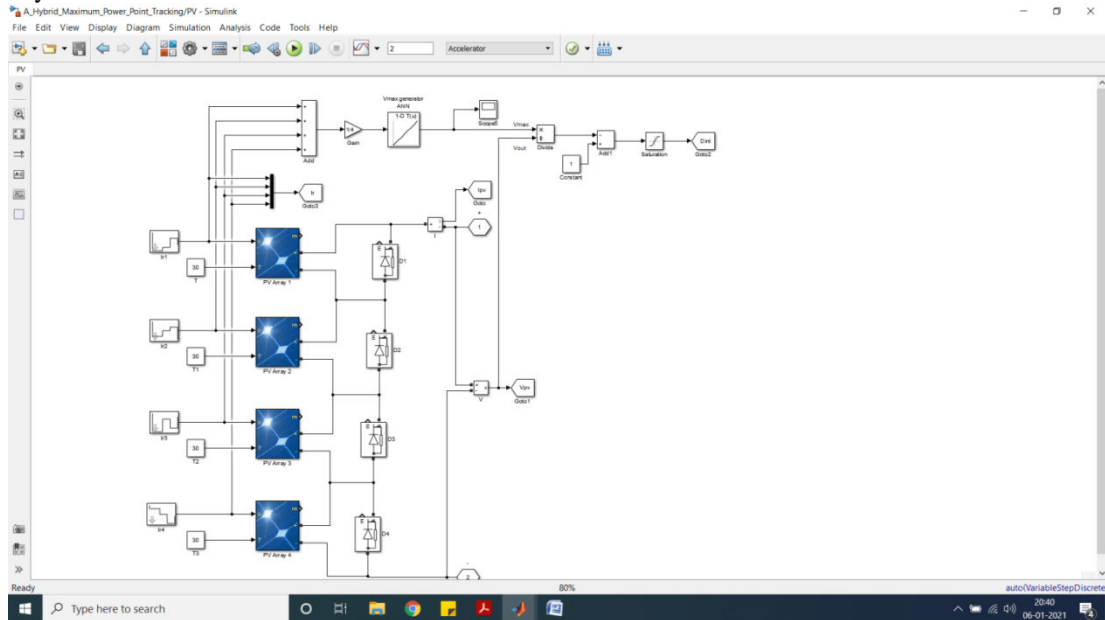

Fig. :6 Four PVA module internal modeling

The above is the internal modeling of four parallel connected PVA module with power sharing to the load as per the solar irradiation. Parameter Vmax is calculated as per the ANN training tool and given as initial duty ratio to the MPPT controller. The below is the conventional P&O MPPT method modeling for generation of change in duty ratio value.

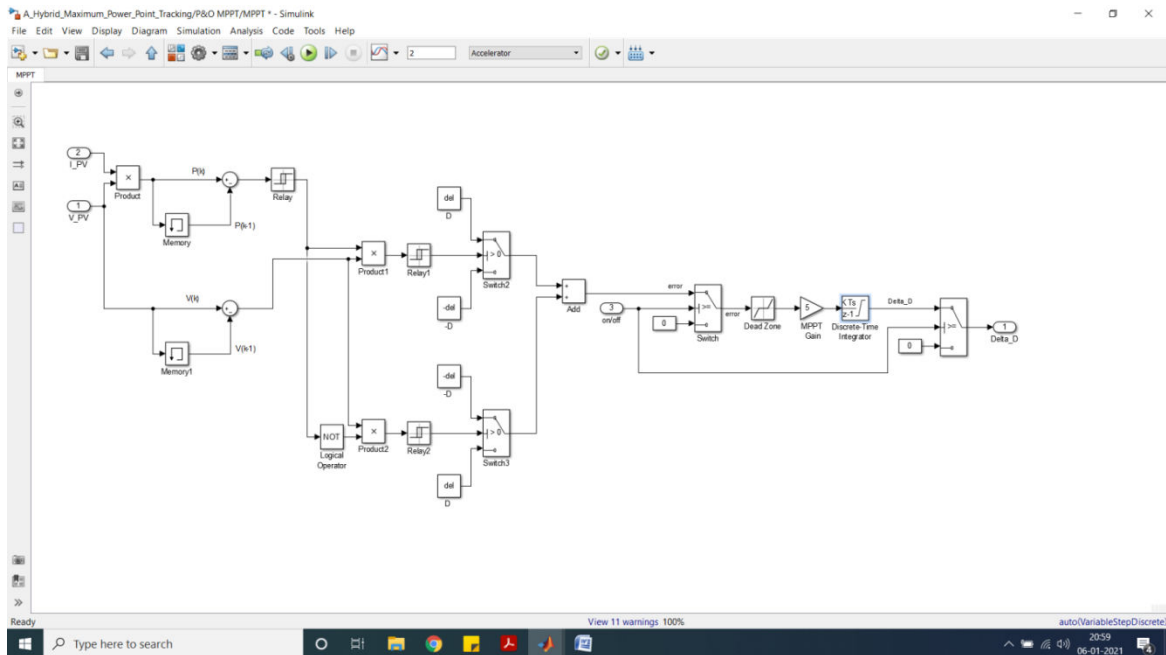

Fig. 7: P&O MPPT method modelling

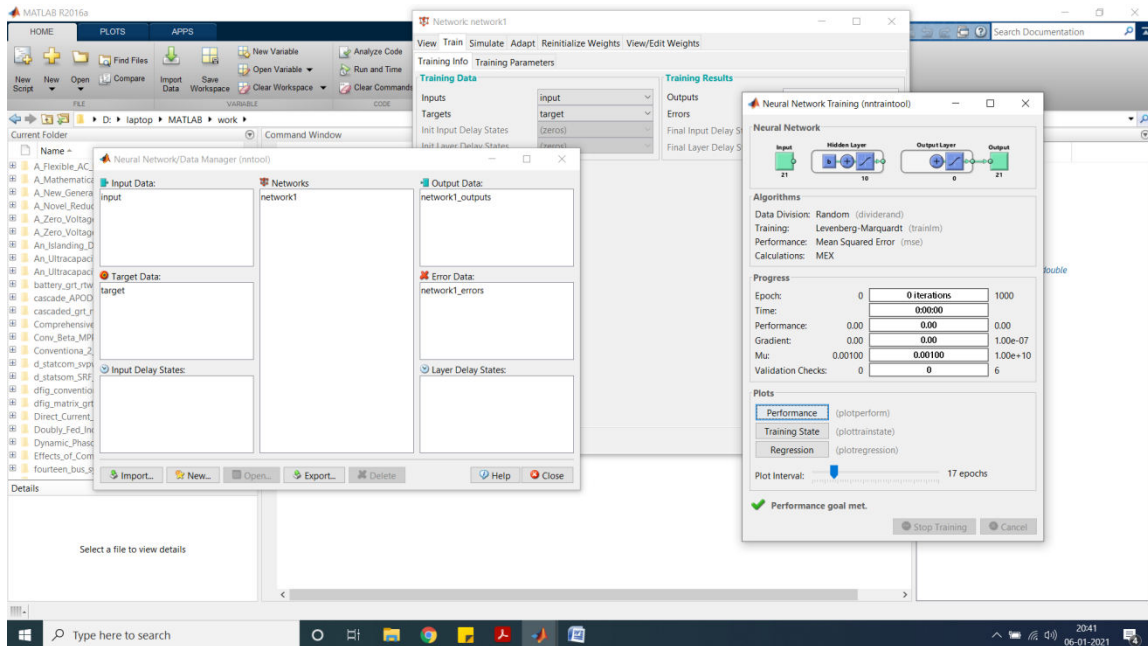
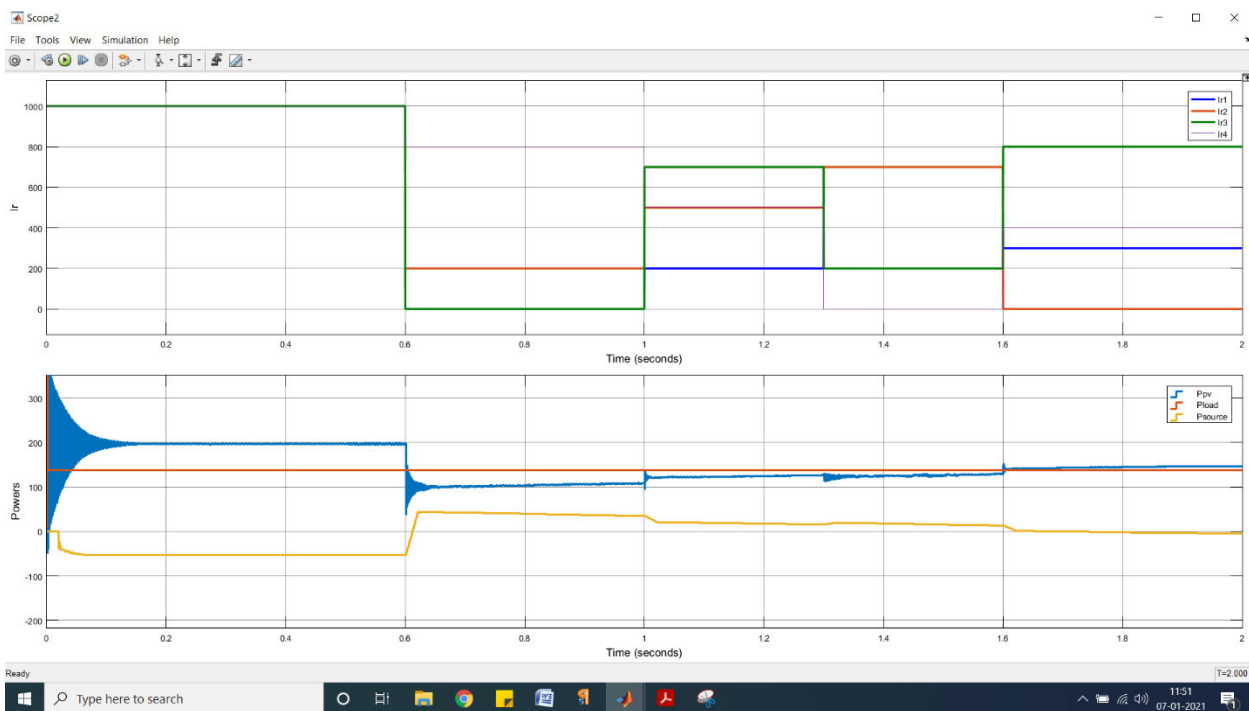

Fig. : 8 Neural network tool training for Vmax estimation

The above schematic represents neural network training for Vmax parameter as per the average solar irradiation on the PVA panels. The trained data is fed to characteristics table for generation of Vmax value. The below are the graphs recorded with simulation time of 2secs run by different solar irradiation conditions of PVA panels as per shading effect.



:Fig-9 Four PVA solar irradiations compared to powers of the test system

The above graph is the comparison of solar irradiations of four panels at different levels as per the shading conditions considered for the simulation. The second axis in the above graph is powers comparison of total PVA module, load and source. As can be seen the excess power from the PVA is injected into source and during deficit power from PVA power from DC source is utilized by the load. The negative power indicates injection of power to DC source and positive power



indicates delivery of power from DC source. The below graph is the change in duty ratio as per the change in solar irradiation in MPPT controller.

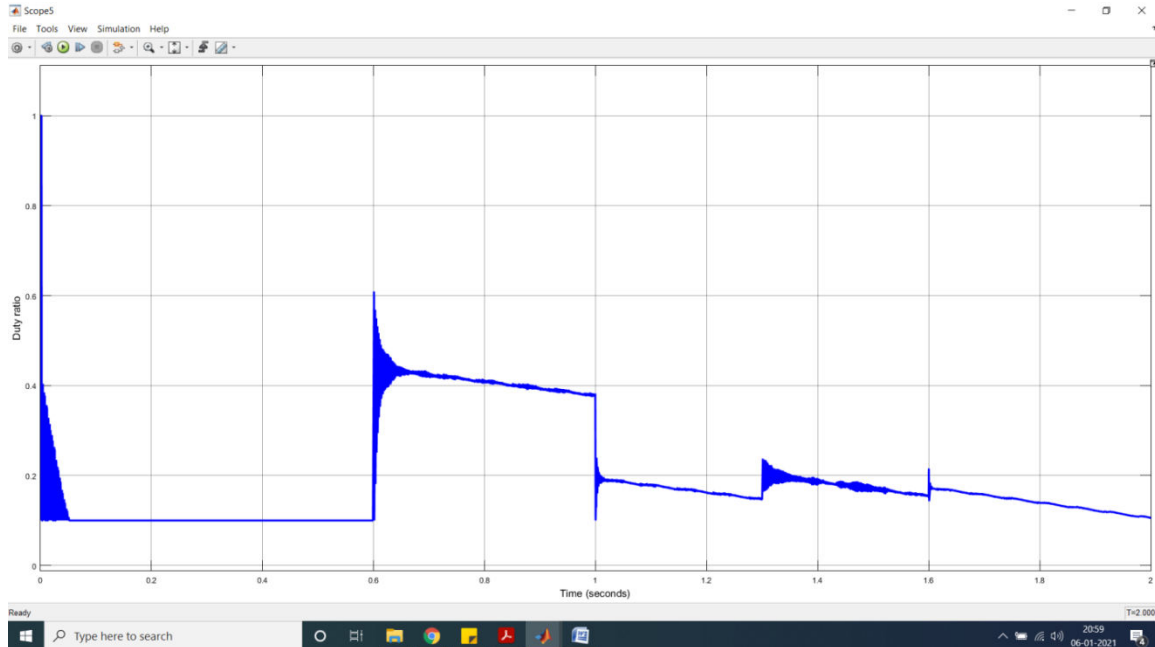

Fig.10 : Duty ratio of the boost switch

The total PVA module voltage and current can be seen below for the given change in solar irradiation parameters.

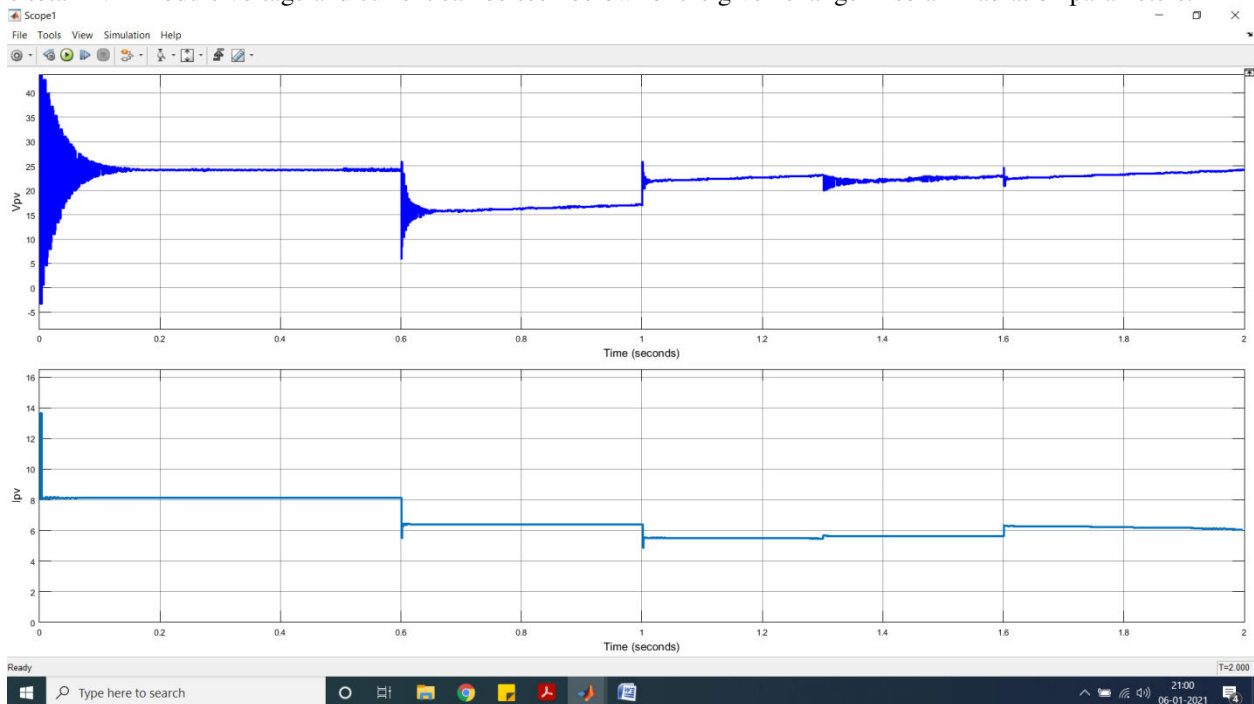

Fig11. : PVA module voltage and current output

### V. CONCLUSION

There are various types of conventional algorithms that can be used to track the MPP, such as P&O and IC. However, these algorithms may fail to track the MPP under PSCs, and they may become trapped at a local peak. This paper presents



an efficient hybrid algorithm for PV systems working under PSCs. A simplified ANN was proposed to obtain the region for the global MPP of the PV characteristics by estimating its boundary voltages, which varied with changes in the shading pattern on the PV array. After finding this region, a conventional method—namely P&O—was used to locate the MPP in the estimated region by adjusting the duty cycle of the boost converter. The results demonstrated the adequacy of the suggested hybrid MPPT technique in tracking the global MPP of the PV array with different partial SPs and under both steady-state and dynamic conditions.

## REFERENCES

- [1] L.L. Jiang, D.R. Nayanisiri, D.L. Maskell, and D.M. Vilathgamuwa, “A hybrid maximum power point tracking for partially shaded photovoltaic systems in the tropics,” *Renew. Energy*, vol. 76, pp. 53–65, Apr. 2015.
- [2] L.M. Elobaid, A.K. Abdelsalam, and E.E. Zakzouk, “Artificial neural network based maximum power point tracking technique for PV systems,” in *Proc. 38th Annu. Conf. IEEE Ind. Electron. Soc. (IECON)*, Oct. 2012, pp. 937–942.
- [3] F. Chekired, C. Larbes, and A. Mellit, “Comparative study between two intelligent MPPT controllers implemented on FPGA: Application for photovoltaic systems,” *Int. J. Sustain. Energy*, vol. 33, no. 3, pp. 483–499,
- [4] H.M. El-Helw, M. Al-Hasheem, and M.I. Marei, “Control strategies for the DAB based PV interfaces system,” *PLoS ONE*, vol. 11, no. 8, p. e0161856, Aug. 2016.
- [5] N. Patcharaprakiti, S. Premrudeepreechacharn, and Y. Sriuthaisiriwong, “Maximum power point tracking using adaptive fuzzy logic control for grid-connected photovoltaic system,” *Renew. Energy*, vol. 30, no. 11, pp. 1771–1788, Sep. 2005.
- [6] M.S. Ngan and C.W. Tan, “Multiple peak tracking algorithm using particle swarm optimization incorporated with artificial neural network,” *Int. J. Elect., Comput., Energetic, Electron. Commun. Eng.*, vol. 5, pp. 1320–1326, Oct. 2011.
- [7] A. Bidram, A. Davoudi, and R.S. Balog, “Control and circuit techniques to mitigate partial shading effects in photovoltaic arrays,” *IEEE J. Photovolt.*, vol. 2, no. 4, pp. 532–546, Oct. 2012.
- [8] R. Subha and S. Himavathi, “Neural network based maximum power point tracking scheme for PV systems operating under partially shaded conditions,” in *Proc. Int. Conf. Adv. Green Energy (ICAGE)*, Dec. 2014, pp. 39–43.
- [9] M.S. Ngan and C.W. Tan, “A study of maximum power point tracking algorithms for stand-alone photovoltaic systems,” in *Proc. IEEE Appl. Power Electron. Colloq. (IAPEC)*, Apr. 2011, pp. 22–27.



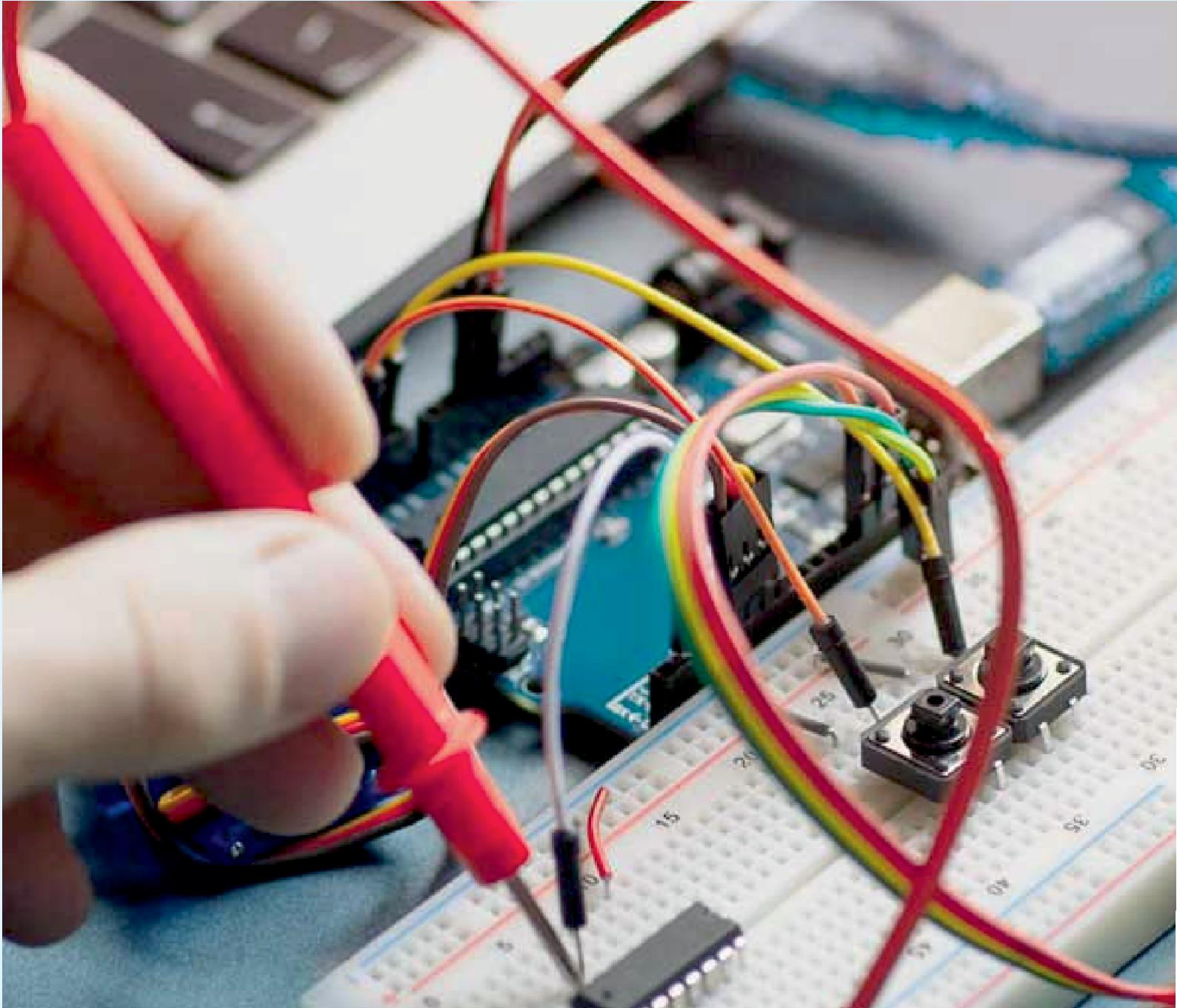

INNO  SPACE  
SJIF Scientific Journal Impact Factor

Impact Factor: 8.18



**ISSN** INTERNATIONAL  
STANDARD  
SERIAL  
NUMBER  
INDIA



# International Journal of Advanced Research

in Electrical, Electronics and Instrumentation Engineering

 9940 572 462  6381 907 438  [ijareeie@gmail.com](mailto:ijareeie@gmail.com)



[www.ijareeie.com](http://www.ijareeie.com)

Scan to save the contact details