



e-ISSN: 2278-8875

p-ISSN: 2320-3765

International Journal of Advanced Research

in Electrical, Electronics and Instrumentation Engineering

Volume 11, Issue 2, February 2022

ISSN INTERNATIONAL
STANDARD
SERIAL
NUMBER
INDIA

Impact Factor: 7.282

☎ 9940 572 462

☑ 6381 907 438

✉ ijareeie@gmail.com

@ www.ijareeie.com



Reduction of Mutual Coupling in Dual Patch Antenna by Defected Ground Structure

Vivian Lazarus¹, Sumit KR Sharma²

Student, Department of Electrical Engineering, IIT Bombay, Mumbai, India¹

Student, Department of Computer Science Engineering, DIAT(DU), Pune, India²

ABSTRACT: Defected ground structures are deliberate irregularities in the ground plane to intentionally modify antenna characteristics for emulating an aspect which is intended to modify certain parameter in order to improve antenna performance. In a dual patch antenna, it is desirable to reduce mutual coupling between radiating elements which in turn would ensure greater power transfer to radiation in desired direction as intended. Same has been achieved in this paper by employing I-shaped Defected ground structure in ground plane. This gave advantage of avoiding complex fabrication design of dual patch antenna without interference in other antenna parameters including bandwidth and frequency of operation while achieving 5.5 dB of suppression in mutual coupling.

KEYWORDS: defected ground structures, dual patch antenna, mutual coupling.

Abbreviations: DGS, defected ground structure; MIMO, multiple input multiple output; MSA, microstrip antenna.

I. INTRODUCTION

MIMO antennas have found its implementation in almost all wireless communication devices owing to its diversity [1]. Active elements in MIMO antenna are spaced in a closed packing which invariably results in mutual coupling. The same results in reduced transmission efficiency. Thus, it is necessary to devise means for reducing mutual coupling in a multi antenna system.

Literature survey was carried out to study existing techniques to study existing techniques for reducing Mutual Coupling. However, their design and fabrication procedures are complex for practical implementation [2-5]. Also, the reported design employs higher dielectric constant material as substrate. However, patch antennas over higher dielectric substrates results in reduced bandwidth and also has poor efficiency owing to surface wave losses [4].

In MSA, rectangular radiating patches are introduced over dielectric substrate and a metallic ground at the bottom. Patches are excited by a feed through bottom layers of substrate and ground. On excitation the effective length is increased due to fringing field effect. Same is represented in Fig-1.

To achieve higher fringing fields for higher radiation levels, often lower ϵ_r material substrate is employed. However, the same tends to increase cross polar radiation and mutual coupling which is an undesirable phenomenon. In this paper, an I-shaped DGS is introduced in the ground plane with relatively low ϵ_r (2.5) while achieving reduction in mutual coupling of a dual patch antenna by using DGS.

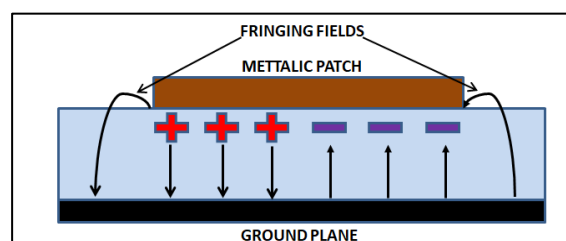

Fig-1. Schematic of Micro strip Antenna showing fringing fields.



II. GEOMETRY OF PROPOSED GROUND PLANE STRUCTURE

A dual patch rectangular MSA has been selected as active element and has been excited by 50 Ω matched coaxial feed line. To measure mutual coupling both the patches are placed with radiating edges facing each other. Frequency of operation is 5.3GHz with inter element spacing of 43mm. Size of ground plane is 90mm x 68mm and thickness of substrate is 2mm. i. e, of substrate material chosen is 2.5. The patch area corresponding to frequency of operation is 16mm x 21mm and the feed point is 3.95mm from the center of geometry. The proposed structure of dual patch antenna is shown in Fig. 2. DGS is I-shaped with length of 18.44mm and width of 4.6mm. Wings on all 4 sides are of length 4mm and width 0.75mm. The proposed DGS structure is shown in Fig. 3.

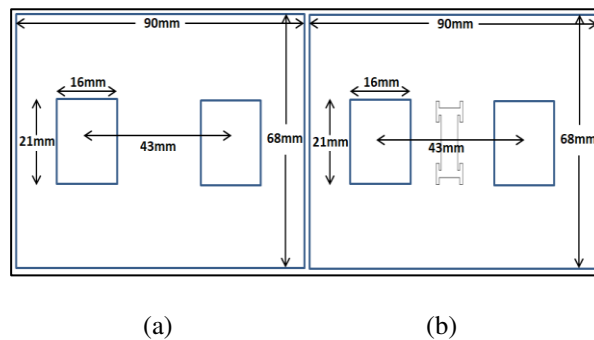

Fig. 2. (a) Dual patch antenna without I-shaped DGS. (b) Dual patch antenna with I-shaped DGS.

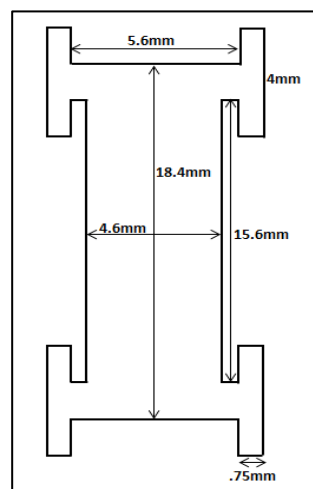

Fig. 3. Optimized dimension of I-shaped DGS for Fig-2 (b).

III. SIMULATION RESULTS

To investigate and optimize the operation of proposed structure, the proposed antenna is simulated by commercial software package IE3D. The operating frequency can be seen around 5.3GHz for dual patch antenna without DGS however, a slight right shift is observed with introduction of DGS which is insignificant. Also, the bandwidth of operation can be seen as 300-320 MHz for both with and without DGS. Therefore, introduction of DGS did not interfere with both operating frequency and -10 dB resonating frequency as shown in Fig. 4. In Fig. 5 at 5.25GHz, S_{21} is -24.1dB without DGS and it is reduced to -29.6dB after introduction of DGS. Thus, mutual coupling is improved by 5.5dB by introduction of DGS. Also, the improvement in mutual coupling is realized over whole operating bandwidth making the design further more practical for implementation.



IV. CONCLUSION

A simple I-shaped DGS has been designed for reducing mutual coupling between radiating elements of a dual patch antenna. The introduction of proposed DGS between the ground plane and metallic patches creates a bandgap in the frequency of operation. Mutual coupling is reduced by overall suppression of surface wave energy transfer. Also, both the frequency of operation and bandwidth of antenna are insensitive to the introduction of DGS. I-shaped DGS has been analyzed by the finite elements method and

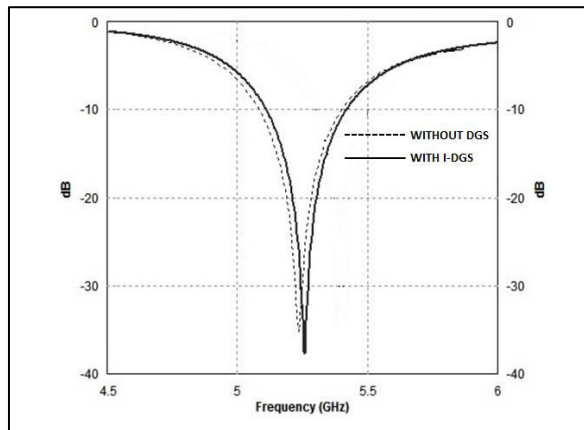

Fig. 4. Return Loss S_{22} , without and with I-shaped DGS.

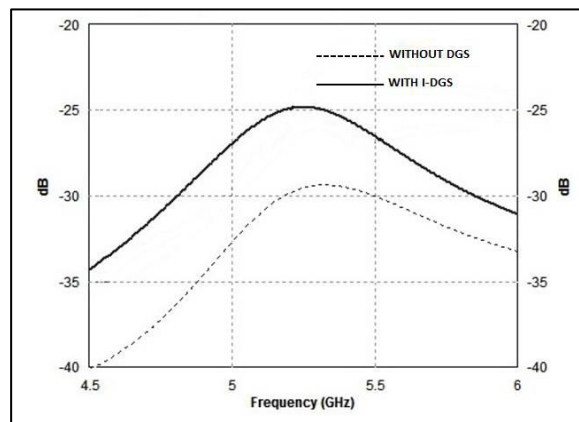

Fig. 5. Mutual Coupling S_{21} without and with I-shaped DGS.

is found effective in reduction of mutual coupling in a dual patch antenna by 5.5dB over whole bandwidth.

V. FUTURE SCOPE

The proposed design is simple and easy to implement during fabrication, thus may be useful in MIMO antenna technology for reducing mutual coupling between radiating elements.

Conflict of Interest: It is hereby declared by the authors that there are no conflicts of interest.

REFERENCES

[1]. Murch, R.D., and Letaief, K.B.: ‘Antenna systems for broadband wireless access’, IEEE Commun. Mag., 2002, 40, (4), pp.7-83
 [2]. D.B. Hru, S. Xiao, B. z. Wang, L, Jiang, J.Wang, W.Hong, “Elimination of scan-blindness with compact defected ground structures in mirostrip phased array”, IRT Microwave, Antenna and Propagation, Vol.3,Ins.2,pp. 269-275,2009.



- [3]. M.Salehi, A. Motevasselian, A Tavakoli and T. Heidari, “Mutual Coupling reduction of microstrip antennas using defected ground structure”, IEEE Singapore International Conference on communication Systems, ICCS, 2006.
- [4]. F.G.Zhu, J.D.Xu and Q. Xu, “Reduction of mutual coupling between closely-packed antenna elements using defected ground structure”, Electron, Lett., Vol.45,Iss.12, pp. 601-602, 2009.
- [5]. L.H.Weng, Y.C. Guo, X.W.Shi, and X.Q.hen, “An overview on defected ground structure”, Progress in Electromagnetics Research Letters, Vol.7,pp.173-189,2008.

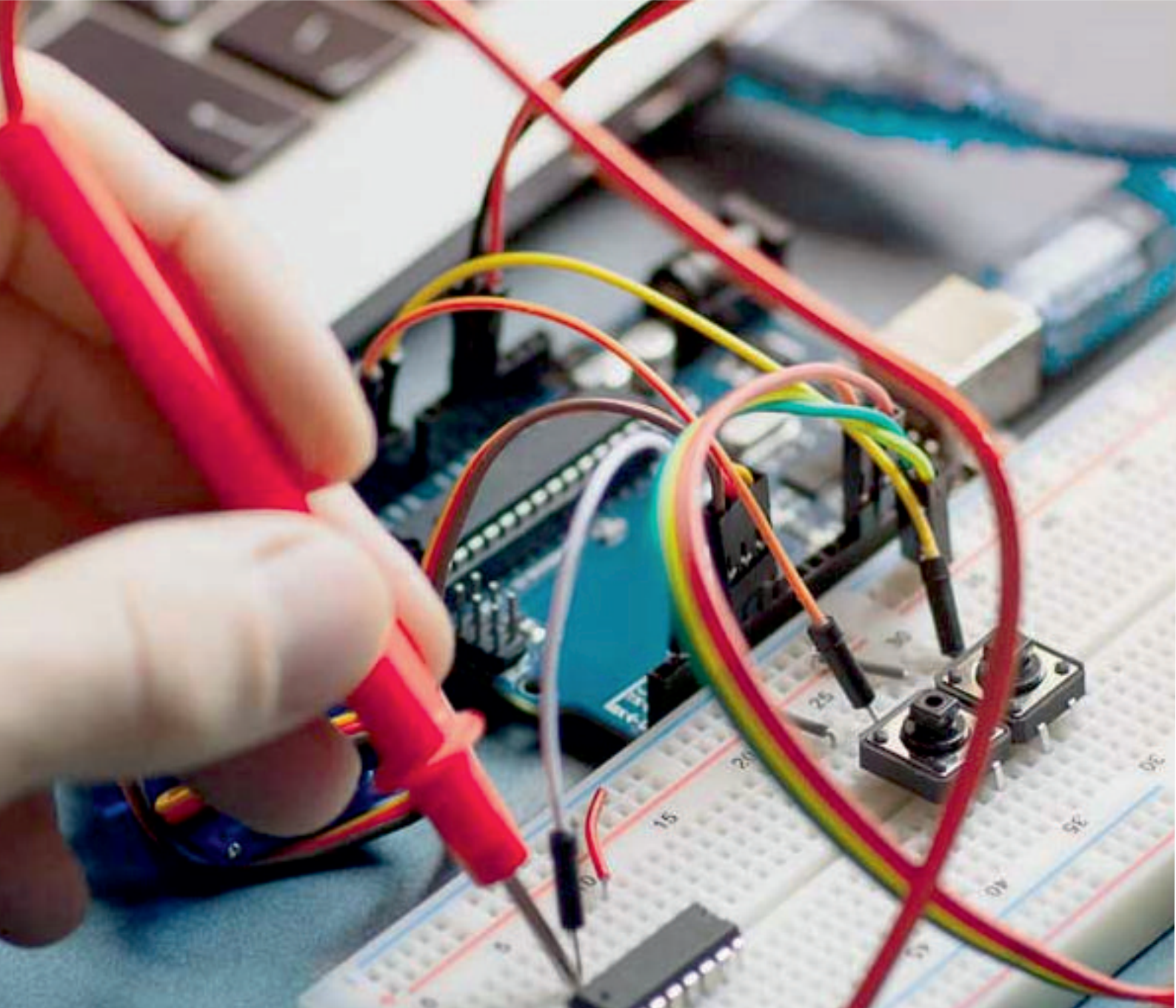

INNO  **SPACE**
SJIF Scientific Journal Impact Factor
Impact Factor: 7.282



ISSN INTERNATIONAL
STANDARD
SERIAL
NUMBER
INDIA



International Journal of Advanced Research

in Electrical, Electronics and Instrumentation Engineering

 **9940 572 462**  **6381 907 438**  **ijareeie@gmail.com**



www.ijareeie.com

Scan to save the contact details