



e-ISSN: 2278-8875
p-ISSN: 2320-3765

International Journal of Advanced Research

in Electrical, Electronics and Instrumentation Engineering

Volume 11, Issue 4, April 2022



Impact Factor: 8.18

9940 572 462

6381 907 438

ijareeie@gmail.com

www.ijareeie.com



Smart Integrated Automation System for Industrial and Domestic Purpose

Mudit Pratap Singh¹, Kritika Nath¹, Prabhat Mittal¹, Nitesh Upadhyaya¹

Department of Electronics and Communication, IMS Engineering College Ghaziabad, U.P, India

ABSTRACT: Automation device has a wide scope for this Generation as well as in the forthcoming generation. In this wide scope, Mobile communication technology is playing a major role in the world of automation but In today's world upgrading the automation system is a major concern. It became more costly when the automation system needs up-gradation. As a solution, we have successfully implemented a smart integrated automation system for both industrial and domestic purposes, by this system we can easily expand our existing automation system. This article is fully based on a low-cost and reliable automation system for accessing and controlling devices and appliances remotely using a NodeMCU-based Smartphone application. We worked with three major goals that are Provide an expendable automation circuit by user end, that can implement for both industrial and domestic automation and last, and this is open source re-programmable.

KEYWORDS: Automation System, NodeMCU, IR sensor.

I. INTRODUCTION

In the current world automation system has a wide scope and automation system is used world wide and becoming popular day by day but in this new technology many users are facing the problem of upgrading or expanding the existing automation system, which is challenging. If we consider the current scenario, if any user wants to expand their existing automation device they need to install another system device for that must be another Interfacing software. This is very challenging for any user. Automation is used by two techniques, i.e. manual and autonomous. In the case of a manual one, automation is controlled by the user, in the case of autonomous, it can be managed by observing the use and signal of the sensor and set time accordingly. So we come up with this idea to solve this challenge. Now our team proposed a solution to overcome this issue we plan and design an automation circuit that contains two NodeMCU that are based on the ESP8266 microcontroller. This project is divided into two sections- the first section is containing a relay circuit and a separated NodeMCU for Relay that is designed to give mobility for expanding the relay circuit at the user end which is helpful when user want to expand their existing relay automation board. The second part contains another NodeMCU with a sensor only that will be helpful when the user needs to add new sensors to an existing circuit. Both the NodeMCU clustered which means both the microcontroller are connected over the same server and internet. The reason for using a separated microcontroller is, i.e. User can upgrade the relay or sensor separately or it can be upgraded both at the same time. Our circuit system contains some sensors like an IR sensor, relay, and led display. That is used only for the demonstration and shows the working of sensors with the cluster NodeMCU system. In the Domestic automation system, we represent our home appliances are controlled via our phone applications, model is represented by the control of some bulbs via our mobile application, These bulbs are working on AC supply and the user can easily turn ON and OFF appliances via using the mobile. Another is industrial-based, in the industry we know that there are many sensors working at a time and our proposed design is capable to run with multi-sensors at a time without affecting Relay and Relay's NodeMCU.



II. BLOCK DIAGRAM

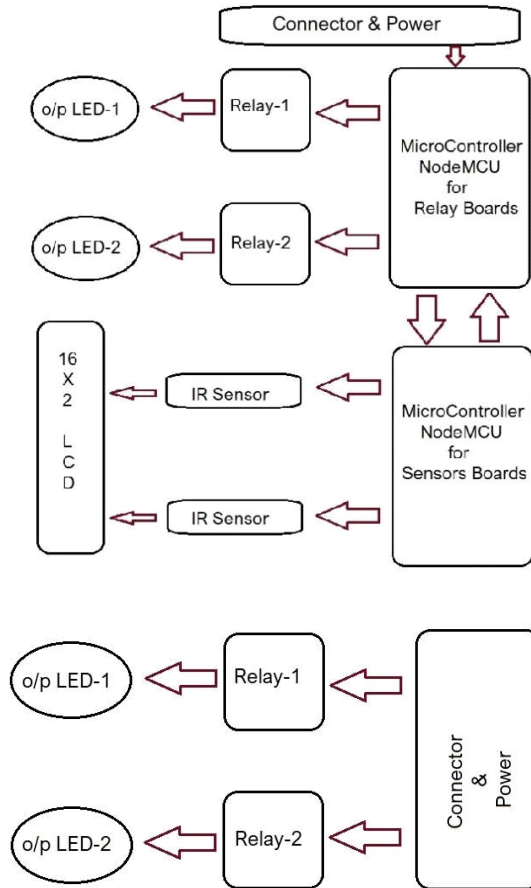

Fig 1: Block Diagram

III. COMPONENTS

3.1. NodeMCU

NodeMCU is an electronic device which is programmable at the user end according to their requirements. NodeMCU is an ESP8266-based microcontroller. NodeMCU boards are able to read input – light on sensors, a finger on a button, or a Twitter message- and turn it into an output – activating a motor, turning on a led, publishing something online. Node MCU has an integrated Wi-Fi module that makes it compatible to perform tasks over the internet. In this project, we use two NodeMCU microcontrollers, both microcontrollers are connected over the same server. One of the NodeMCU is used for relay module control which is able to control AC components and the second NodeMCU is used for sensors only. Specifications of Node MCU which is required in this project are as follows-

- Microcontroller-ESP-8266(32-bit) microcontroller
- Operating Voltage- 3.3v
- Input Voltage – 4.5v-10-v
- Analog pins-1
- Digital I/O pin-11
- Flash memory- 4 MB (0.5 kB for bootloader)
- SRAM - 64KB
- Frequency (clock speed) -80MHz

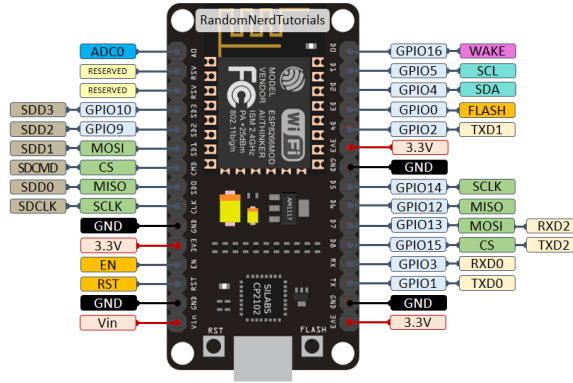

Fig 2: NodeMCU

3.2. Relay Sensor

Relay is a kind of electro-mechanical component that functions as a switch that is commonly used in the automatic control circuits and to control a high-current using a low-current signal. The input voltage of the relay signal ranges from 0 to 5V. The relay coil is energized by DC so that contact switches can be opened or closed. A single channel 5V relay module generally includes a coil, and two contacts, normally open (NO) and normally closed (NC). Working is done through a coil to magnetize the switch contacts & drag them jointly once activated. A spring drives them separately once the coil is not strengthened. By using this system there are mainly two benefits, the first one is, that the required current for activating the relay is less as compared to the current used by relay contacts for switching. The other benefit is, that both the contacts & the coil are isolated galvanically, which means there is no electrical connection among them.



Fig 2:Single-Channel Relay Module Specifications

Specification:

- Supply voltage – 3.75V to 6V
- Quiescent current: 2mA
- Current when the relay is active: ~70mA
- Relay maximum contact voltage – 250VAC or 30VDC
- Relay maximum current – 10A

**Advantages:**

- A remote device can be controlled easily
- It is triggered with less current but it can also trigger high power machines
- Easily contacts can be changed
- At a time, several contacts can be controlled using a single signal
- Activating part can be isolated
- It can switch AC or DC

3.3 IR Sensor

IR sensor is an infrared sensor that emits in order to sense some aspects of surroundings. It can measure the heat of the object as well as detects motion. It is one of the basic and popular sensor modules in electronic devices for counting purposes and detection in automation. This sensor is equivalent to human's visionary senses. This sensor should be fixed in such a way that it shall sense the obstacles. **An infrared sensor** is used to detect obstacles by transmitting **infrared** signals, this **infrared** signal is reflected from the surface of an object and the signal is received at the **infrared** receiver. The frequency range of infrared lies between the microwave and the visible light spectrum.

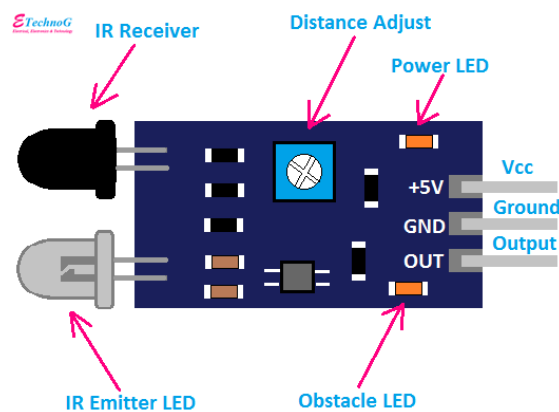
**3.4 16x2 LCD Module**

The term LCD stands for Liquid Crystal Display. It uses a plane panel technology, used in screens of computer monitors & TVs, smartphones, etc. It is an electronic device that is used to display data and the message is known as LCD 16x2. it includes 16 Columns & 2 Rows so it can display 32 characters (16x2=32) in total & every character will be made with 5x8 (40) Pixel Dots. 16 X2 displays mostly depend on multi-segment LEDs. There are different types of displays available in the market with different combinations such as 8x2, 8x1, 16x1, and 10x2, however, the LCD 16x2 is broadly used in devices, DIY circuits, electronic projects due to less cost, programmable friendly & simple to access. The basic working principle of LCD is passing the light from layer to layer through modules. These modules will vibrate & line up their position on 90o that permitting the polarized sheet to allow the light to pass through it. These molecules are accountable for viewing the data on every pixel. Every pixel utilizes the method of absorbing light to illustrate the digit. To display the value, the position of molecules must be changed to the angle of light.

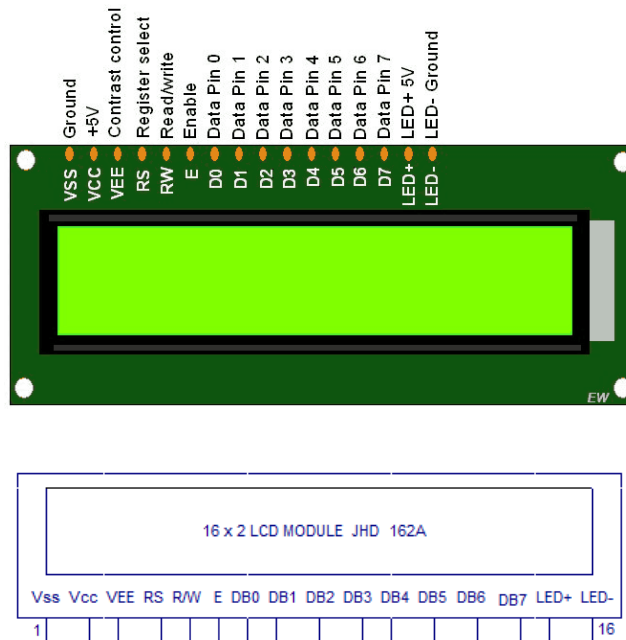

IV. METHODOLOGY

In this project, NodeMCU is used as the motherboard of the whole system. The first part of the system, which is basically the main system with a NodeMCU, is connected with 2 relay modules and also connected with another NodeMCU. The second NodeMCU is used for sensor control. The relay module enabled control of the AC component and this NodeMCU has the custom port to extend the relay module to 2 to 4(up to 14 relay modules). NodeMCU is programmed using Embedded C in such a way that, the user can reprogram just by adding some block of code which is also provided. In normal conditions, the user can control two AC components. In the second part of the system, the circuit board has the relay module and sensor ports in which users can install any kind of sensor like IR sensors, PIR sensors, temperature sensors, etc. For demonstration purposes, we use an IR sensor that is connected to the input port of NodeMCU and show output over the 16x2 LCD. The demonstration IR sensor counts the number of incoming and outgoing boxes. The second part of the system is an extended circuit board, which the user can use when he needs more relay module ports or sensor ports without changing the microcontroller.

V. RESULT

After the implementation of the proposed system user can upgrade and expand the automation system. In past, when users need to implement a new sensor or when they want to operate new AC components they need to install a whole new setup and it became too costlier and it is a complex process. In our proposed solution-based automation system whenever users want to upgrade, extend or install a new sensor they don't need to change the existing system they can implement it any time in the future. It saves the cost of the automation system and reduces the complexity of new setups.

VI. ADVANTAGES

- I. This project is helpful for both domestic and industrial automation expeditions.
- II. This project is user end upgradable and open-source reprogrammable.
- III. This project is connected with a Blynk IoT server that makes it a controllable world widely.
- IV. It is a separated sensor microcontroller that saves the cost of the sensor and reduces the complexity of implementation.



VII. CONCLUSION

The automation management system faces a great challenge in the form of continuous growth of technology and a lack of knowledge of users about the Internet of things. The conventional method is no longer effective enough for solving complex and challenging up-gradation of the automation systems. Due to the increased amount of automation systems and users, it is very important to take effective steps to reduce the complexity and make it user-end upgradable and open-source reprogrammable. This project replaces the conventional automation system from domestic and industry setup.

This project is able to operate and control all AC equipment that is present at home and in the industry (up to 220 volts) using only a relay module because sometimes users don't want to use any sensor in their custom automation, here our system is able to work without using any sensor, in case user want to use sensors in future, that is possible due to separated sensor microcontroller.

VIII. ACKNOWLEDGMENT

We would like to extend a special thanks to all our team members and those who have been directly or indirectly involved in making this project success, express our honest gratitude to our **Prof. Praveen Chaurasia** for his constant encouragement, inspiration, and guidance.

REFERENCES

1. <https://www.elprocus.com/arduino-sensor-types-and-applications/>
2. <https://www.engineersgarage.com/esp8266-wifi-controlled-solenoid/>
3. <https://en.wikipedia.org/wiki/NodeMCU>
4. <https://create.arduino.cc/projecthub/najad/using-arduino-ide-to-program-nodemcu-33e899>
5. https://en.wikipedia.org/wiki/Home_automation
6. <https://www.instructables.com/Interface-Relay-Module-With-NodeMCU/#:~:text=Relay%20is%20basically%20act%20a,based%20on%20NO%2DNC%20configuration.>
7. <https://electronicsforu.com/resources/learn-electronics/ir-led-infrared-sensor-basics>
8. https://www.researchgate.net/publication/354777128_IoT_based_Smart_Home_Automation_using_NodeMCU
9. https://www.researchgate.net/publication/275338025_Home_Automation_Systems_-_A_Study

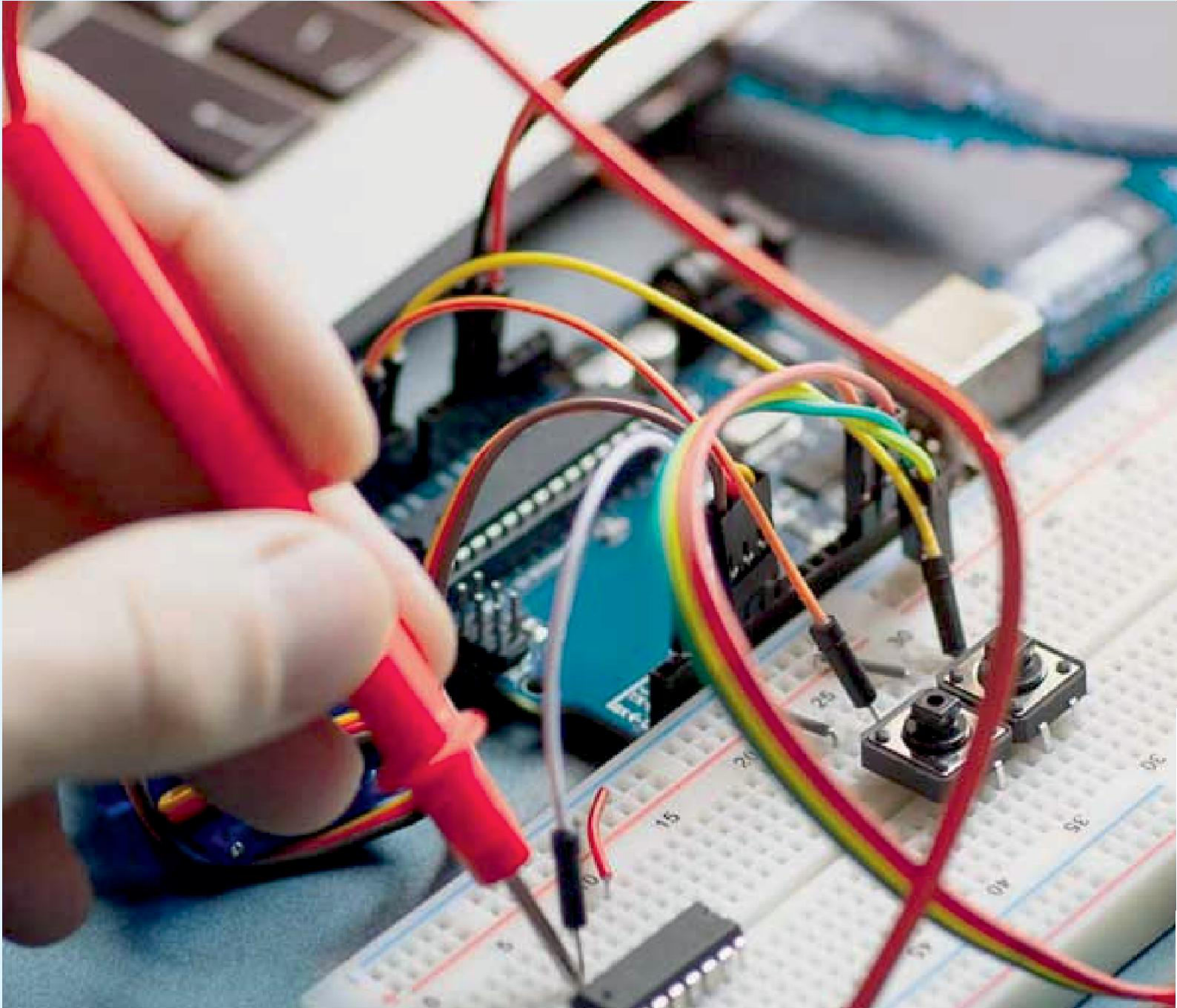

INNO  SPACE
SJIF Scientific Journal Impact Factor

Impact Factor: 8.18



ISSN INTERNATIONAL
STANDARD
SERIAL
NUMBER
INDIA



International Journal of Advanced Research

in Electrical, Electronics and Instrumentation Engineering

 9940 572 462  6381 907 438  ijareeie@gmail.com



www.ijareeie.com

Scan to save the contact details