



e-ISSN: 2278-8875  
p-ISSN: 2320-3765

# International Journal of Advanced Research

in Electrical, Electronics and Instrumentation Engineering

Volume 11, Issue 4, April 2022



Impact Factor: 8.18

9940 572 462

6381 907 438

ijareeie@gmail.com

www.ijareeie.com



# Power Factor Pre-regulation in Interleaved Luo Converter-Fed Electric Vehicle Battery Charger

J. Deena Dayalan<sup>1</sup>, D. Jagadeesan<sup>2</sup>, V. Suhash<sup>3</sup>, P. Tamil Arasan<sup>4</sup>

Department of Electrical and Electronics Engineering, SRM Valliammai Engineering College, Kattankulathur, Tamilnadu, India

**ABSTRACT:** A modified interleaved negative output elementary Luo converter to act as front-end power factor regulating converter for electric vehicle (EV) charger is proposed in this paper. The proposed converter is simple in design and offers non-inverted DC output voltage. It has the advantages of high efficiency, almost unity power factor, low AC source current ripple resulting in power quality enhancement, better DC load voltage regulation. Due to interleaved configuration, rating of circuit components gets greatly reduced. Also, minimum numbers of circuit components pave the way for simple system design of EV charger. The converter is designed to provide stable operation when subjected to sudden disturbance in load power/supply voltage. The simulation analysis is done using MATLAB/Simulink. A prototype of converter is built and tested. Better performance of the system obtained under power factor and low current ripple. Better performance of the system obtained under power factor and low current ripple.

**KEYWORDS:** Power Quality (PQ), PF Pre- Regulator, Interleaved Luo Converter, DCM mode.

## I. INTRODUCTION

With the significant development in battery technologies and power electronics, the automotive industries such as EVs (Electric Vehicles) have provided a wider platform for modern researchers to grab an opportunity for achieving the cleaner propelling power sources [1]. The high energy and fuel efficiency have become greater concern for manufacturers and EV consumers, which has catalysed the need of efficient battery chargers for EVs. To obtain the high efficiency and reliability during charging, the power factor correction (PFC) converters have become vital part of the modern EV chargers. The circuit OF traditional EV charger with input full bridge diode rectifier (DBR) and DC-DC converter can be used. To overcome the above PQ issues, the conventional boost and buck-boost PFC converters are incorporated at the front end, between DBR and DC-link capacitor. However, the addition of an extra converter in charger, adds to the number of total components. This affects the cost and size of the charger, which restricts the efficiency and reliability of the charger with increased weight. Therefore, single stage isolated AC-DC converters with input DBR, are more widely used in PFC applications at high-power rating.

Luo converter, a new stream of DC-DC converter, is enticed by many researchers. Many more configurations of DC-DC Luo converter are detailed in literature.31–35 Voltage lifting techniques involved in Luo converter are quite commonly preferred for high gain operation. But the number of components is more in lifting configurations of Luo converter. Super lift Luo converter provides reduced input and output ripple content, but it belongs to boost configuration. In comparison to conventional configurations like Zeta, SEPIC, and Cuk, Luo converter possess so many positive attributes like capable of providing reduced ripple content at output voltage and input current, high voltage transfer gain, and higher efficient system [1].



The literature presents many topologies for this purpose, but the synchronous buck converter is possibly the simplest available choice. However, it is not adequate for high-power applications considering that it employs only two switches that operate complementarily, resulting in poor efficiency in this case. On the other hand, bidirectional interleaved converters have been the scope of many recent works, in which it is possible to increase the processed power levels by adding more phases if necessary [2]. Prominent advantages also include reduced current stresses and improved thermal distribution, minimized dimensions of filter elements and alleviation of the effects of current ripple. For instance, a 16-phase interleaved converter is proposed in, which can operate at high frequency and power levels rated at tenths of kilowatts with high efficiency over a wide load range. Other topologies have also been proposed for EV applications, e.g., the interleaved double dual boost converter.

Even though it is capable of achieving wide conversion range, isolated drive circuitry must be employed to drive all four active switches. The bidirectional converter based on the three-state switching cell is also suggested in, although it requires six active switches and one autotransformer. Besides, it is better recommended for applications where high-voltage step- up/step down is mandatory. The bidirectional full-bridge converter can also be considered as an option when galvanic isolation is required, but high component count and increased dimensions are major drawbacks [2]. For high-power applications, the interleaved converter seems to be a proper choice considering that the battery current is non-pulsating. Besides, interleaved structures are capable of achieving remarkable performance in EV applications due to reduced current.

**II. PROPOSED TOPOLOGY**

The high energy and fuel efficiency have become greater concern for manufacturers and EV consumers, which has catalyzed the need of efficient battery chargers for EVs. To obtain the high efficiency and reliability during charging, the power factor correction (PFC) converters have become vital part of the modern EV chargers.

By interleaving two Luo converter cells, the input current is divided between them, which provides reliable and efficient charging of the battery at high-power discontinuous conduction mode (DCM) operation. This reduces the switch conduction loss due to reduced device current stress and thus, the charger efficiency is improved.

The interleaved Luo converter incorporates low input and output current ripple due to ripple cancellation. This charger operates in constant current mode up to certain battery state of charge (SOC).

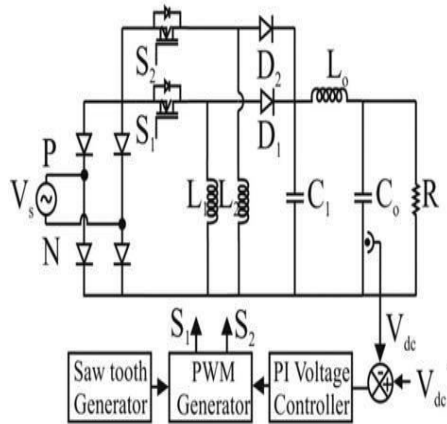

Fig 2.1 Basic Circuit of Interleaved Luo Converter



**III. IMPLEMENTATION OF INTERLEAVED LUO CONVERTER**

Figure 1 shows the circuit of proposed interleaved elementary Luo converter providing non- inverted output voltage. To limit harmonics distortion, EMI filter of low value is used. The control circuit is uncomplicated, possessing single voltage sensing loop. I-Lue controller with sawtooth is chosen for controlling DC link voltage by processing error in DC link voltage signals[1]. Major goal is to design a simple, cost-effective front-end PFC converter offering unity input power factor, reduced line current harmonics and effective DC link voltage regulation under universal AC voltage variation/wide variation of load power. Totally, four modes of operation can be realized in the proposed interleaved Luo converter, which are explained in the forthcoming section

- A. First mode operation shows the first operating mode of proposed interleaved Luo converter. Initially, inductor (L2) and capacitor (C1) are assumed to be fully charged. Here, switch (S1) is in ON state, so that inductor (L1) is charged up. Meanwhile, inductor (L2) and capacitor (C1) discharge their stored energy to inductor (L0) and so the current through (L0) increases gradually. Capacitor (C0) delivers power to the load.

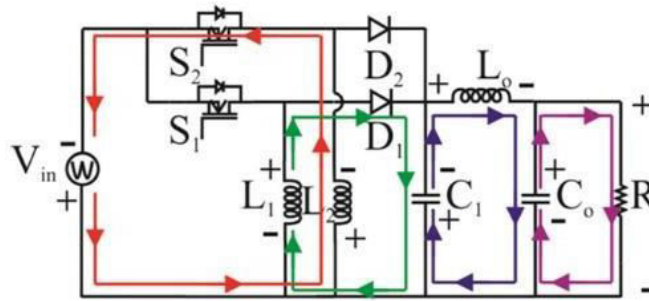

Fig3.1 First Mode

- B. Second mode operation Second operating mode of proposed converter is described in following figure. Switch (S1) is turned off, and so inductor (L1) starts discharging its stored energy to capacitor (C1) via diode (D1). Meanwhile, inductor (L0) delivers its stored energy to meet the load demand. Inductor (L2) imparts DCM operation as it transferred its whole energy.

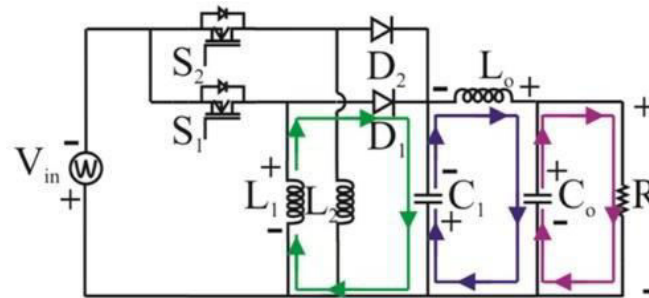

Fig3.2 Second Mode

- C. Following figure represents the third operating mode of proposed converter. In this mode, switch (S2) is turned ON exactly at a 180 phase shift from on time of switch (S1) which ensures the interleaved control operation.



Here, inductor (L2) is getting charged since switch (S2) being in ON state. Inductor (L1) and capacitor (C1) discharge their stored energy to charge the output inductor (L0). Capacitor (C0) delivers power to the load.

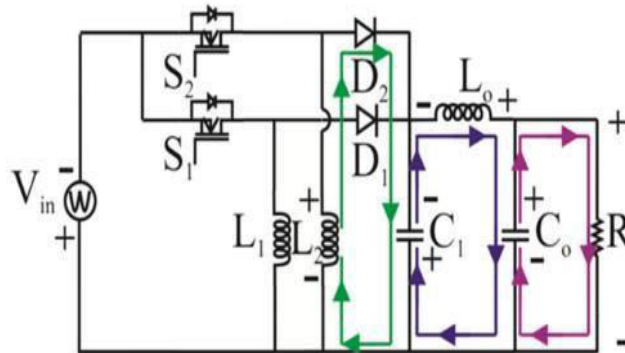

Fig3.3Third Mode

- D. Fourth mode operation Similar to second mode, inductor (L2) discharges its stored energy to charge up the capacitor (C1) via diode (D2). Inductor (L0) discharges its stored energy to meet the load demand. As discharged its whole energy, inductor (L1) current becomes discontinuous and offers DCM operation of converter during this mode.

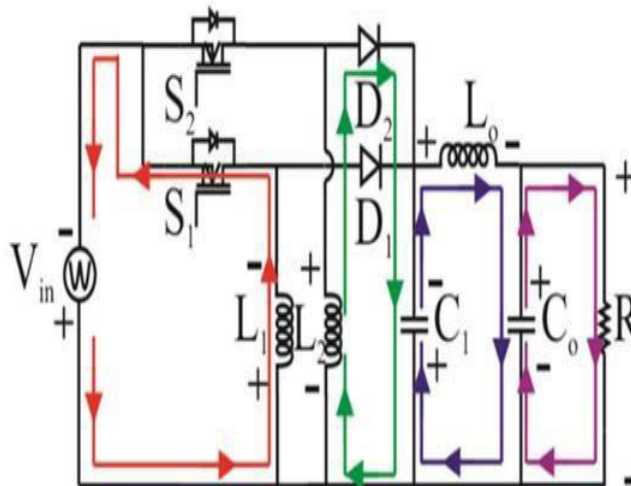

Fig3.4Fourth Mode



#### IV. HARDWARE AND SOFTWARE IMPLEMENTATION

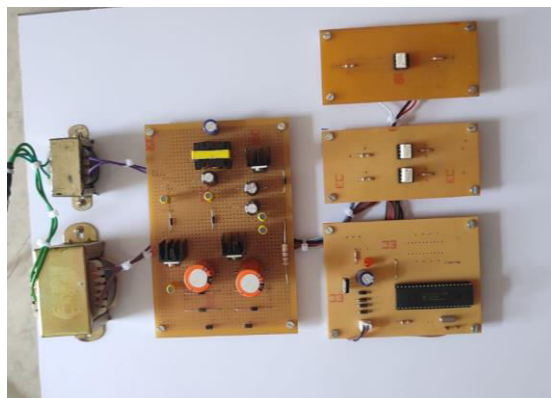

Fig 4.1 Hardware setup

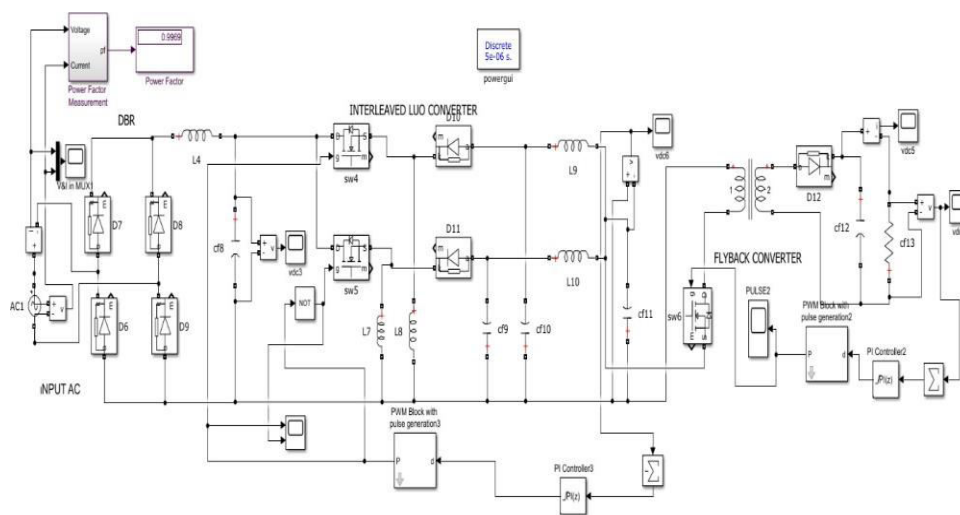

Fig 4.2 Simulation Diagram

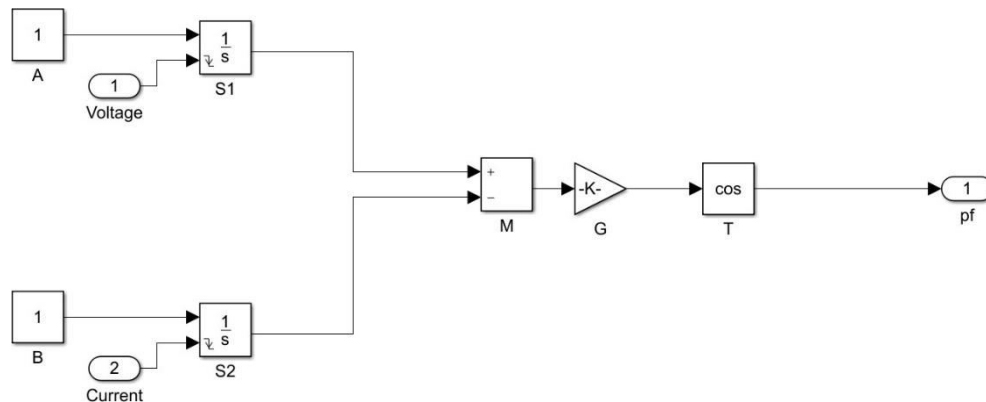

Fig 4.3 Power Factor Measurement

V. RESULTS AND DISCUSSION

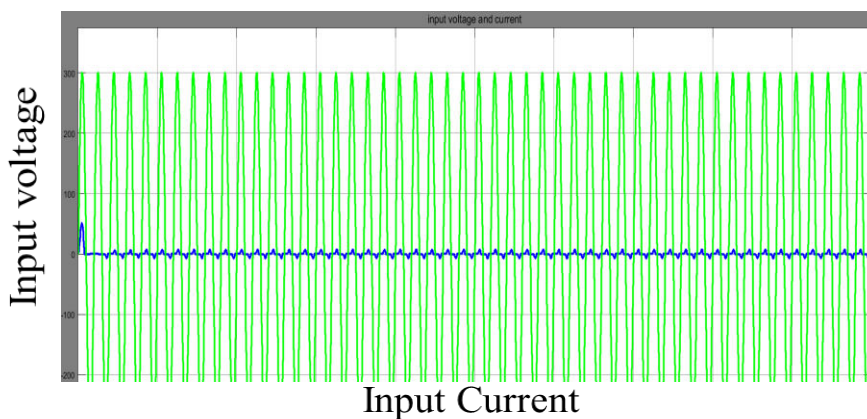

Fig 5.1 Input voltage And Current For Luo Converter

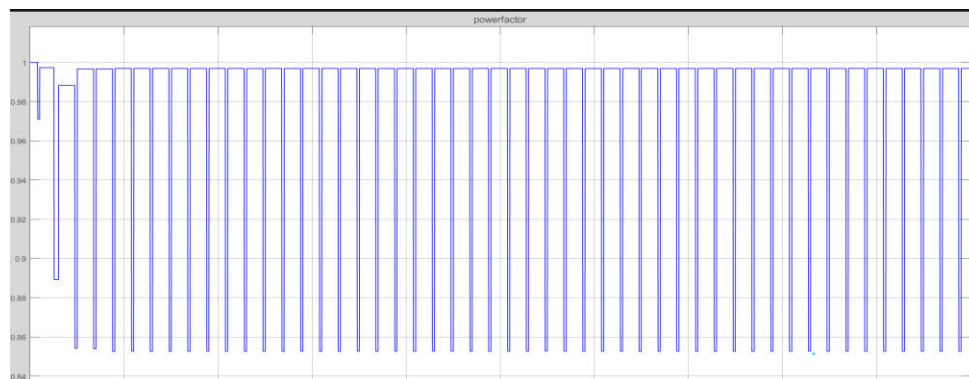

Fig 5.2 Power Factor Without Using Luo Converter

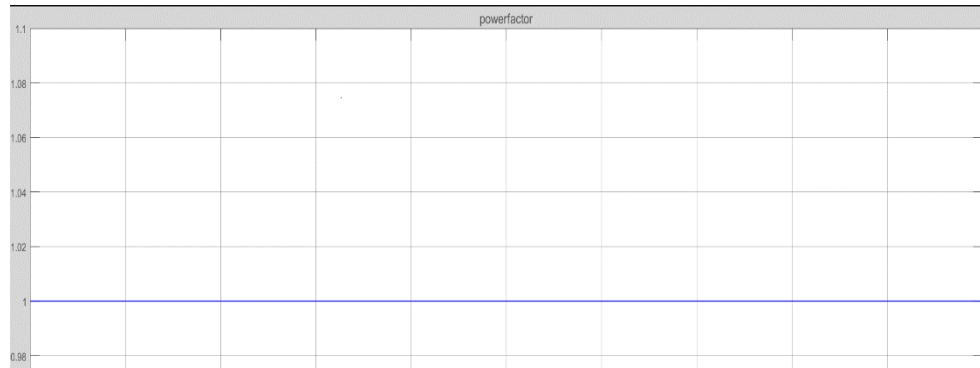

Fig 5.3 Power Factor Using Luo Converter

This graphical waveform represents the power factor obtained from the ac input side.

## VI. CONCLUSION

The design of an improved PQ based EV charger using a Interleaved Luo converter has been proposed to charge an EV battery under wide varying supply voltage and loadings. The proposed EV charger facilitates an integrated advantage of reduced devices stresses in single stage converter, simple control due to DCM operation and improved charging with isolation. The device voltage is reduced as compared to conventional isolated PFC converter-based charger and clamped at maximum input voltage; therefore, the reliability of the charger is improved, and it provides lower current ripple which is the desirable factor for power factor correction. Moreover, the size as well as cost of the charger is reduced. The effectiveness of proposed charger for built-in PF correction capabilities at mains, is tested at rated steady state and at wide range of varying line voltages. Therefore, the proposed improved PF based interleaved Luo converter features to be reliable, commercially cost effective and most viable solution for EV charging..

## REFERENCES

- [1] R. Kushwaha and B. Singh, "Bridgeless Isolated Zeta–Luo Converter-Based EV Charger With PF Preregulation ", IEEE Transactions on Industry Applications, Vol. 57, No. 1, pp. 628-636, Jan.-Feb. 2021, Doi: 10.1109/TIA.2020.3036019.
- [2] Radha Kushwaha and Bhim Singh, "Design and Development of Modified BL Luo Converter for PQ Improvement in EV Charger", IEEE Transactions on Industry Applications, Vol. 56, No. 4, pp. 3976 - 3984, July-Aug. 2020, Doi: 10.1109/TIA.2020.2988197.
- [3] S. Xu, Q. Shen, C. Wang, D. Ding and W. Sun, "A Digital Control Scheme for PSR Flyback Converter in CCM and DCM", IEEE Journal of Emerging and Selected Topics in Power Electronics, Vol. 8, No. 3, pp. 2837-2849, Sept. 2020, Doi: 10.1109/JESTPE.2019.2905637.
- [4] Hui Zhao, Yanfeng Shen and Wucheng Ying, " A Single- and Three-Phase Grid Compatible Converter for Electric Vehicle On-Board Chargers", IEEE Transactions on Power Electronics, Vol.35, No. 7, pp. 7545 - 7562, July 2020, Doi: 10.1109/TPEL.2019.2956653





- [5] H. Xu, D. Chen, F. Xue and X. Li, "Optimal Design Method of Interleaved Boost PFC for Improving Efficiency from Switching Frequency, Boost Inductor, and Output Voltage", IEEE Transactions on Power Electronics, Vol. 34, No. 7, pp. 6088-6107, July 2019, Doi: 10.1109/TPEL.2018.2872427.
- [6] Yang Xiao, Chunhua Liu and Feng Yu, "An Integrated On-Board EV Charger with Safe Charging Operation for Three-Phase IPM Motor", IEEE Transactions on Industrial Electronics, Volume: 66, Issue: 10, Oct. 2019, pp. 7551 - 7560, Doi: 10.1109/TIE.2018.2880712.
- [7] Radha Kushwaha and Bhim Singh, "Power Factor Improvement in Modified Bridgeless Landsman Converter Fed EV Battery Charger ", IEEE Transactions on Vehicular Technology, Volume: 68, Issue: 4, April 2019, pp. 3325 - 3336, Doi: 10.1109/TVT.2019.2897118.
- [8] H. Cheng, Y. Chang, C. Chang, S. Hsieh and C. Cheng, "A novel high-power-factor AC/DC LED driver with dual flyback converters", IEEE Journal of Emerging and Selected Topics in Power Electronics, Volume: 7, Issue: 1, March 2019, Doi: 10.1109/JESTPE.2018.2809450.
- [9] Vítor Monteiro, João C. Ferreira and Andrés A. Nogueiras Meléndez, "Experimental Validation of a Novel Architecture Based on a Dual-Stage Converter for Off-Board Fast Battery Chargers of Electric Vehicles", IEEE Transactions on Vehicular Technology, Volume: 67, Issue: 2, Feb. 2018, pp. 1000 - 1011, Doi: 10.1109/TVT.2017.2755545.
- [10] S. Kulasekaran and R. Ayyanar, "A 500-kHz 3.3-kW power factor correction circuit with low-loss auxiliary ZVT circuit", IEEE Transaction on Power Electronics, Vol. 33, No. 6, pp. 4783-4795, Jun. 2018, Doi: 10.1109/TPEL.2017.2737660.
- [11] A. Malschitzky, F. Albuquerque, E. Agostini and B. N. Claudinor, "Single-stage integrated bridgeless-boost nonresonant half-bridge converter for led driver applications", IEEE Transaction on Industrial Electronics, Vol. 65, No. 5, pp. 3866-3878, May 2018. Doi: 10.1109/TIE.2017.2760842.
- [12] Y. Jeong, J. K. Kim and G. W. Moon, "A bridgeless dual boost rectifier with soft-switching capability and minimized additional conduction loss", IEEE Transaction on Industrial Electronics, Vol. 65, No. 3, pp. 2226-2233, Mar. 2018, Doi: 10.1109/TIE.2017.2736489.
- [13] H. Wu, G. K. H. Pang, K. L. Choy and H. Y. Lam, "An optimization model for electric vehicle battery charging at a battery swapping station", IEEE Transaction on Vehicular Technology, Vol. 67, No. 2, pp. 881- 895, Feb. 2018, Doi: 10.1109/TVT.2017.2758404.
- [14] A. Ahmad, M. S. Alam and R. Chabaan, "A Comprehensive Review of Wireless Charging Technologies for Electric Vehicles", IEEE Transactions on Transportation Electrification, Vol. 4, No. 1, pp. 38-63, March 2018, Doi: 10.1109/TTE.2017.2771619.
- [15] M. Alam, W. Eberle, S. G. Deepak, C. Botting, N. Dohmeier and F. Musavi, "A hybrid resonant pulse-width modulation bridgeless AC–DC power factor correction converter", IEEE Transaction on Industry Applications, Vol. 53, No. 2, pp. 1406-1415, Mar./Apr. 2017, Doi: 10.1109/TIA.2016.2638806.
- [16] Zhicong Huang, Siu-Chung Wong and Chi K. Tse, " Design of a Single-Stage Inductive-Power-Transfer Converter for Efficient EV Battery Charging", IEEE Transactions on Vehicular Technology, Vol. 66, No. 7, pp. 5808 - 5821, July 2017, Doi: 10.1109/TVT.2016.2631596.
- [17] J. Yi, W. Choi and B. Cho, "Zero-Voltage-Transition Interleaved Boost Converter With an Auxiliary Coupled Inductor", IEEE Transactions on Power Electronics, Vol. 32, No. 8, pp. 5917-5930, Aug. 2017, Doi: 10.1109/TPEL.2016.2614843.
- [18] Z. Liu, B. Li, F. C. Lee and Q. Li, "High-Efficiency High-Density Critical Mode Rectifier/Inverter for WBG-Device-Based On-Board Charger", IEEE Transactions on Industrial Electronics, Vol. 64, No. 11, pp. 9114-9123, Nov. 2017, Doi: 10.1109/TIE.2017.2716873.
- [19] M. Alam, W. Eberle, D. S. Gautam and C. Botting, "A soft-switching bridgeless AC–DC power factor correction converter", IEEE Transaction on Power Electronics, Vol. 32, No. 10, pp. 7716-7726, Oct. 2017, Doi: 10.1109/TPEL.2016.2632100.
- [20] C. Shi, H. Wang, S. Dusmez and A. Khaligh, "A SiC-based high-efficiency isolated onboard PEV charger with ultrawide DC-link voltage range", IEEE Transaction on Industry Applications, Vol. 53, No. 1, pp. 501- 511, Jan./Feb. 2017, Doi: 10.1109/TIA.2016.2605063.



- [21] D. Patil and V. Agarwal, "Compact onboard single-phase EV battery charger with novel low-frequency ripple compensator and optimum filter design", IEEE Transaction on Vehicle Technology, Vol. 65, No. 4, pp. 1948-1956, Apr. 2016, Doi: 10.1109/TVT.2015.2424927.
- [22] Chuan Shi, Alireza Khaligh and Haoyu Wang, "Interleaved SEPIC Power Factor Preregulator Using Coupled Inductors In Discontinuous Conduction Mode With Wide Output Voltage", IEEE Transactions Industry Applications, Vol. 52, No. 4, pp. 3461-3471, July–Aug, 2016. Doi: 10.1109/TIA.2016.2553650.
- [23] C. Chang, C. Cheng, E. Chang, H. Cheng and B. Yang, "An Integrated High-Power-Factor Converter With ZVS Transition", IEEE Transactions on Power Electronics, Vol. 31, No. 3, pp. 2362-2371, March 2016, Doi: 10.1109/TPEL.2015.2439963.
- [24] E. E. Roussineau, "Design, Simulation And Implementation Of A 500W Single-Phase CCM Boost PFC", IEEE Latin America Transactions, Vol. 14, No. 6, pp. 2623-2630, June 2016, Doi: 10.1109/TLA.2016.7555229.
- [25] C. C. Mi, G. Buja, S. Y. Choi and C. T. Rim, "Modern Advances in Wireless Power Transfer Systems for Roadway Powered Electric Vehicles", IEEE Transactions on Industrial Electronics, Vol. 63, No. 10, pp. 6533-6545, Oct. 2016, Doi: 10.1109/TIE.2016.2574993.

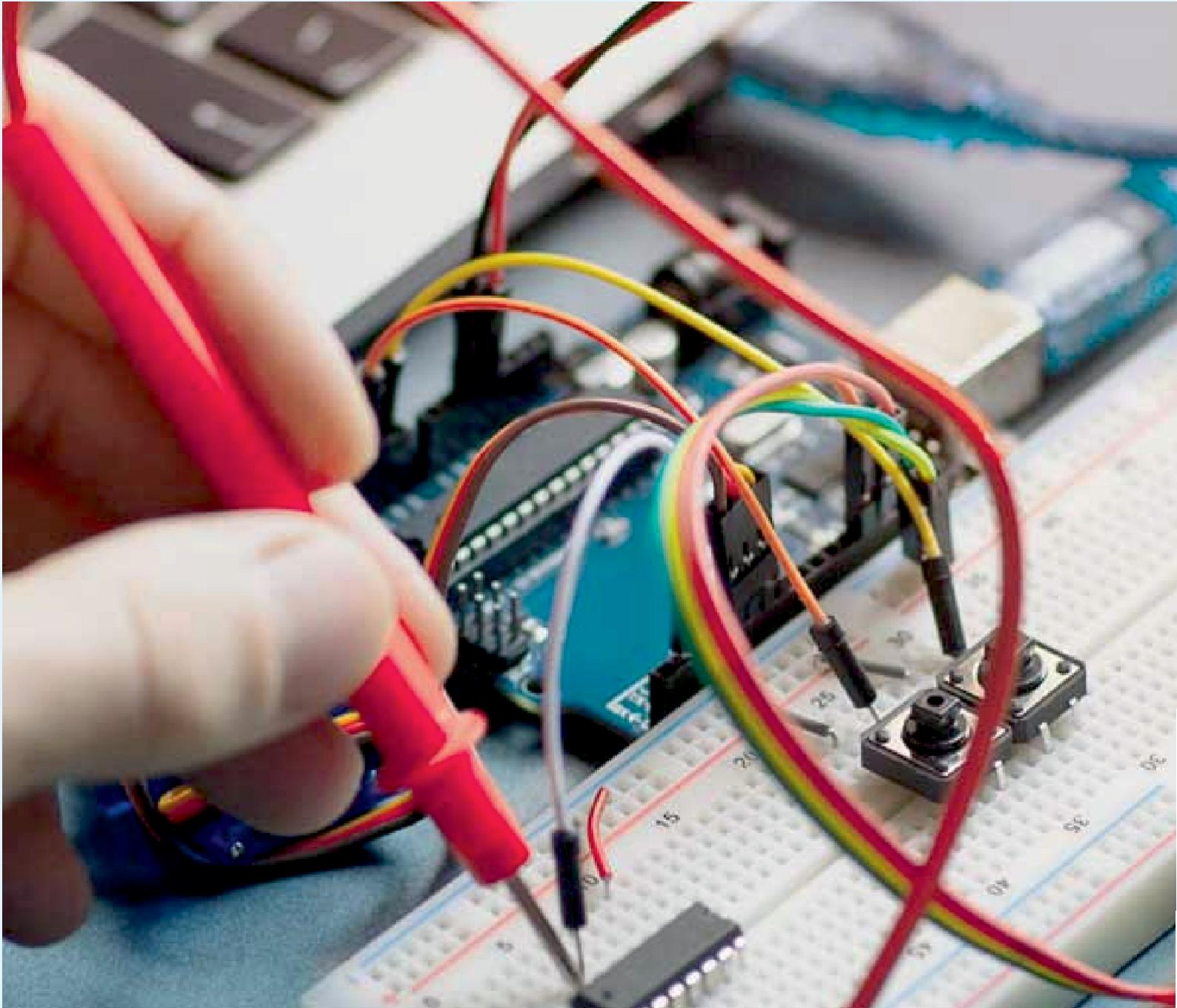

INNO  SPACE  
SJIF Scientific Journal Impact Factor

Impact Factor: 8.18

 **doi**<sup>®</sup>  
**cross** **ref**

 **INTERNATIONAL  
STANDARD  
SERIAL  
NUMBER  
INDIA**



# International Journal of Advanced Research

in Electrical, Electronics and Instrumentation Engineering

 9940 572 462  6381 907 438  [ijareeie@gmail.com](mailto:ijareeie@gmail.com)



[www.ijareeie.com](http://www.ijareeie.com)

Scan to save the contact details