



e-ISSN: 2278-8875

p-ISSN: 2320-3765

International Journal of Advanced Research

in Electrical, Electronics and Instrumentation Engineering

Volume 10, Issue 10, Octoberber 2021

ISSN INTERNATIONAL
STANDARD
SERIAL
NUMBER
INDIA

Impact Factor: 7.282

☎ 9940 572 462

☑ 6381 907 438

✉ ijareeie@gmail.com

@ www.ijareeie.com



Survey on Reactive Power Sharing for Smart Power Grid Flexibility

Mahesh Kumar^{1*}, Prof. Siddharth Shukla²

M. Tech. Scholar, Department of Electrical and Electronics Engineering, TIT & Science, Bhopal, India¹

Assistant Professor, Department of Electrical and Electronics Engineering, TIT & Science, Bhopal, India²

ABSTRACT: A micro-grid approach plays an enormous role in the increased penetration of renewable energy resource into grid thus reducing the emissions due to large coal fired power plants. The energy management in micro-grid is a challenging task as a major share of the generation is from Renewable Energy Sources. Usually, there are Power electronic interfaces through which the local generators are connected to the micro-grid which enables the control capabilities such as generation-demand management through active reactive power control, synchronization of the inverter to grid, meeting the power quality standards for the injected currents, maximum power point tracking etc. The active-reactive power delivered by the inverter is controlled by current control with the objective of the steady state and transient state performance requirements.

KEYWORDS:- PV Array, Wind Power, Micro-grid

I. INTRODUCTION

A well-known fact is that, in micro grids several renewable energy sources and conventional energy sources operate together. The switching in and switching out of any distributed generator will cause variation in the structure and model of the micro-grid at any point of time during the operation. So, it becomes necessary to ensure that the control structure and its action should be independent of the system and the operating conditions. From the discussions above, it is clear that intense testing of micro-grids in both the component level and configuration level is very important in the aspect of investigation and demonstration of the adequacy of the design. The testing is to be carried out both under steady state conditions and during transient conditions. To simulate various network configurations under specific input-output conditions, real-time simulators i.e. emulators are vital. Emulators give the flexibility of obtaining different energy flows, creating fault conditions, creating transient conditions help understanding the electricity distribution networks meticulously. For example, micro-grids working under islanded mode, the dynamics are very fast as there are no significant time constants present within the network. The unpredictability of supply and demand is very common under islanded condition, which puts the stability and efficiency of the network under threat and test. Most of the generators are nature driven, and so for consistent performance of the interfacing power converters and the control loops, the experiments need to be repeated for every load/grid condition at every possible input condition. With an actual renewable energy source, it is not practical to repeatedly set the steady state and transient ambient conditions at all ambient values as required. Thus, emulators representing any renewable energy source are primarily intended as a power source to the converters in experiments to verify the 18 reliability and repeatability of operation of the converter in steady state as well as in transient conditions of all possible input/grid conditions. Such a hardware simulator has to produce outputs effectively as will be given by a renewable energy source at any operating condition. Besides the renewable source emulator, the system emulators are also very much crucial in the development of fail-safe micro-grids. System emulators will have the network parameters for the actual spread length corresponding to micro-grids represented by lumped circuit parameters, thus allows the testing of various generators operating on it in a synchronized manner under various conditions. By the use of these emulators the smart grid system designers will get the response from low cost, safe, and easily configurable simulators and emulators instead of waiting for expensive and hardwired deployments for their testing. This will make the micro-grids to be operator-centered and operator-friendly.

II. MICROGRID STRUCTURE

Microgrid solar PV and wind generation system become very attractive solution in particular for stand-alone applications. Combining the two sources of solar and wind can provide better reliability and their hybrid system becomes more economical to run since the weakness of one system can be complemented by the strength of the other



one. The integration of hybrid solar and wind power systems into the grid can further help in improving the overall economy and reliability of renewable power generation to supply its load. Similarly, the integration of hybrid solar and wind power in a stand-alone system can reduce the size of energy storage needed to supply continuous power. Solar electricity generation systems use either photovoltaics or concentrated solar power. The focus in this paper will be on the photovoltaics type. Detailed descriptions of the different technologies, physics and basics of PV can be found in many textbooks and papers such as [4-7]. Kurtz [8] pointed out that ten years ago the concentrator cell was only ~30% efficient compared with more than 40% today with the potential to approach 50% in the coming years. Si cells have efficiencies of 26% and multi-junction III-V-compound cells have efficiencies above 45% (48% in the laboratory) as pointed out in reference [9]. PV modules produce outputs that are determined mainly by the level of incident radiation. As the light intensity increases, photocurrent will be increased and the open-circuit voltage will be reduced [10]. The efficiency of any photovoltaic cell decreases with the increasing temperature which is non-uniformly distributed across the cell [11]. The solar output power can be smoothed by the distribution of solar power in different geographical areas [12]. Electricity from solar PV and concentrated solar power plants is significantly expensive and requires significant drop in cost or change in policies by either subsidizing or forcing the use of these technologies to be able to achieve significant market penetration [13]. Global wind report (2012) indicated that the annual market grew by around 10% to reach around 45 GW and the cumulative market growth was almost 19% [14]. Detailed descriptions of the wind energy can be found in references [4] and [15]. Wind turbines (WTs) are classified into two types: horizontal-axis WT (HAWT) and vertical-axis WT (VAWT). The highest achievable extraction of power by a WT is 59% of the total theoretical wind power [15]. Hybrid solar-wind systems can be classified into two types: grid connected and stand-alone. Literature reviews for hybrid grid connected and stand-alone solar PV and wind energies were conducted worldwide by many researchers who have presented various challenges and proposed several possible solutions. Due to the nature of hybrid solar PV and wind energies, optimization techniques can play a good role in utilizing them efficiently. Graphic construction methods [16], linear programming [17-18], and probabilistic approach [19] are few examples of optimization techniques that have been developed for techno-economically optimum hybrid renewable energy system for both types. Luna-Rubio et al. [20] conducted a review of existing research of optimal sizing of renewable hybrids energy systems with energy storage components for both stand-alone and grid-connected systems. The authors gave brief descriptions about those indicators and the different sizing methods. A review of control strategies for a hybrid renewable energy system was carried out in [21] and another review was done in [22] for optimization of hybrid renewable energy system with more focus on wind and solar PV systems. The reviews in [21] and [22] are applicable for both types; grid-connected and stand-alone systems.

III. CONTROL OF MICROGRID

The control strategies for microgrid depend on the mode of its operation. The aim of control technique should be to stabilize the operation of microgrid. When designing a controller, operation mode of MG plays a vital role. Therefore, after modelling the key aspect of the microgrid is control.

1. Control of Grid Connected

In grid connected mode, microgrid acts as a controllable load/source. It should not actively regulate the voltage at the point of common coupling (PCC). Its main function is to satisfy its load requirements with good citizen behavior towards main grid. The balance between generation and demand, control of the parameters of the system is taken care by the utility grid. The voltage and frequency reference of the microgrid is also set by the main grid. Therefore the main task of a DG unit is to control the output real power (P) and reactive power (Q).

2. Control Islanded Microgrid

In islanded mode, the reactive power sharing is highly dependent on impedance of power line. Due to the different distances among DERs interface converters (DICs), the equivalent transmission line impedance could be unequal [51]. P_f and QV droop characteristics are used in DER interface converters for power sharing operations. The P_f droop control provides an accurate real power sharing among the DIC's but the problem arises in QV droop control. Because of this unequal impedance load sharing performance of QV control can be affected.

IV. GRID CONNECTED SYSTEM

The integration of combined solar and wind power systems into the grid can help in reducing the overall cost and improving reliability of renewable power generation to supply its load. The grid takes excess renewable power from renewable energy site and supplies power to the site' loads when required. Fig. 1 and Fig. 2 show the common DC and common AC bus grid-connected to solar PV and wind hybrid system, respectively



Power electronics topologies and control

There are two topologies for grid-connected solar PV and wind hybrid system as can be seen from Fig. 1 and Fig. 2. Fig. 1 shows that the DC outputs' voltages from individual solar PV, wind and battery bank stream, through individual DC/DC and AC/DC units, are integrated on the DC side and go through one common DC/AC inverter which acts as an interface between the power sources and the grid to provide the desired power even with only one source available. Hence, the renewable energy sources act as current sources and can exchange power with the grid and the common DC/AC inverter controls the DC bus voltage. The individual units can be employed for maximum power point tracking (MPPT) systems to have the maximum power from the solar PV and wind systems and the common DC/AC inverter will control the DC bus voltage.

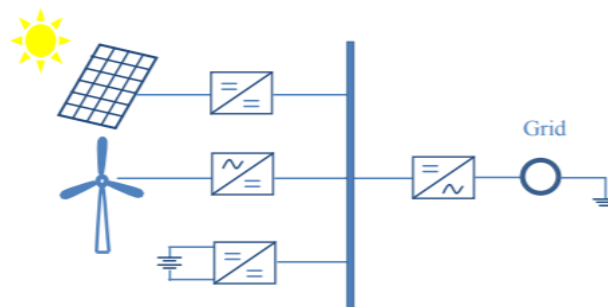

Figure 1: Grid-connected hybrid system at common DC bus

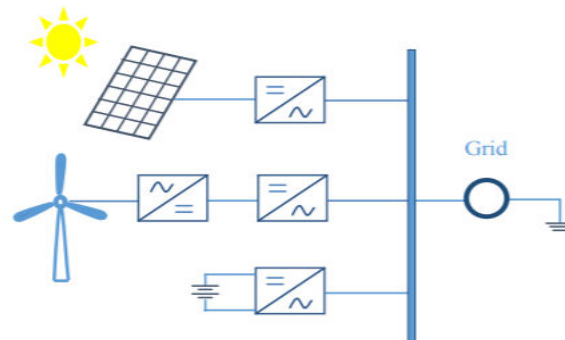

Figure 2: Grid-connected hybrid system at common AC bus

The battery bank is charged when there is an extra power and discharged (by supplying power) when there is shortage of power from the renewable energy sources. On the other hand, Fig. 2 shows that renewable energy sources are injecting power directly to the grid through individual DC/AC and AC/DC-DC/AC units.

Power quality

The increased penetration of grid-connected renewable energy sources has an impact on the grid power quality in particular weak grids. Voltage fluctuation, frequency fluctuation and harmonics are major power quality issues. Furthermore, intermittent energy from solar PV and wind has a huge impact on network reliability. However, accurate forecasting and scheduling systems can minimize the impacts. Various statistical forecasting and regression analysis approaches and algorithms are used to forecast weather pattern, solar radiation and wind speed [12-13]. System operator can adjust other dispatch able generation elsewhere in a system to deal with any deficit or surplus power from renewable power generation [14]. This will reduce the impact of the fluctuations from the generation of the renewable energy sources. In addition, the distribution of RES to larger geographical area in small units instead of large unit concentrating in one area can control the intermittence effect of power generation from RES [15]. Energy storage devices like batteries or Uninterruptable Power Supply (UPS) can work as a balancing devices that provide power when there is an energy deficiency in renewable generation and store excess energy when there is surplus power from renewable generation [16-17]. Active power filters such as dynamic voltage regulators, static synchronous compensators and unified power quality conditioners can be used to resolve voltage fluctuation [18], [19]. Similarly, power compensators such as fixed or switched capacitor can be used to resolve reactive power issue [20]. They are the latest interfacing devices between grids and consumer appliances. Sudden changes in active power drawn by a load could cause system frequency fluctuation in AC grids. These changes represent unbalance situations between load and



generation. In view of the above, it is important to design control loops for power and frequency control to mitigate quality issues [21]. Bae and Kwasinski highlighted that a primary goal of a pulse width modulation (PWM) inverter controller was to regulate three-phase local AC bus voltage and frequency in a microgrid. Harmonics are normally caused by power electronics devices and non-linear appliances. Appropriate filters and PWM switching converter can be used to mitigate harmonic's distortion.

Stand-alone (autonomous) system

The stand-alone or autonomous power system is an excellent solution for remote areas where utilities facilities, in particular transmission lines, are not economical to run or difficult to install due to their high cost and/or difficulties of terrain, etc. The stand-alone systems can be sub-classified into common DC bus or common AC bus. The strength of one source could overcome the weakness of the other during a certain period of time [22]. For stand-alone applications, storage cost still represents the major economic issue. Combining both PV solar and wind powers can minimize the storage requirements and ultimately the overall cost of the system [23]. Increasing PV panels and capacity of wind turbines could be a better choice compared to the increasing of batteries since batteries are much more expensive with a shorter lifespan compared to the life time of a PV or WT. However, for high reliability systems, too few batteries can't meet the reliability requirements, which will incur more cost since too many PV modules or too large WTs will be required [24]. For a small islanded electricity system in New Zealand, with winter peaking demand, I. G. Mason found that the average storage ratio for solar PV to wind was 1.768:1 in comparison to 0.613:1 (residential) and 0.455:1 (farm dairy) with summer peaking demand. Integration of renewable energy generation with battery storage and diesel generator back-up systems is becoming cost-effective solution for resolving less usable renewable energy during the year. [25]. However, if storage runs out, there is no way of importing energy. Therefore, integrating PV and wind energy sources with fuel cells is a promising alternative back up energy source for hybrid generation systems. Distributed generators can help fluctuations in power supply since generations' units will be close to the loads. However, introducing distributed generators will require an up gradation in the existing protection schemes [26].

Optimization

As mentioned earlier, a combination of solar PV and wind sources improves overall energy output. However, energy storage system is required to have a continuous power supply and cover any deficiency in power generation from the renewable energy sources. The storage system can be battery banks, fuel cells, etc. with a more focus here on battery banks. Various optimization techniques have been reported which could be applied to reach a techno-economically optimum hybrid renewable energy system [16-19]. A comparison was made for many optimization techniques of hybrid systems in [18]. For remote areas which represent most of the standalone application for hybrid solar PV and wind systems, it is not always easy to find long-term weather data, such as solar radiation and wind speed that are used for sizing purposes. Hence, more artificial intelligence techniques such as fuzzy logic, genetic algorithms and artificial neural network are used for sizing standalone systems in comparison with traditional sizing method based on long-term weather data.

WIND ENERGY SYSTEMS

Wind energy has the biggest share in the renewable energy sector [1], [3]. Over the past 20 years, grid connected wind capacity has more than doubled and the cost of power generated from wind energy based systems has reduced to one-sixth of the corresponding value in the early 1980s [3]. The important features associated with a wind energy conversion system are:

- Available wind energy
- Type of wind turbine employed
- Type of electric generator and power electronic circuitry employed for interfacing with the grid.

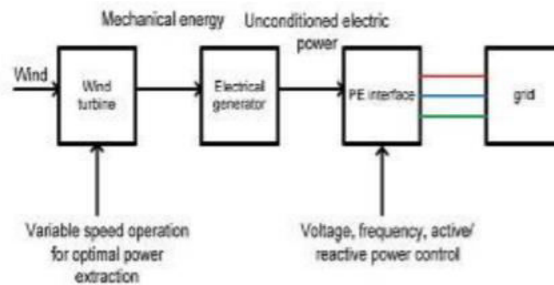

Figure 3: Variable speed wind energy conversion system

Wind energy – Wind speeds, air pressure, atmospheric temperature, earth surface temperature etc., are highly inter-linked parameters. Due to the inherent complexity, it is unrealistic to expect an exact physics based prediction methodology for wind intensity/sustainability. However, distribution based models have been proposed, and employed to predict the sustainability of wind energy conversion systems [4]. Detailed explanation of the wind energy resources is beyond the scope of this paper. Based on studies it has been reported that the variation of the mean output power from a 20 year period to the next has a standard deviation of less than 0.1 [4]. It can be concluded with reasonable confidence that wind energy is a dependable source of clean energy. Based on the aerodynamic principle utilized, wind turbines are classified into drag based and lift based turbines. Based on the mechanical structure, they are classified into horizontal axis and vertical axis wind turbines. With respect to the rotation of the rotor, wind turbines are classified into fixed speed and variable speed turbines. Presently the focus is on horizontal axis, lift based variable speed wind turbines [2], [3]. Power electronic circuits play a crucial enabling role in variable speed based wind energy conversion systems. Fixed speed wind turbines are simple to operate, reliable and robust. However the speed of the rotor is fixed by the grid frequency. As result, they cannot follow the optimal aerodynamic efficiency point. In case of varying wind speeds, fixed speed wind turbines cannot trace the optimal power extraction point. In variable speed wind turbines, power electronic circuitry partially or completely decouples the rotor mechanical frequency from the grid electrical frequency, enabling the variable speed operation. The type of electric generator employed and the grid conditions dictate the requirements of the power electronic (PE) interface. Fig. 1 depicts a variable speed wind energy conversion system. The electrical generator popularly employed for partially variable speed wind energy conversion systems are doubly- fed- induction generators [5]. Fig. 2 depicts a doubly- fed induction- generator where the rotor circuit is controlled by the power converter system via the slip rings and the stator circuit is connected to the grid. This method is advantageous as the power converter has to handle a fraction ~ 25% - 50 % of the total power of the system [5]. The power converter system employs a rotor side ac- dc converter, a dc link capacitor, and a dc- ac inverter connected to the grid as shown in Fig.

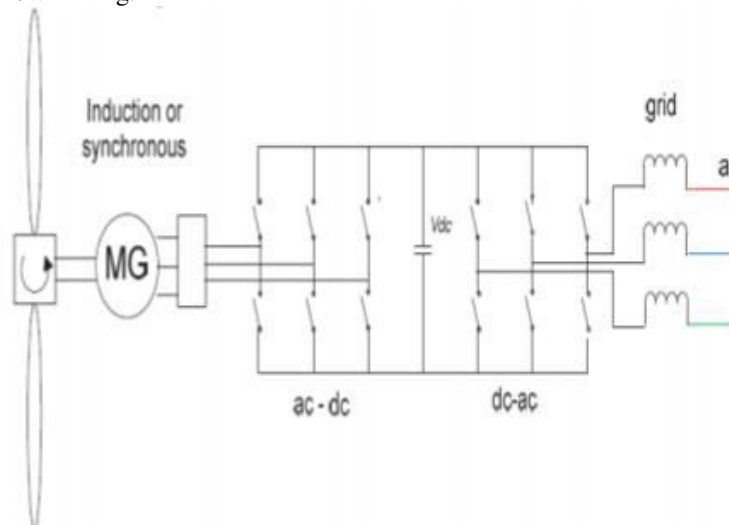

Figure 4: Fully variable wind energy conversion system



V. CONCLUSION

This paper has provided a review of challenges and opportunities on integrating solar PV and wind energy sources for electricity generation. The main challenge for grid-connected system as well as the stand-alone system is the intermittent nature of solar PV and wind sources. By integrating the two resources into an optimum combination, the impact of the variable nature of solar and wind resources can be partially resolved and the overall system becomes more reliable and economical to run. This definitely has bigger impact on the stand-alone generation. Integration of renewable energy generation with battery storage and diesel generator back-up systems is becoming a cost-effective solution for stand-alone type. The wind-battery-diesel hybrid configuration can meet the system load including peak times. Energy management strategies should ensure high system efficiency along with high reliability and least cost. Good planning with accurate forecasting of weather pattern, solar radiation and wind speed can help in reducing the impact of intermittent energy.

REFERENCES

- [1] Farshid Kamrani, Sajjad Fattaheian-Dehkordi, Ali Abbaspour¹, Mahmud Fotuhi-Firuzabad and Matti Lehtonen, "Investigating the Impacts of Microgrids and Gas Grid Interconnection on Power Grid Flexibility", Smart Grid Conference (SGC), IEEE 2019.
- [2] J. H. R. Enslin, "The role of power electronics and storage to increase penetration levels of renewable power," Power and Energy Society General Meeting - Conversion and Delivery of Electrical Energy in the 21st Century, IEEE Press, pp. 1-2, July (2008) DOI: 10.1109/PES.2008.4596958
- [3] O. Edenhofer, R. Pichs-Madruga and Y. Sokona, Eds., "Renewable energy sources and climate change mitigation," SRREN_FD_SPN_Final Report, <http://www.ipcc.ch/report/srren/>, (2012)
- [4] A. Luque and S. Hegedus, Ed., Handbook of photovoltaic science and engineering (Wiley, Chichester, 2003)
- [5] L. Freris, D. Infield, Renewable energy in power systems (Wiley, Chichester, 2008) [first edition]
- [6] B. Parida, S. Iniyar, and R. Goic, "A review of solar photovoltaic technologies" Renewable and Sustainable Energy Review, 15, 1625-1636 (2011) DOI: 10.1016/j.rser.2010.11.032
- [7] S. Kurtz, "Opportunities and challenges for development of a mature concentrating photovoltaic power industry," Technical Report NREL/TP-520-43208, Revised November (2009)
- [8] EPTP, "A strategic research agenda for photovoltaic solar energy technology," September (2011) [second edition]
- [9] [10] J. Karp, "Concentrating solar power: progress and trends," Jacobs School of Engineering, University of California San Diego, Triton SPIE/OSA, February 12 (2009)
- [10] L. Micheli, N. Sarmah, X. Luo, K. S. Reddy, and T. K. Mallick, "Opportunities and challenges in micro- and nano-technologies for concentrating photovoltaic cooling: A review" Renewable and Sustainable Energy Reviews, 20, 595-610 (2013) DOI: 10.1016/j.rser.2012.11.051
- [11] H. Zhang and L. L. Lai, "Research on wind and solar penetration in a 9- bus network" Proc. IEEE Power and Energy Society General Meeting, IEEE Press, pp. 1-6, July (2012) DOI: 10.1109/PESGM.2012.6345218
- [12] P. Komor, "Wind and solar electricity: challenges and opportunities," University of Colorado at Boulder, Pew Center on Global Climate Change, June (2009)
- [13] GWEC, "Global wind report annual market update 2012," http://www.gwec.net/wpcontent/uploads/2012/06/Annual_report_2012_LowRes.pdf, GWEC Report, April (2013)
- [14] K. Grogg, "Harvesting the wind: the physics of wind turbines," Carleton College, Physics and Astronomy Comps Papers 2005, <http://digitalcommons.carleton.edu/pacp/7>, April 13 (2005)
- [15] B. S. Borowy and Z. M. Salameh, "Methodology for optimally sizing the combination of a battery bank and PV array in a Wind/PV hybrid system" IEEE Transactions on Energy Conversion, 11, 367-375 (1996) DOI: 10.1109/60.507648
- [16] W. Kellogg, G. Venkataramanan, and V. Gerez, "Optimal unit sizing for a hybrid wind-photovoltaic generating system" Electric Power Systems Research, 39, 35-38 (1996) DOI: 10.1016/S0378-7796(96)01096-6
- [17] R. Chedid and Y. Saliba, "Optimization and control of autonomous renewable energy systems" International Journal Of Energy Research, 20, 609-624 (1996) DOI: 10.1002/(SICI)1099-114X(199607)20:7<609::AID-ER176>3.0.CO;2-O
- [18] S. H. Karaki, I. R. B. Chedid, and R. Ramadan, "Probabilistic performance assessment of autonomous solar-wind energy conversion systems" IEEE Transactions on Energy Conversion, 14, 766-772 (1999) DOI: 10.1109/60.790949



- [19] R. Luna-Rubio, M. Trejo-Perea, D. Vargas-Vázquez, and G. J. Ríos-Moreno, “Optimal sizing of renewable hybrids energy systems: A review of methodologies” *Solar Energy*, 86, 1077-1088 (2012) DOI: 10.1016/j.solener.2011.10.016
- [20] [21] P. G. Arul, V. K. Ramachandramurthy, and R. K. Rajkumar, “Control strategies for a hybrid renewable energy system: A review” *Renewable and Sustainable Energy Reviews*, 42, 597-608 (2015) DOI: 10.1016/j.rser.2014.10.062
- [21] B. Bhandari, K. T. Lee, G. Y. Lee, Y. M. Cho, and S. H. Ahn, “Optimization of hybrid renewable energy power systems: A review” *International Journal of Precision Engineering and Manufacturing - Green Technology*, 2, 99-112 (2015) DOI: 10.1007/s40684-015-0013-z
- [22] M. Esteban, Q. Zhang, A. Utama, T. Tezuka, and K. N. Ishihara, “Methodology to estimate the output of a dual solar-wind renewable energy system in Japan” *Energy Policy*, 38, 7793-7802 (2010) DOI: 10.1016/j.enpol.2010.08.039
- [23] H. H. Chen, H. Y. Kang, and A. H. I. Lee, “Strategic selection of suitable projects for hybrid solar-wind power generation systems” *Renewable and Sustainable Energy Reviews*, 14, 413-421 (2010) DOI: 10.1016/j.rser.2009.08.004
- [24] R. Dufo-López, J. L. Bernal-Agustín, and F. Mendoza, “Design and economical analysis of hybrid PV-wind systems connected to the grid for the intermittent production of hydrogen” *Energy Policy*, 37, 3082-3095 (2009) DOI: 10.1016/j.enpol.2009.03.059
- [25] G. M. Tina and S. Gagliano, “Probabilistic modelling of hybrid solar/wind power system with solar tracking system” *Renewable Energy*, 36, 1719-1727 (2011) DOI: 10.1016/j.renene.2010.12.001
- [26] S. Bhattacharjee and S. Acharya, “PV-wind hybrid power option for a low wind topography” *Energy Conversion and Management*, 89, 942-954 (2015) DOI: 10.1016/j.enconman.2014.10.065.

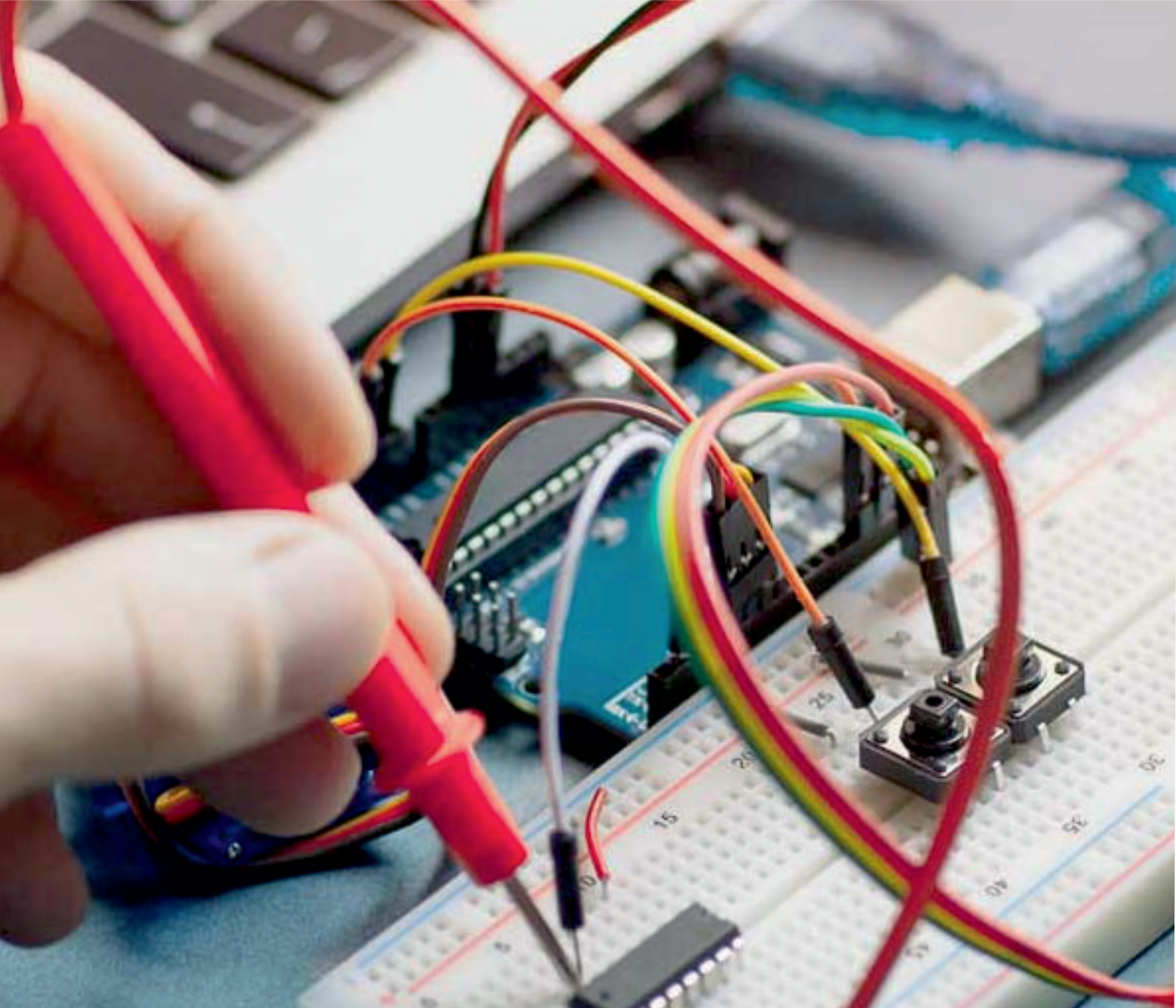

INNO  **SPACE**
SJIF Scientific Journal Impact Factor
Impact Factor: 7.282



ISSN INTERNATIONAL
STANDARD
SERIAL
NUMBER
INDIA



International Journal of Advanced Research

in Electrical, Electronics and Instrumentation Engineering

 **9940 572 462**  **6381 907 438**  **ijareeie@gmail.com**



www.ijareeie.com

Scan to save the contact details