



e-ISSN: 2278-8875
p-ISSN: 2320-3765

International Journal of Advanced Research

in Electrical, Electronics and Instrumentation Engineering

Volume 10, Issue 12, December 2021

ISSN INTERNATIONAL
STANDARD
SERIAL
NUMBER
INDIA

Impact Factor: 7.282



9940 572 462



6381 907 438



ijareeie@gmail.com



www.ijareeie.com



Classical and Intelligence Speed Control Techniques for Separately Excited DC Motor

M.J. Deshi¹, I.H. Usman², H.A. Mahdi³, M. Bako⁴, U. Aminu⁵

Department of Electrical Engineering, Abubakar Tafawa Balewa University Bauchi, Nigeria¹

Department of Electrical and Electronics Engineering Technology, Federal Polytechnic Bauchi, Nigeria^{2,3},

Department of Physics with Electronics Option, Plateau State Polytechnic Barkin Ladi, Jos, Nigeria⁴

Department of Mechatronics Engineering Technology, Federal Polytechnic Bauchi, Nigeria⁵

ABSTRACT: Most industrial process that uses DC Motor requires that DC Motor operates at a desired speed depending on the load and this speed should be sustained during the operational process however, a significant deviation from the desired speed trajectory was observed on the speed characteristic of DC Motor when acted upon by a load. This paper is aim at investigating the best controller for controlling the speed of a Separately Excited DC Motor in which four different controllers were deployed; the classical Proportional Integral (PI) Controller, Fuzzy Logic Controller (FLC), Artificial Neural Network (ANN) Based Controller and the Adaptive Neuro Fuzzy Inference System (ANFIS) Based Controller. The PI controller was designed by tuning its parameters in MATLAB Simulink in which the proportional and the integral gains were obtained for the best performance as 100.83 and 1750.45 respectively whereas the ANN and the ANFIS controllers were trained to mimic the desired plant input and output relationship. The FLC was designed to have single input which is the error signal and single output which is the speed using five membership function which give rise to five fuzzy rules based on Mamdani principle. A transient analysis was carried out on individual controllers using a speed reference of 1600 rpm to 2200 rpm in steps size of 200 rpm and it was observed that the ANFIS controller demonstrated a higher level of performance in tracking the input reference with an average percentage overshoot of 18.25%, a settling time of 1.446 seconds and a steady state error of 0.1%.

KEYWORDS: DC Motor, Speed, PI Controller, Fuzzy Logic Controller, ANFIS, ANN, NARMAL-L2

I. INTRODUCTION

In spite of the development in power electronics devices, the direct current motor is becoming very popular in our day to day life because its application is not only limited to industrial drives and in solar powered electric vehicles but also in household devices[1]. A DC motor is a device that converts electrical energy into mechanical work thereby making it easier to carry out a particular task. One way of classifying DC motors is by way of excitation of the field windings[2]; Self Excited DC Motor whose field coils are excited from the same DC source as does the armature coils and the Separately Excited DC Motor whose field coils received power from a source other than the armature voltage source[3]. In this work, a comparative study will be conducted on the speed control of a Separately Excited DC Motor using the classical Proportional Integral (PI) Controller and soft computing Intelligence controllers i.e., Fuzzy Logic Controller (FLC), Adaptive Neuro Fuzzy Inference System (ANFIS) Based Controller and the Artificial Neural Network (ANN) Based Controller in MATLAB and the Simulink environment. The speed of a DC motor can be control above and below its rated value by incorporating a controller[1]. There are two basic ways of controlling the speed of a DC motor [4] namely:

- i. Armature voltage control
- ii. Field current control

In armature voltage control of the speed of a DC motor, the voltage supply to the armature coils of the motor is varied while the field current is held constant whereas in field control of the speed of a DC motor, the armature voltage is held constant while the field excitation current is varied so as to vary the field flux. The Armature voltage control technique will be used in this work to control the speed of a Separately Excited DC Motor by using the classical PI controller and soft computing intelligent control i.e., FLC, ANN and ANFIS. The speed control of a separately excited DC motor is a non-linear process control and today lots of researchers are trying to find the most accurate and fastest controller for this process at a reduce cost. It was in this regard that the authors in[5] used a Fuzzy Logic Controller to control the



operation of a DC motor. Fuzzy Logic is based on the applications of fuzzy set in which linguistic variables are used rather than numeric data. Their aim was to designed and developed a Fuzzy Logic Controller in MATLAB Simulink for the speed control of a DC motor and they demonstrated that the speed of a DC motor can be control below and above its rated value using FLC. The authors in [6]also used a Fuzzy Logic Controller to control the speed of a DC Series Wound Motor which they demonstrated that the Fuzzy Logic Controller have the best performance index compared to DC motor without controller in terms of settling time (t_s), rise time (t_r), peak time (t_p) and percent overshoot (m_p). [7] present DC motor speed control using PID Controller and Fuzzy Rationale Controller. PID controller requires a mathematical model of the plant whereas the Fuzzy Logic Controller is based on intuitive reasoning and it was shown that the Fuzzy Logic Controller has least transient and robust state parameters, which shows that FLC is more efficient and viable as compared to PID controller. [2]applied Fuzzy and ANFIS controller in controlling the speed of a Separately Excited DC Motor. The observed parameters of interest include: input voltage of DC motor, speed, percentage overshoot and rise time of the output signal and the conclusion was ANFIS controller is better than Fuzzy controller as it has small percentage overshoot of about 8.2% and has a less distorted outputs against the Fuzzy controller which has an overshoot of 14.4%. Authors in [8]Carried out a simulation on the speed control of Separately Excited DC motor using Neuro-Fuzzy Controller. This controller is based on Adaptive Neuro Fuzzy Inference System (ANFIS) which was aimed at reducing peak over shoot and settling time of the DC Motor and they demonstrated that the performance with ANFIS controller outweigh that of the DC motor incorporating the conventional PI Controller. The authors in [9] Analyzed and designed the speed controller of a series wound DC motor using a non-linear PID controller and NARMA L-2 controllers. The speed of the DC motor was studied by giving set point inputs as speed and load torque was captured terms of step variation. After comparing the system response using NARMA L-2 Neuro Controller and conventional PID Controller, it was concluded that the NARMA L-2 Neuro Controller performed better in terms of rise time, overshoot and steady state error over non-linear PID controller. The author in [10]used Artificial Neural Networks (ANN) in estimating and controlling the speed of a Separately Excited DC Motor. The rotor speed of the DC motor was made to follow an arbitrarily selected trajectory. The Neural Network was designed based on two part: the first is the Neural Network Identifier which is to approximate the motor speed and the second is the Neural Controller which is to generate the control signal for the converter. The two neural networks were trained by Levenberg- Marquardt back-propagation algorithm and it was demonstrated that ANN techniques provide accurate control and ideal performance at real time.

II. SYSTEM DESIGN AND MODELING

A. Modeling of Separately Excited DC Motor

The circuit model of a separately excited DC motor is as shown in Fig 1.0. It has an electrical port for receiving the electrical input signal and a mechanical port for driving mechanical loads. The basic dynamics of the DC motor could be obtained by applying Kirchhoff’s laws on the model of Fig 1.0. The mechanical and the electrical model equations are given by eq. (1) and eq. (2) respectively as shown.

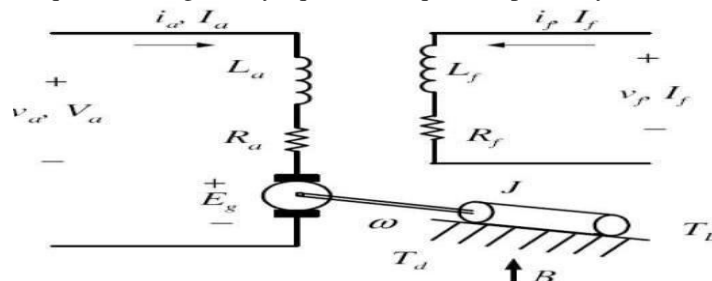

Fig 1.0: The Separately Excited DC Motor Model

$$v_a = L_a \frac{di_a}{dt} + R_a i_a + E_b \tag{1}$$

$$T_d = j \frac{d\omega}{dt} + B\omega + T_L \tag{2}$$

The Simulink model which captures the Separately Excited DC Motor model equations is as depicted in Fig.2.0 according to [10].

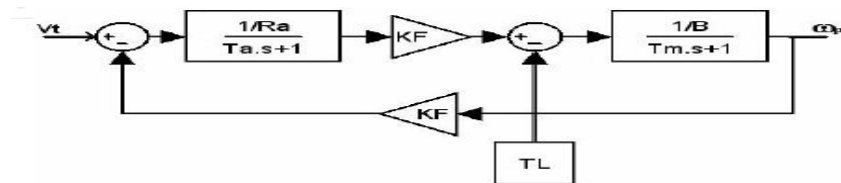

Fig 2.0: Separately Excited DC Motor Simulink Model

The Separately Excited DC Motor parameters adopted in this paper according to [10] are shown in Table 1

Table 1: Separately Excited DC Motor Parameters

Parameters	Description	Values
V_a	Armature Voltage	220 V
L_a	Armature Inductance	0.0025 H
R_a	Armature Resistance	0.5 Ω
J	Mechanical Inertia	0.0013 Kgm^{-2}
B	Damping Factor	0.001
T_L	Load Torque	21 Nm
ω	Rated Speed	1800 rpm

B. The Proportional Integral Controller

The three most commonly used type of classical controllers are; the Proportional (P) controller, Proportional Integral (PI) controller and the Proportional Integral Derivative (PID) controller. The proportional controller has good speed of response but suffers from poor steady state accuracy whereas the PI controller has a zero steady state error because of the integrator which is contained in its structure but considered as a sluggish controller because its speed of response is poor [11]. The Proportional Integral Derivative controller was introduced as a compromise between speed of response and steady state error. The PID controller output is defined by eq. (3).

$$u(t) = k_p e(t) + k_i \int e(t) dt + k_d \frac{d}{dt} e(t) \tag{3}$$

Where: $u(t)$ is the control signal, $e(t)$ is the error signal, k_p is the proportional time constant, k_i is the integral time constant and k_d is the derivative time constant. One of the disadvantages of the PID controller is its complex structure and its ability to inject noise into the control loop due to the presence of the derivative (D) component presents in its structure hence the need for filter arrangement at its output to suppress the noise injected by the system. The proportional integral controller was designed to improve the speed of response of the DC motor when acted upon by a disturbance load. The PI controller was designed by tuning its parameters in MATLAB Simulink so as to give the desired performance. The proportional gain constant k_p and the integral gain constant k_i were obtained after fine tuning the process and were found to be 100.83 and 1750.45 respectively. The PI controller Simulink model of the DC motor is shown in Fig 3.0.

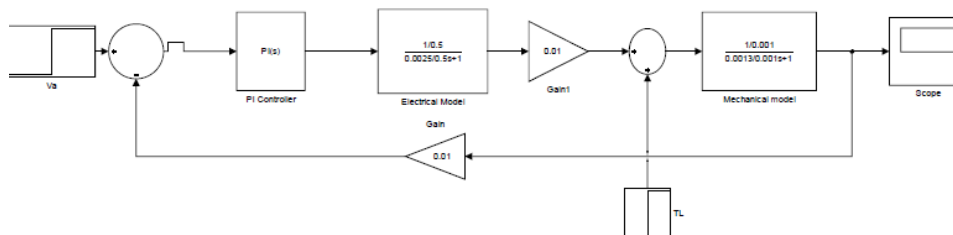

Fig 3.0: Proportional Integral Control of a Separately Excited DC Motor



C. The Fuzzy Logic Controller (FLC)

Fuzzy logic controller is a class of intelligent controllers mostly used in controlling non-linear processes. The fuzzy logic controller is based on the theory of fuzzy logic set [6] which uses discrete numbers in the set $\{0-1\}$ [6]. Fuzzy logic controller is similar to human’s feeling and deduction , the output of a fuzzy logic controller is obtained by fuzzifying the input and the output membership function [5]. Usually the crisp input of the fuzzy controller is processed into a member of the membership function which can be triangular membership function, trapezoidal membership function, sigmoidal membership function etc. Instead of using PI Controller to provide a control signal which is needed to control a plant, the Fuzzy Logic Controller could also be used because of it high level of intelligence to mimic the plant dynamics[12]. The Fuzzy controller is required when dealing with complex plant models, whose dynamics cannot be captured by mathematical equation especially for highly nonlinear processes control[6].In this paper, 5 membership functions correspondingto five linguistic variables were used to generate 5 Fuzzy rules for a single input single output fuzzy controller based on Mamdani principle [6]. The input variables was the error signal 'e' and the output variable was the control signal 'u'. The linguistic variables for the input and output variables were: Negative Large (NL), Negative Small (NS), Zero (Z), Positive Small (PS) and Positive Large (PL). Table 2.0 shows the fuzzy controller rules deployed in the controller design.

Table 2.0: The Fuzzy rules

Linguistic Input	Linguistic Output
NL	NL
NS	NS
Z	Z
PS	PS
PL	PL

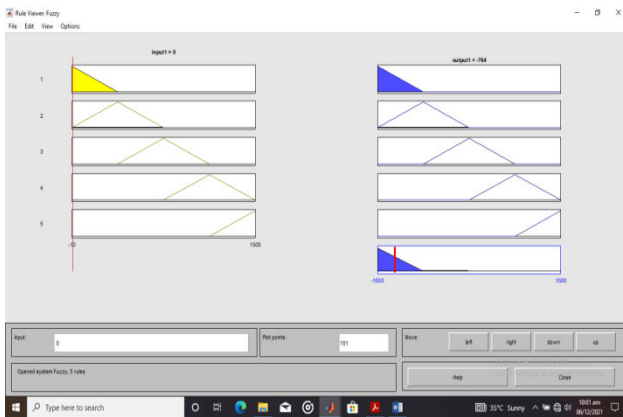

Fig 4.0: The Fuzzy Logic Controller Rule Viewer

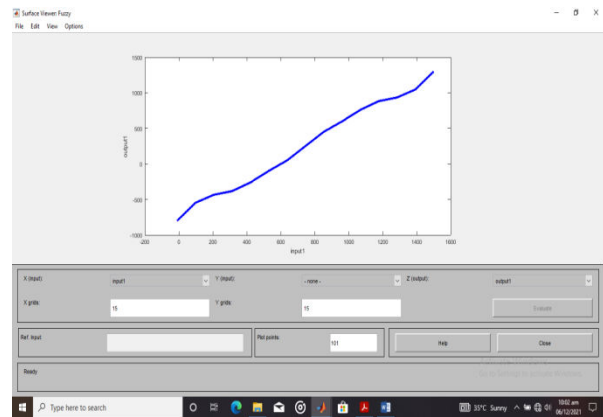

Fig 5.0: Fuzzy Logic Controller Surface Plot

The fuzzy controller rules viewer and the surface plot after it wassuccessfully designed in MATLAB and Simulink were depicted in Fig 4.0 and Fig 5.0 respectively and the Simulink model of the Separately Excited DC Motor incorporating the fuzzy controller is shown in Fig 6.0.

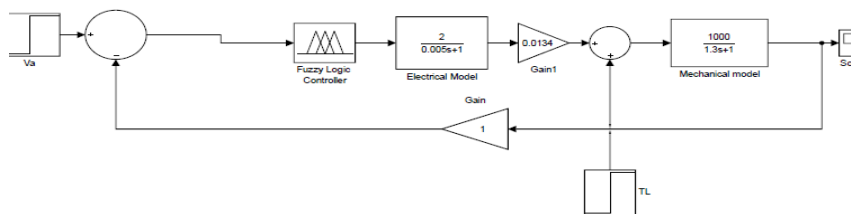

Fig 6.0: The Fuzzy Logic Control Model of a Separately Excited DC Motor



D. The Adaptive Neuro Fuzzy Inference System (ANFIS)

The Adaptive Neuro Fuzzy Inference System (ANFIS) which was developed in 1993, combines the learning ability of the Artificial Neural Network (ANN) and the deductive reasoning of the FLC in form of a hybrid intelligence unit that has the ability to automatically adapt and learn [1] from the plant. The basic idea about ANFIS controller is to provide a way for a fuzzy controller to learn to mimic the desired plant characteristics[1].The ANFIS model developed in this paper was trained using the data of Table 8 using the hybrid method which are shown in Fig 7.0 and Fig 8.0 and its structure and Simulink model are depicted in Fig 9.0 and Fig 10.0 respectively.

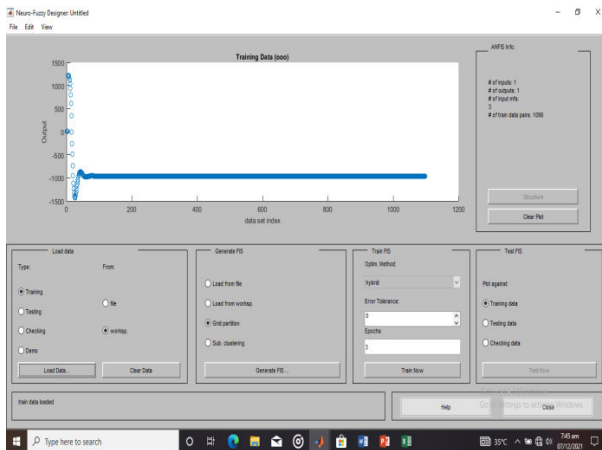

Fig 7.0: ANFIS Hybrid Training

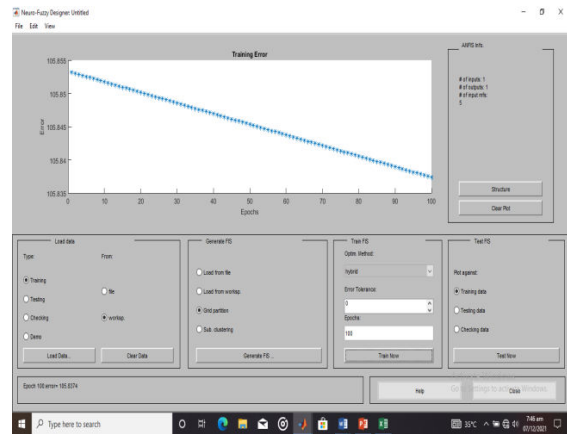
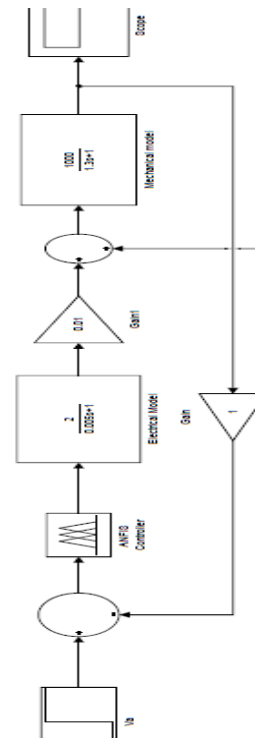
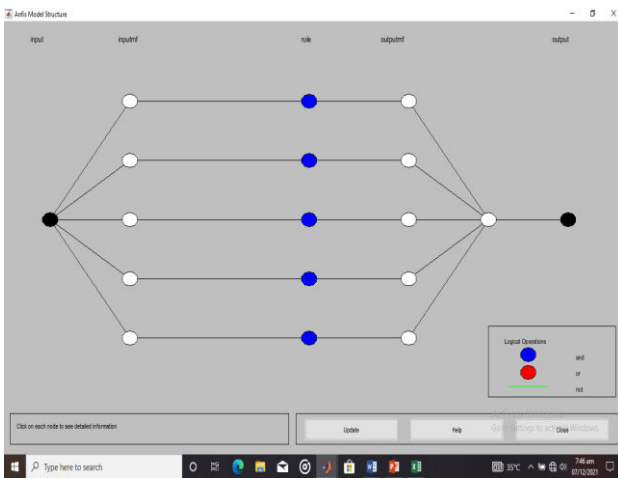

Fig 8.0: The ANFIS Training Error



E. The Artificial Neural Network Controller

The Artificial Neural Network (ANN) Controller is mostly used to identify and control non-linear dynamics process since it can mimic non-linear function to a desired degree of accuracy. To solve advance non-linear problem in control, two NARMA model could be used which are NARMA-L1 and NARMA-L2 [9]. The NARMA-L2 controller is simple to train because the controller is a simple rearrangement of Artificial Neural Network plant model [9]. The Neural network was trained using the data of Table 8 based on the feed-forward backpropagation and its structure and training regression model are shown in Fig 11.0. and Fig 12.0 respectively, and the Simulink model depicted in Fig 13.0

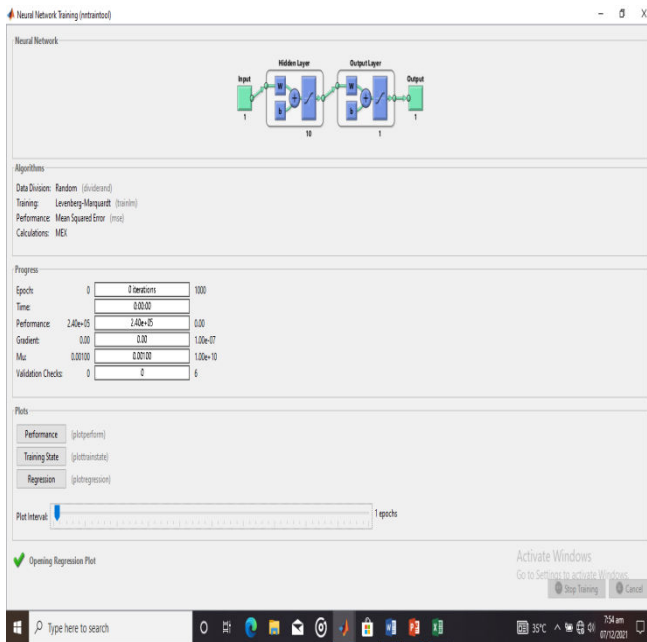

Fig 11.0: ANN Training and Structural Representation

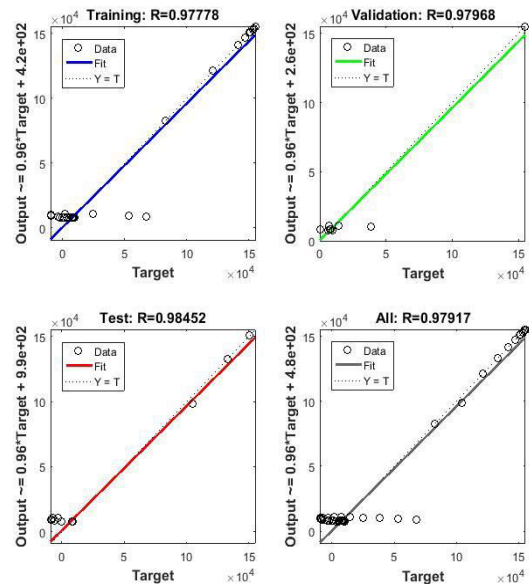

Fig 12.0: ANN Regression Model

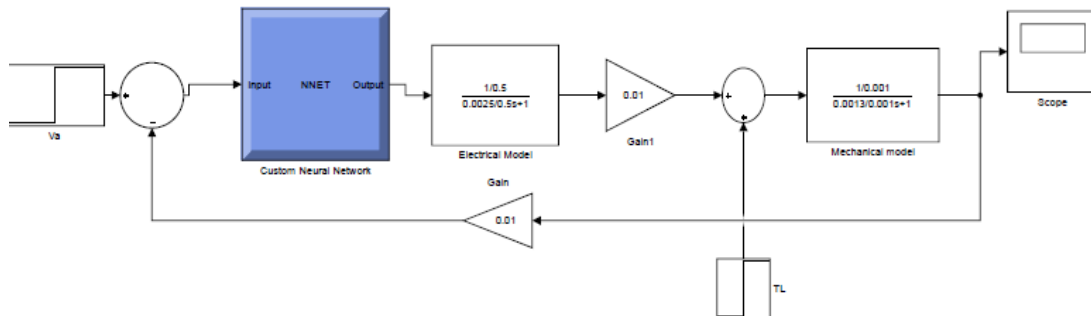

Fig 13.0: The Artificial Neural Network Model of a Separately Excited DC Motor

III. RESULTS AND DISCUSSION

The response of the Separately Excited DC Motor was simulated in MATLAB and its Simulink environment for the DC motor running above and below its rated speed of 1800 rpm and the step responses were shown in Fig 14.0, Fig 15.0, Fig 16.0 and Fig 17.0 respectively when carrying a load of 21 Nm.

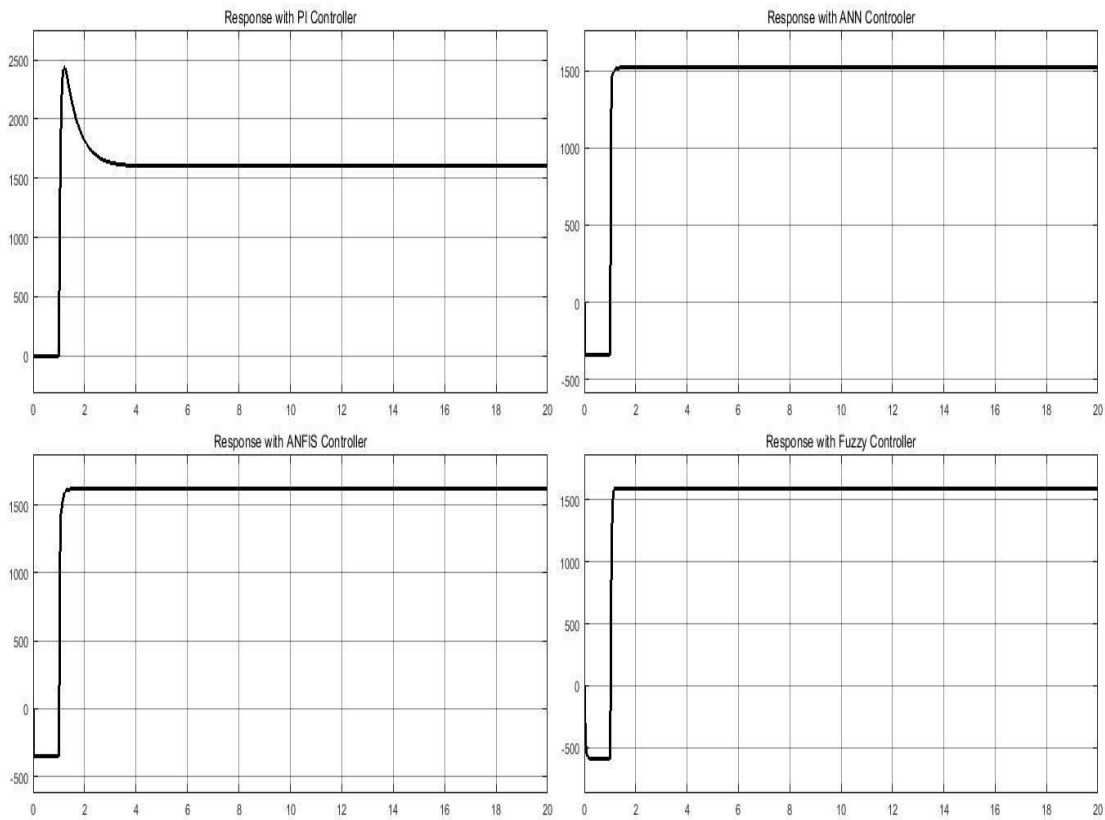

Fig 14.0: Transient Response of the Controllers at 1600 rpm (Below rated speed)

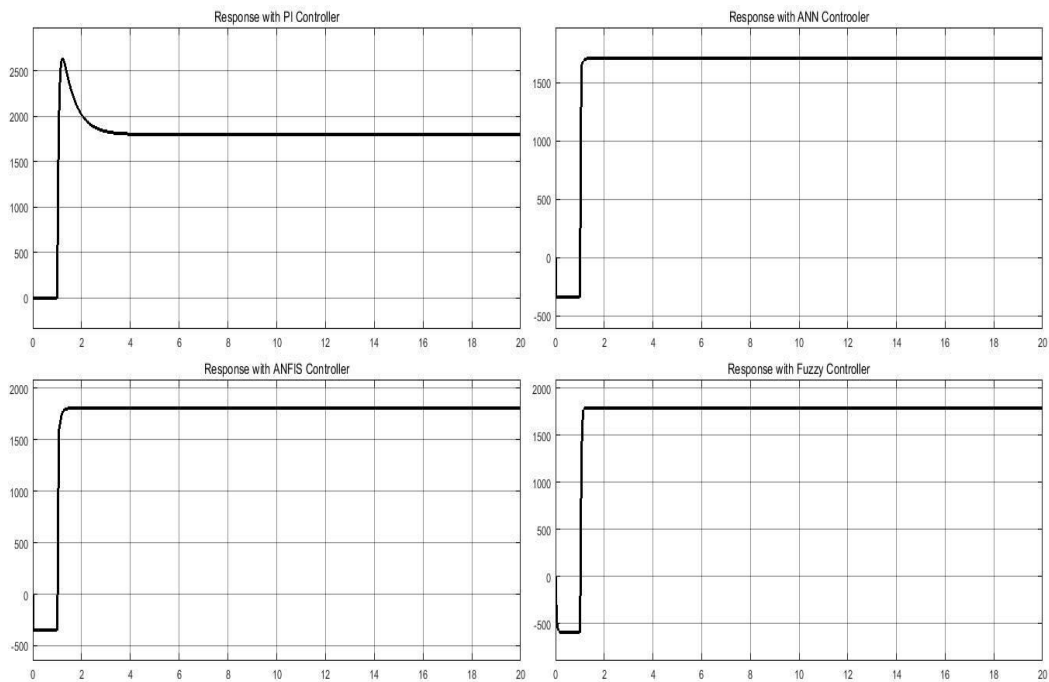

Fig 15.0: Transient Response of the Controllers at 1800 rpm (At rated speed)

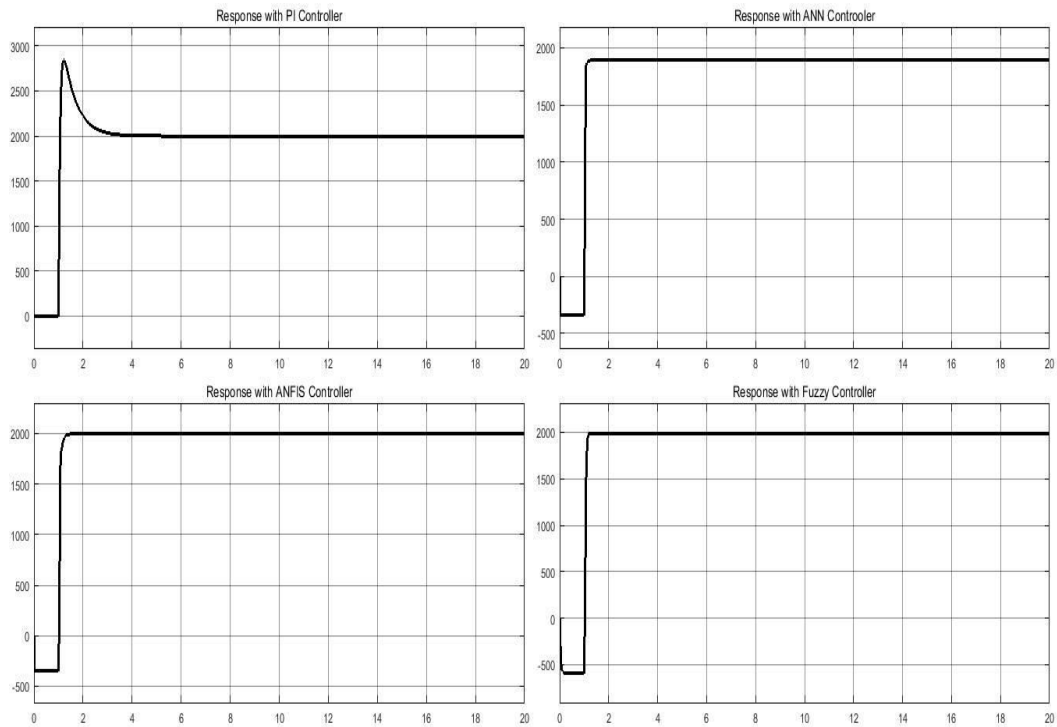

Fig 16.0: Transient Response of the Controllers at 2000 rpm (Above rated speed)

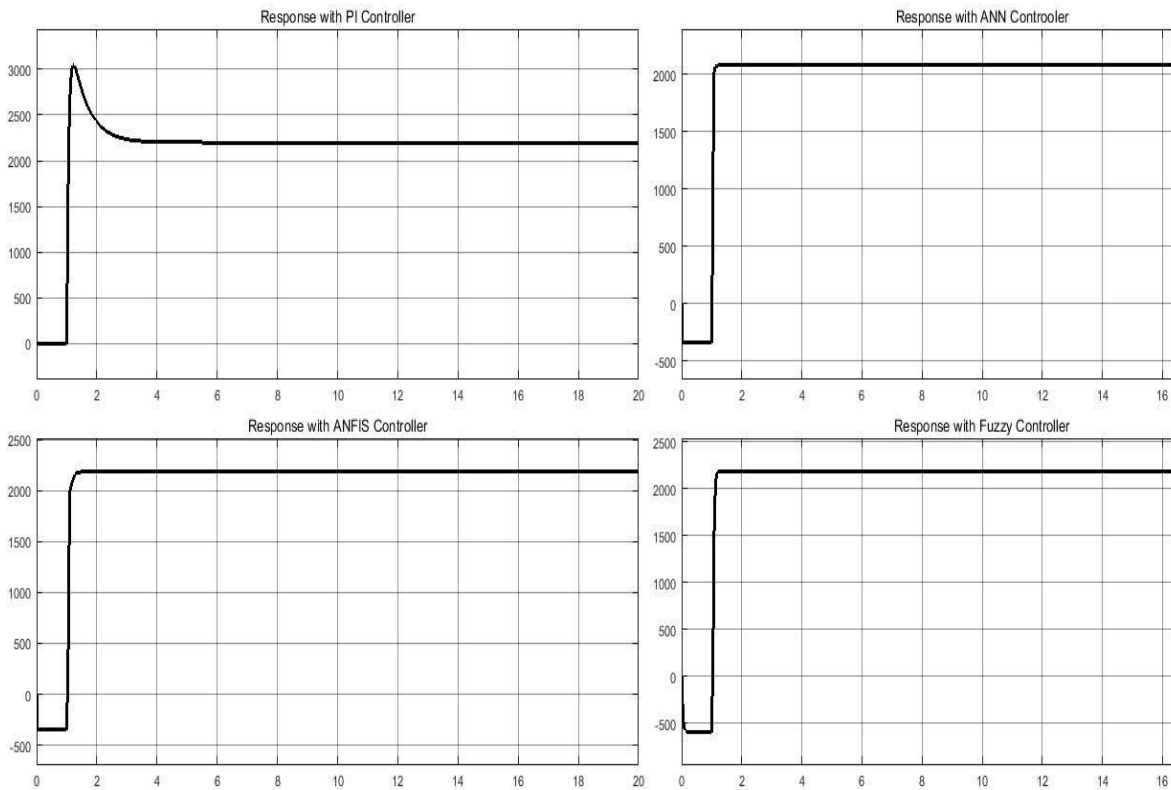

Fig 17.0: Transient Response of the Controllers at 2200 rpm (Above rated speed)



The performance indices for each controller at various speed were summarize below;

Table 3: Performance Index at 1600 rpm (Below Rated Speed)

Controllers Type	% Over Shoot (%)	% Under Shoot (%)	Settling Time (sec)	Steady State Value (rpm)
PI	51	0	5.321	1600
FLC	0	37	1.185	1587
ANN	0	22	1.506	1521
ANFIS	0	21	1.466	1616

From Table 3, it is obvious that ANFIS controller has better transient behavior (having the lowest percentage overshoot and settling time) compared to other controllers while the PI controller demonstrated an excellent steady state accuracy but has the worst transient behavior having the highest overshoot and settling time. The ANN controller was the second best in terms of transient behavior controller followed by the FLC. In terms of steady state accuracy, the PI controller follows the step reference input to higher degree of accuracy followed by the ANFIS controller, then the FLC and finally the ANN.

Table 4: Performance Index at 1800 rpm (At Rated Speed)

Controllers Type	% Over Shoot (%)	% Under Shoot (%)	Settling Time (sec)	Steady State Value (rpm)
PI	47	0	5.281	1800
FLC	0	33	1.185	1785
ANN	0	20	1.669	1706
ANFIS	0	19	1.345	1800

In Table 4, the ANFIS controller gives the lowestpercentage overshoot while the FLC performs better as regardsto the settling time. In terms of steady state accuracy, the PI controller and the ANFIS controller demonstrated the highest level of accuracy in following the reference command followed by the FLC and lastly ANN.

Table 5: Performance Index at 2000 rpm (Above Rated Speed)

Controllers Type	% Over Shoot (%)	% Under Shoot (%)	Settling Time (sec)	Steady State Value (rpm)
PI	41	0	5.281	2000
FLC	0	30	1.225	1982
ANN	0	19	1.506	1893
ANFIS	0	17	1.546	1994

In Table 5, again the ANFIS controller gives the lowestpercentage overshoot whereas the FLC performs better in its settling time. With respect to the steady state accuracy in tracking the reference command signal, the PI controller has the excellent steady state accuracy followed by ANFIS, then ANN and lastlythe FLC.

Table 6: Performance Index at 2200 rpm (Above Rated Speed)

Controllers Type	% Over Shoot (%)	% Under Shoot (%)	Settling Time (sec)	Steady State Value (rpm)
PI	38	0	5.28	2200
FLC	0	27	1.345	2180
ANN	0	22	1.345	2081
ANFIS	0	16	1.426	2180

In Table 6, the ANFIS controller gives the lowestpercentage overshoot while the FLC and the ANN performed best in terms of their settling time. with regards to how accurately the controllers respond in following the reference command



signal, the PI controller has the excellent steady state accuracy followed by ANN while ANFIS and FLC has the least performance.

The average performance index of these controllers is shown in Table 7

Table 7: Controllers Average Performance Indices

Controllers Type	Av. % Over Shoot (%)	Av. % Under Shoot (%)	Av. Settling Time (sec)	Steady State Error (%)
PI	44.25	0	5.290	0
FLC	0	31.71	1.235	6.94
ANN	0	20.75	1.5065	5.26
ANFIS	0	18.25	1.446	0.10

Based on the average performance indices of the controllers shown in Table 7, it will be evident that the ANFIS controller has the overall best desirable performance indices in its transient behavior and steady state accuracy which could be attributed to itsoutmost ability to combine the computational capabilities of the Artificial Neural Network (ANN) to learn from the desired plant performance and its ability to reason as in Fuzzy controller into a single hybrid intelligent unit.

Input	Output	Input	Output	Input	Output	Input	Output	Input	Output
0	0	0.247429	-960.222	-0.0331	-960.02	-0.0202	-960.01	-0.0157	-960.01
0	0	0.291098	-960.14	-0.0146	-960.00	-0.0156	-960.01	-0.0225	-960.01
0	0	0.272208	-960.09	-0.0220	-960.01	-0.0397	-960.02	-0.0704	-960.04
0	0	0.227733	-960.06	-0.0752	-960.04	-0.1129	-960.07	-0.1215	-960.07
1800	1216.781	0.280149	-959.98	-0.0344	-960.02	-0.0985	-960.06	-0.0597	-960.03
1800	1216.781	0.301795	-959.92	-0.0157	-960.01	-0.0331	-960.02	-0.0202	-960.01
1704.713	1219.6	0.278325	-959.89	-0.0225	-960.01	-0.0146	-960.00	-0.0156	-960.01
1598.454	1201.747	0.212081	-959.89	-0.070	-960.04	-0.0220	-960.01	-0.0397	-960.02
1450.885	1164.98	0.092124	-959.92	-0.1215	-960.07	-0.0752	-960.04	-0.1129	-960.07
1274.06	1110.859	0.067827	-959.91	-0.0597	-960.03	-0.0344	-960.02	-0.0985	-960.06
1066.491	1037.081	0.098333	-959.87	-0.0202	-960.01	-0.0157	-960.01	-0.0331	-960.02
824.1289	938.2224	0.082014	-959.87	-0.0156	-960.01	-0.0225	-960.01	-0.0146	-960.00
538.61	803.6798	0.035187	-959.89	-0.0397	-960.02	-0.0704	-960.04	-0.0220	-960.01
199.4207	615.379	-0.05704	-959.94	-0.1129	-960.07	-0.1215	-960.07	-0.0752	-960.04
-198.353	345.6209	-0.03879	-959.93	-0.0985	-960.06	-0.0597	-960.03	-0.0344	-960.02

Table 8: ANN and ANFIS Training Data

REFERENCES

- [1] M. R. Dastranj, E. Ebrahimi, and N. Changizi, "Control DC Motorspeed with Adaptive Neuro-Fuzzy control (ANFIS)," vol. 5, no. 10, pp. 1499–1504, 2011.
- [2] A. Jilani, S. Murawwat, and S. O. Jilani, "Controlling Speed of DC Motor with Fuzzy Controller in Comparison with ANFIS Controller," no. February, pp. 64–74, 2015.
- [3] S. Chapman, *Electrical Machinery Fundamentals*, Fourth. McGraw- Hill, 2005.
- [4] T. Kavya, M. S. Kumar, and C. Dist, "ISSN NO : 2236-6124 Speed Control of DC Motor Using ANFIS Controller Page No : 679 ISSN NO : 2236-6124 Page No : 680," vol. 7, no. 2236, pp. 679–685, 2018.
- [5] A. K. Rajagiri, S. R. Mn, S. S. Nawaz, and S. K. T, "Speed Control of DC Motor using Fuzzy Logic Controller by PCI 6221 with MATLAB," vol. 4, no. 201 9, pp. 1–6, 2019.



- [6] N. L. Ismail, K. A. Zakaria, N. S. M. Nazar, and M. Syaripuddin, “DC motor speed control using fuzzy logic controller DC Motor Speed Control using Fuzzy Logic Controller,” vol. 020026, no. February, 2018.
- [7] A. Shabbir and S. Umesh, “Speed Control of DC Motor using ANFIS Controller,” vol. 8, no. 1, pp. 93–99, 2020.
- [8] P. Tripura, S. Kishore, and B. Yadlapati, “Intelligence Speed Control of DC motor using ANFIS,” no. January 2014, 2016, doi: 10.3233/IFS-120729.
- [9] S. K. Valluru, M. Singh, and N. Kumar, “Implementation of NARMA-L2 Neuro controller for Speed Regulation of Series Connected DC Motor,” no. February 2017, 2012, doi: 10.1109/IICPE.2012.6450518.
- [10] M. Alhanjouri, “Speed Control of DC Motor Using Artificial Neural Network,” no. November, 2017, doi: 10.21275/ART20172035.
- [11] M. J. Deshi, E. C. Anene, and E. E. Omizegba, “Armature Regulation of DC Motor Using PI Controlled DC-DC Flyback Converter,” vol. 5, no. 3, pp. 145–152, 2021.
- [12] A. A. Sadiq, G. A. Bakare, and E. C. Anene, “A Fuzzy-Based Speed Control of DC Motor Using Combined Armature Voltage and Field Current,” no. September, 2013, doi: 10.3182/20130902-3-CN-3020.00146.

BIOGRAPHY



Deshi Maurice Jude (ogak2018@gmail.com): obtained his Bachelor’s degree (B.Eng.) in Electrical and Electronics Engineering and a Master’s degree (M.Eng.) in Electrical Engineering (Electronics) at Abubakar Tafawa Balewa University Bauchi. He is the Author of Fundamentals of Science and Engineering Mathematics and also the Author of Advance Mathematics for Science and Engineering. His research interest is in control systems engineering and power electronics and industrial drives



Usman Isa Hassan(isausman72@gmail.com): obtained his B.Eng. (Electrical/Electronic Engineering) in 1998, M.Eng. (Electronics) in 2011 and currently PhD student at Abubakar Tafawa Balewa University Bauchi. He has worked as Senior Telecommunication Engineer in the defunct NITEL/MTEL from 2001 to 2010 and also as Chief Maintenance Engineer in Zaki (Cowrie) Flour Mill from 2010 to 2012. He is currently a Senior Lecturer in the department of Electrical/Electronic Engineering at the Federal Polytechnic Bauchi.



Mahdi Hamza Abdullahi (hamzaam@fptb.edu.ng): obtained his National Diploma (ND) and Higher National Diploma (HND) in Electrical and Electronics Engineering at Federal Polytechnic Bauchi. He also bagged his Postgraduate Diploma in Electrical and Electronics Engineering at Abubakar Tafawa Balewa University Bauchi and he is currently a master student with the Abubakar Tafawa Balewa University Bauchi and also lecturer with the Federal Polytechnic Bauchi.



Moses Bako(jilongmoses@gmail.com): obtained his National Diploma (ND) in Science Laboratory Technology with Plateau State Polytechnic Barkin Ladi and a Higher National Diploma (HND) in Physics with Electronics from Federal Polytechnic Bauchi. He also bagged his Postgraduate Diploma in Electrical and Electronics Engineering at Abubakar Tafawa Balewa University Bauchi and he is currently a master student with the Abubakar Tafawa Balewa University Bauchi and an instructor with Plateau State Polytechnic Barkin Ladi.



Umar Aminu (uaminu.mtet@fptb.edu.ng): Obtained his bachelor’s degree (B.Eng.) in Electrical and Electronics Engineering at Ahmadu Bello University Zaria. He has worked as electrical engineer II in the ministry of power, science and technology, Bauchi and currently a lecturer in the department of Mechatronics Engineering Federal Polytechnic Bauchi.

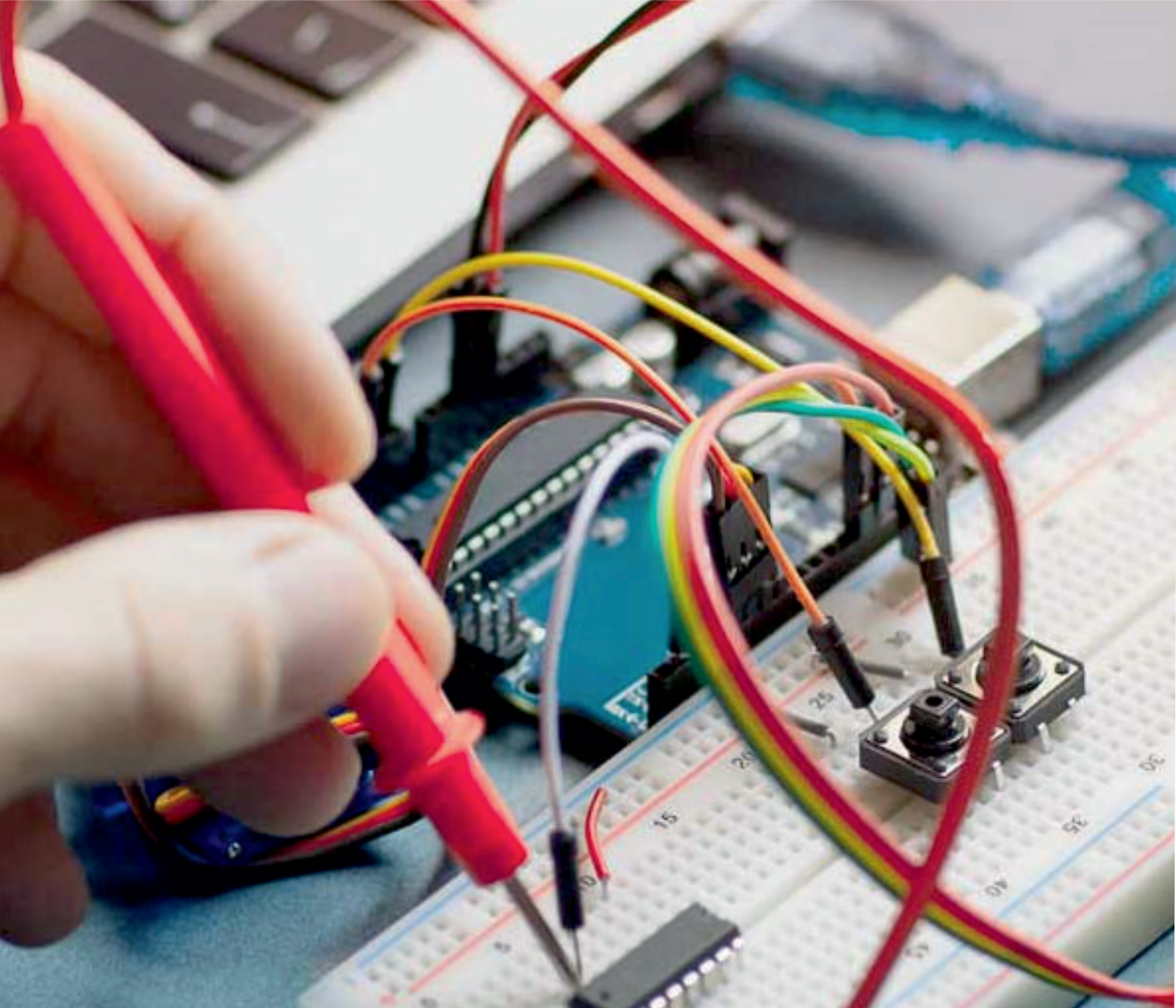

INNO SPACE
SJIF Scientific Journal Impact Factor
Impact Factor: 7.282



ISSN INTERNATIONAL
STANDARD
SERIAL
NUMBER
INDIA



International Journal of Advanced Research

in Electrical, Electronics and Instrumentation Engineering

 **9940 572 462**  **6381 907 438**  **ijareeie@gmail.com**



www.ijareeie.com

Scan to save the contact details