



e-ISSN: 2278-8875

p-ISSN: 2320-3765

International Journal of Advanced Research

in Electrical, Electronics and Instrumentation Engineering

Volume 9, Issue 10, October 2020

ISSN INTERNATIONAL
STANDARD
SERIAL
NUMBER
INDIA

Impact Factor: 7.122

9940 572 462

6381 907 438

ijareeie@gmail.com

www.ijareeie.com



Simulation Model of Maximum Power Extraction Technique for Wind and Hybrid Renewable Energy System

Anand Kumar¹, Prof. Manju Gupta²

M. Tech. Scholar, Department of Electrical & Electronics Engineering, OIST, Bhopal, India

Associate Professor, Department of Electrical & Electronics Engineering, OIST, Bhopal, India

ABSTRACT: The proposed system presents power-control strategies of a grid-connected hybrid generation system with versatile power transfer. This hybrid framework permits most extreme usage of openly accessible sustainable power sources like wind and photovoltaic energies. For this, a versatile MPPT calculation alongside standard annoy and watches technique will be utilized for the framework. Likewise, this design enables the two sources to supply the heap independently or at the same time contingent upon the accessibility of the energy sources. The turbine rotor speed is the fundamental determinant of mechanical yield from wind energy and Solar cell working voltage on account of yield control from solar powered energy. Permanent Magnet Synchronous Generator is combined with twist turbine for accomplishing wind energy transformation framework.

KEYWORDS: Fuel cell, Photovoltaic, Wind energy conversion, Wind Turbines, Z- source converter

I. INTRODUCTION

Recent developments and trends in the electric power consumption indicate an increasing use of renewable energy. Basically all districts of the world have inexhaustible assets of some kind. By these perspective investigations on sustainable power sources concentrates increasingly consideration. Solar energy and wind energy are the two sustainable power sources most basic being used. Wind energy has turned into the minimum costly sustainable power source innovation in presence and has topped the enthusiasm of researchers and teachers over the world [1]. Photovoltaic cells change over the energy from daylight into DC power. PVs offer included favorable circumstances over other sustainable power sources in that they radiate no commotion and require for all intents and purposes no upkeep [2]. Hybridizing solar and wind control sources give a practical type of energy age.

Numerous investigations have been done on the utilization of sustainable power hotspots for control age and numerous papers were exhibited before. The wind and solar powered energy frameworks are exceptionally inconsistent because of their unusual nature. In [3], a PV board was joined with a diesel electric power framework to dissect the lessening in the fuel expended. It was seen that the fuse of an extra inexhaustible source can additionally lessen the fuel utilization. A few crossover wind/PV control frameworks with Maximum Power Point Tracking (MPPT) control have been proposed before [4]. They utilized a different DC/DC buck and buck-help converter associated in combination in the rectifier stage to play out the MPPT control for every one of the sustainable power source control sources. These frameworks have issues that, because of the ecological components impacting the wind turbine generator, high recurrence current music are infused. Buck and buck-support converters don't have the ability to dispense with these sounds. So the framework requires inactive information channels to expel it, making the framework more massive and costly [5]. In this paper, another converter topology for hybridizing the wind and solar light based energy sources has been proposed. The Cuk-SEPIC combined converters have the capacity to dispense with the HF current sounds in the wind generator. This takes out the need of aloof information channels in the framework. These converters can bolster advance up and venture down tasks for each sustainable power sources. They can likewise bolster individual and concurrent tasks. Solar energy source is the contribution to the Cuk converter and wind energy source is the contribution to the SEPIC converter [6, 7]. The normal yield voltage created by the framework will be the whole of the contributions of these two frameworks. Every one of these points of interest of the proposed half and half framework makes it exceedingly proficient and solid.

II. MPPT ALGORITHM

Because of the lesser efficiency of photovoltaic array most of the energy, impacting over array gets wasted. The calculation known is most extreme power point following might be useful to improve the execution of solar board [8].



The MPPT calculation is deals with key of Thevenin, agreeing which the power yield of a circuit is most extreme when impedance of circuit matches with the heap of impedance. So now we need to coordinate the impedance as opposed to following greatest power point.

There are different techniques used to track the maximum power point. Few of the most popular techniques are:

- Perturb and observe (hill climbing method)
- Incremental Conductance method
- Fractional short circuit current
- Fractional open circuit voltage

Perturb and observe

The P&O algorithm furthermore, "slope climbing", the two names allude to a similar calculation relying upon how it is executed. The fundamental distinction between these two is that Hill-climbing includes a deviation of the obligation cycle of the power converter and in P&O nervousness on the working voltage of the DC connect between the PV exhibit and the power converter happens [9]. The deviation of obligation cycle of the power converter is the adjustment of the voltage of DC connects between the PV exhibit and the power converter alludes as Hill-climbing, so the two names allude to a similar system. What ought to be the following irritation is chosen by thinking about the indication of the last annoyance and the indication of the last addition in the power.

The irritation will stay a similar way if control is augmented, and if control is diminished then next annoyance will be the other way. The procedure will be rehashed until the point when the purpose of most extreme power will be come to. At that point the working point sways around the MPP [10].

Incremental conductance

The slope of the curve between power and voltage of PV module is the deciding factor in incremental conductance algorithm, if it is zero it shows point of MPP positive (negative) on the left of it and negative (positive) on the right.

- $\Delta V/\Delta P = 0$ at the MPP
- $\Delta V/\Delta P > 0$ on the left
- $\Delta V/\Delta P < 0$ on the right

The change of MPP voltage is identified by comparing the change of the power to increment of the voltage of current curve.

Fractional short circuit current

Fractional short circuit current method states that the ratio between array voltages at maximum power V_{MPP} to its open circuit voltage V_{OC} is nearly constant.

$$V_{MPP} \approx k_1 V_{OC}$$

The constant K_1 is having value between 0.71 to 0.78. Now the value of V_{MPP} can be calculate by periodically measuring V_{OC} . This method is simple and cheap to implement but its efficiency is relatively low due to the utilization of inaccurate values of the constant k_1 in the computation of V_{MPP} [11].

Photovoltaic cell

To convert the light energy supplied by solar the semiconductor arrangement is the photovoltaic cell it changes over light energy to electrical energy by photovoltaic impact. The energy photons are accessible with light, if there energy is more noteworthy than the energy hole of nuclear hardware, than the external most electrons of particles are get produced as a result of the effect of these photon. These electrons get stream uninhibitedly and cause current [12].

The development of photovoltaic cell is comparative as the development of p-n intersection diode. A photovoltaic cell is made out of two distinct layers of silicon one is P-type layer where negative particles are there with one less valence electron and other is N-type layer with positive particles with one additional valence electron. At the intersection of these two layers additional electrons of N-layers get diffused with less electron space of P – layer and leave area with positive and negative particles as it were. This space is known as dissemination layer, the dispersion layer go about as a defensive layer and stops the exchange of electron over the intersection when balance is come to. At the point when solar energy is forced the energy of electrons accessible will increment and again exchange of electron get begin. This will cause stream of current and change over solar powered energy into electric energy.



MATLAB Modelling -

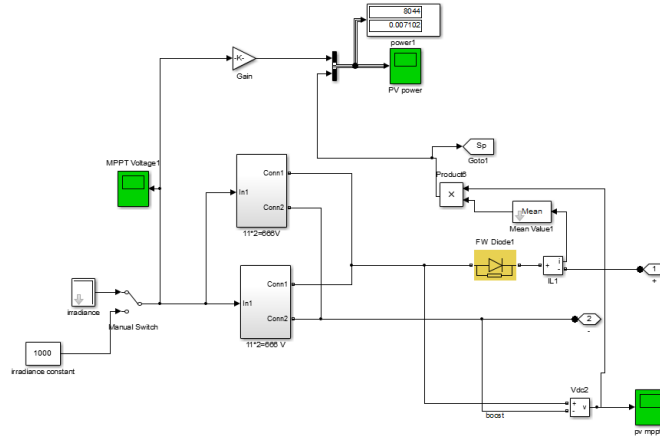

Figure 1: MATLAB Model for PV System

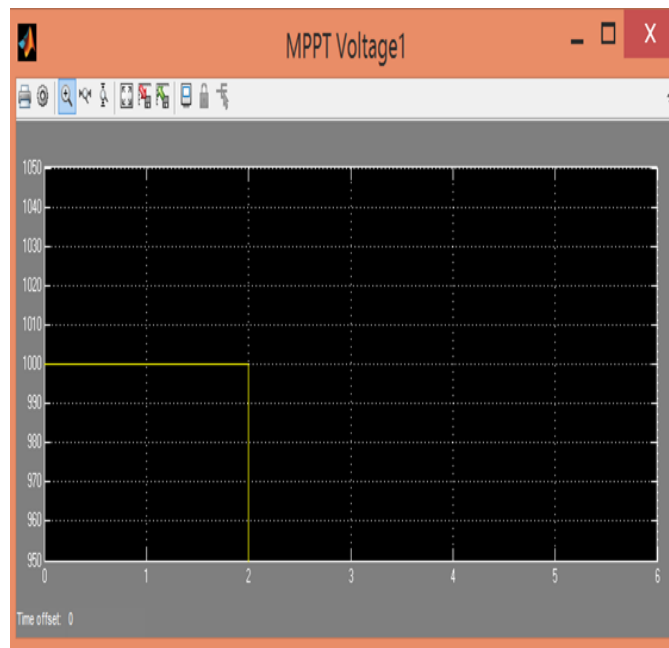

Figure 2: Output Voltage of Maximum Power Point Tracking

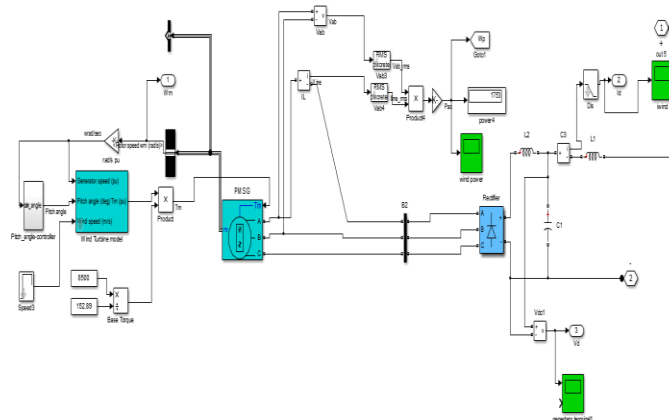

Figure 3: MATLAB Model for Wind System

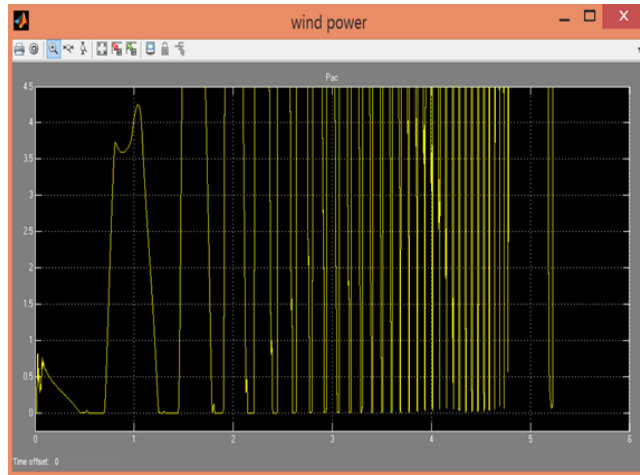

Figure 4: Output Voltage of Wind Power

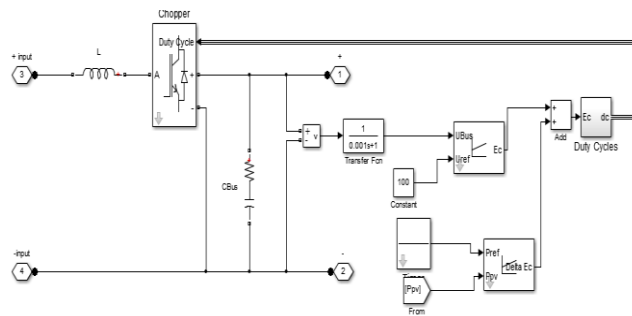

Figure 5: MATLAB Model for DC-DC Converter

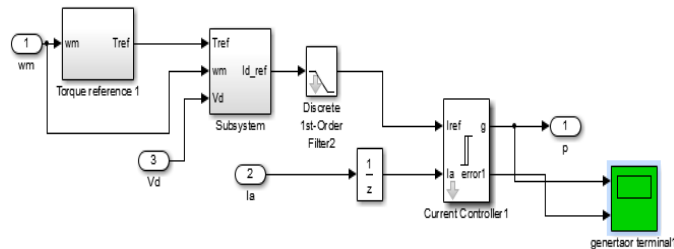

Figure 6: MATLAB Model for wind MPPT

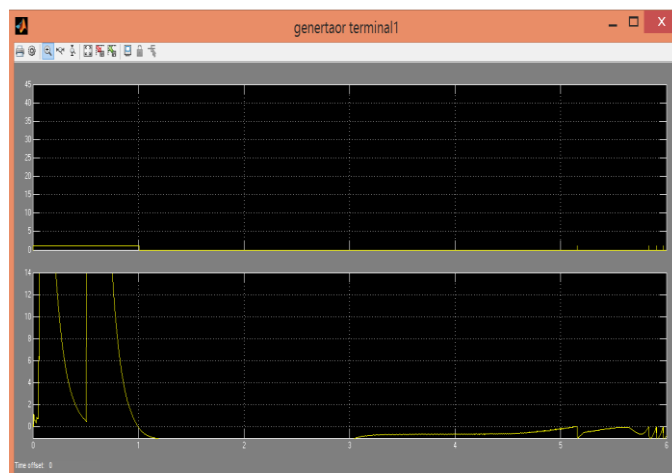

Figure 7: Generator Voltage of wind MPPT

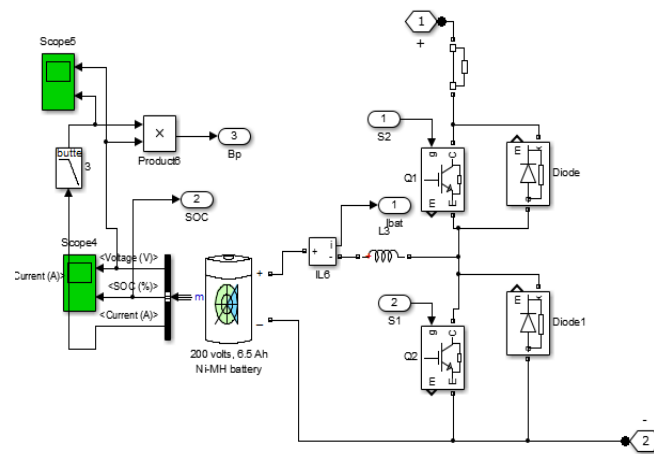

Figure 8: MATLAB Model for Battery and DC-DC Converter

III. SIMULATION MODEL

The proposed system presents control techniques of a lattice associated cross breed age framework with adaptable power exchange. This half and half framework permits most extreme usage of uninhibitedly accessible sustainable power sources like wind and photovoltaic energies. For this, a versatile MPPT calculation alongside standard annoy and watches strategy will be utilized for the framework. Additionally, this arrangement enables the two sources to supply the heap independently or at the same time contingent upon the accessibility of the energy sources. The turbine rotor speed is the primary determinant of mechanical yield from wind energy and Solar cell working voltage on account of yield control from solar based energy. Lasting Magnet Synchronous Generator is combined with twist turbine for accomplishing wind energy change framework.

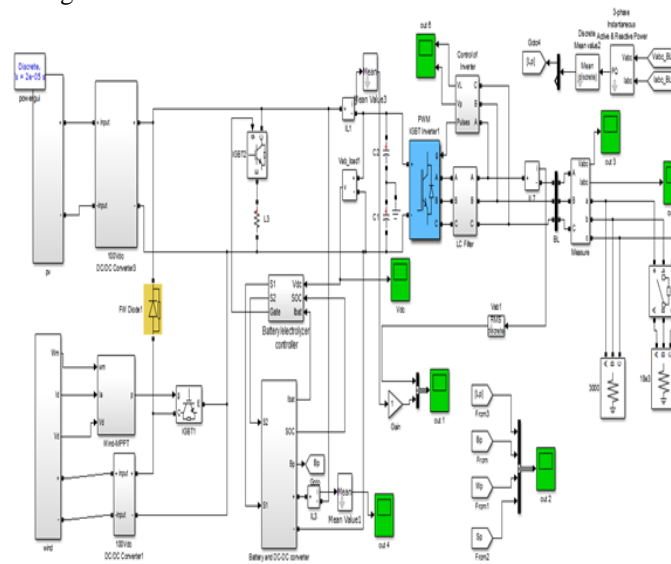

Figure 9: MATLAB Simulink Model of Hybrid Wind-Solar Energy System using MPPT Algorithm

The inverter converts the DC output from non-conventional energy into useful AC power for the connected load. This mixture framework works under typical conditions which incorporate ordinary room temperature on account of solar powered energy and ordinary wind speed at plain territory on account of wind energy. The recreation comes about are displayed to outline the working standard, plausibility and unwavering quality of this proposed framework.

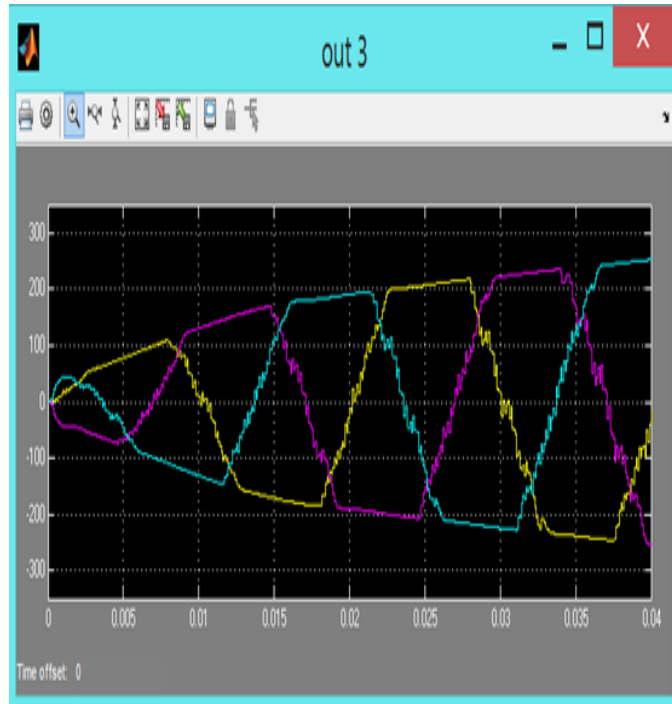

Figure 10: Output Voltage of wind and solar energy hybrid system

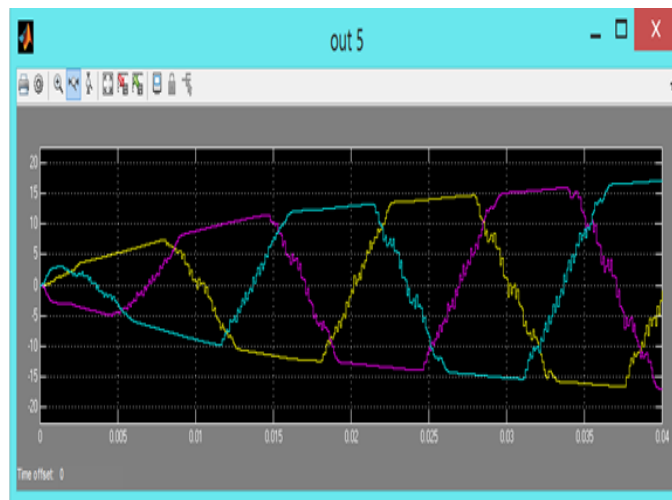

Figure 11: Output Current of wind and solar energy hybrid system

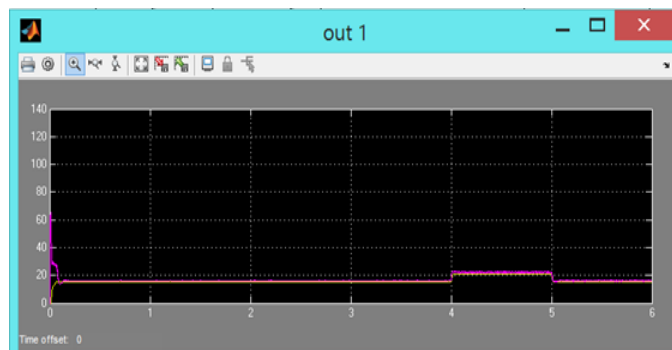

Figure 12: Gain of wind and solar energy hybrid system



IV. Conclusion

Renewable energy sources also called non-conventional type of energy are continuously replenished by natural processes. Hybrid systems are the correct answer for a spotless energy generation. Hybridizing solar light based and wind control sources give a practical type of energy age. Here, a cross breed wind and solar light based energy framework with a converter topology is proposed which makes utilization of Cuk and SEPIC converters in the outline. This converter configuration defeats the disadvantages of the prior proposed converters. This topology enables the two sources to supply the heap independently or all the while relying upon the accessibility of the energy sources. MPPT control is improved the situation PV and wind energy with the goal that greatest power is followed and framework work all the more dependably and effectively. This framework has bring down working expense and discovers applications in remote territory control age, consistent speed and variable speed energy change frameworks and country jolt. MATLAB/SIMULINK programming is utilized to demonstrate the PV board, wind turbine, DC-DC converters, MPPT controller and proposed crossover framework.

REFERENCES

- [1] Joanne Hui, Alireza Bakhshai, and Praveen K. Jain, "A Hybrid Wind-Solar Energy System: A New Rectifier Stage Topology," IEEE Conference, February 2010.
- [2] Trishan Eram, and Patrick L. Chapman, "Comparison of Photovoltaic Array Maximum Power Point Tracking Technique," IEEE Trans. on energy conversion, vol. 22, no. 2, June 2007.
- [3] [Cody A. Hill, Matthew Clayton Such, Dongmei Chen, Juan Gonzalez, and W.Mack Grady, "Battery Energy Storage for Enabling Integration of Distributed Solar Power Generation," IEEE Transactions on smart grid, vol. 3, no. 2, June 2012.
- [4] Hao Qian, Jianhui Zhang and Jih-Sheng Lai, "a grid-tie battery energy storage system," IEEE Conference, June 2010.
- [5] Sharad W. Mohod, and Mohan V. Aware, "Micro Wind Power Generator With Battery Energy Storage For Critical Load," IEEE systems journal, vol. 6, no. 1, march 2012
- [6] S.K. Kim, J.H Jeon, C.H. Cho, J.B. Ahn, and S.H. Kwon, "Dynamic Modeling and Control of a Grid-Connected Hybrid Generation System with Versatile Power Transfer," IEEE Transactions on Industrial Electronics, vol. 55, pp. 1677-1688, April 2008.
- [7] Nabil A, Ahmed and Masafumi Miyatake, "A Stand – Alone Hybrid Generation System Combining Solar Photovoltaic and Wind Turbine with Simple Maximum Power Point Tracking Control," IEEE Conference, August 2006.
- [8] S. Jain, and V. Agarwal, "An Integrated Hybrid Power Supply for Distributed Generation Applications Fed by Nonconventional Energy Sources," IEEE Transactions on Energy Conversion, vol. 23, June 2008.
- [9] Matthew Clayton Such, Cody Hill, "Battery Energy Storage and Wind Energy Integrated into the Smart Grid," IEEE Conference, January 2012.
- [10] Hao Qian, Jianhui Zhang, Jih-Sheng (Jason) Lai, Wensong Yu, "A High-Efficiency Grid-Tie Battery Energy Storage System," IEEE transactions on power electronics, vol. 26, no. 3, march 2011
- [11] Niraj Garimella and Nirmal-Kumar C. Nair, "Assessment of Battery Energy Storage Systems for Small-Scale Renewable Energy Integration," IEEE Conference, January 2009.
- [12] Dezso Sera, Tamas Kerekes, Remus Teodorescu and Frede Blaabjerg, "Improved MPPT Algorithms for Rapidly Changing Environmental Conditions," IEEE Conference, September 2006.

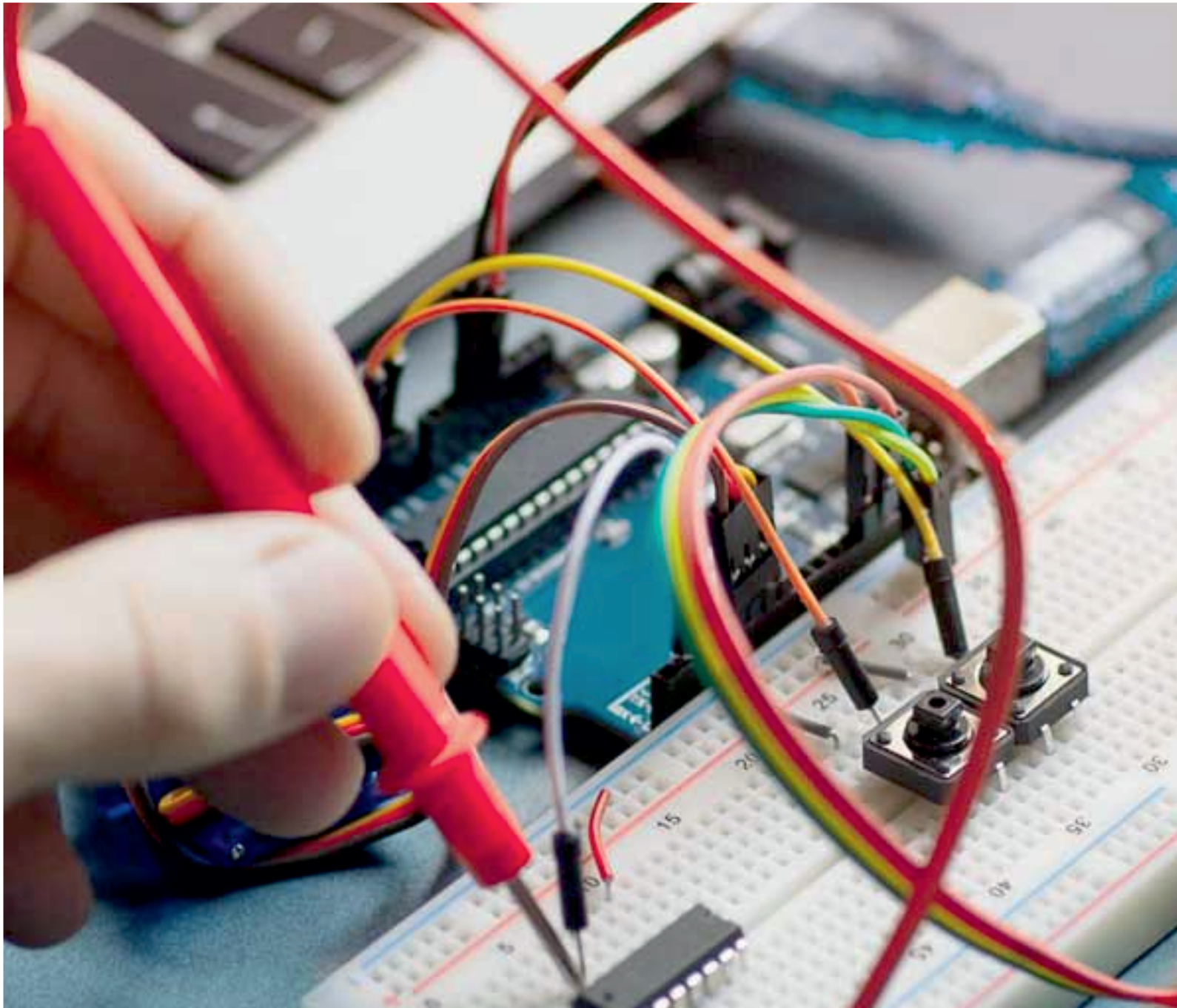

INNO  **SPACE**
SJIF Scientific Journal Impact Factor

Impact Factor:
7.122

ISSN INTERNATIONAL
STANDARD
SERIAL
NUMBER
INDIA



International Journal of Advanced Research

in Electrical, Electronics and Instrumentation Engineering

 **9940 572 462**  **6381 907 438**  **ijareeie@gmail.com**



www.ijareeie.com

Scan to save the contact details