

e-ISSN: 2278-8875

p-ISSN: 2320-3765

International Journal of Advanced Research

in Electrical, Electronics and Instrumentation Engineering

Volume 9, Issue 10, October 2020

ISSN INTERNATIONAL
STANDARD
SERIAL
NUMBER
INDIA

Impact Factor: 7.122

9940 572 462

6381 907 438

ijareeie@gmail.com

www.ijareeie.com



Soft Starter for Three Phase Induction Motor by Implementation of IGBT based Inverter Circuit

Shital Shelke¹, Prof. S.D. Jawale²

M.E Student , Department of Electrical Engineering Jawaharlal Nehru Engineering College - [JNEC], BAMU.

Aurangabad, India¹

Professor, Department of Electrical Engineering, Jawaharlal Nehru Engineering College - [JNEC], BAMU.

Aurangabad, India²

ABSTRACT: Starter for three-phase induction motor which is taking very large currents during starting period from a 3-phase supply and our constructed Matlab simulation of soft starter along with their results .We have constructed hardware of project as well simulate component rating in Matlab Simulink and calculated result were added in this paper . To exclusion the adverse effects of unnecessary high value starting torque and high inrush currents in induction motor, Soft-starters are used for avoiding this problem and to achieve smooth starting of large capacity induction motors increases the life and reliability of belts, gear boxes, chain drives, motor bearings, and shafts also avoid the eliminating voltage dip and brown out conditions. Soft starter are used IGBTs switches to giving proper gate pluses and the zero crossing is used to know where exactly the input voltage is crossing the zero point, As per the zero crossing position of the input voltage the particular switch of the starter circuit is turned on. To control this circuit gives the required gate pulses for the inverter switches by PIC 18F442 microcontroller is used. Soft starters are usefully induction motor controllers in compressors, blowers, fans, pumps, mixers, crushers and grinders, and many other applications.

KEYWORDS:converter, rectifier, IGBT (insulated gate bipolar transistor) , PIC peripheral interface controller

I.INTRODUCTION

Having Squirrel Cage type rotor ,that Induction Motor is usually used in industrial purpose applications because of their simplicity of structure, economical matter, reliability & relatively better efficiency. This motor having high starting or initial current so for avoid this problem a solution is soft starter. Soft starter is gives the smooth acceleration, which reduces tension exerted on drive system consist mechanical component having high value of starting or initial torque, hence improves the life & reliability of belts, gear boxes, chain drives, motor bearings, and shafts also avoid the eliminating voltage dip and brown out conditions. Totally controllable starting torque & speed for required starting performance, provides enough torque to accelerate to load while minimizing both electrical shock &mechanical to the system. Energy conserving & efficient by voltage control is achieved by controlling the applied voltage if load torque specific necessity can be fulfil with less than rated flux. By this method core loss and stator copper losses may be reduced. The soft starter utilize two anti-parallelattached switches in each phase.

II.SYSTEM DEVELOPMNT OF PROPSED SYSTEM HARDWARE ARCHITECHTURE

A. Working of constructed hardware

Standard 3 phase AC supply is converted to a DC voltage by using a 3-phase diode bridge rectifier. A capacitor filters the ripple in the DC bus. This DC bus is used to generate a variable voltage and variable frequency power supply. A voltage source power inverter is used to convert the DC bus to the required AC voltage and frequency. In summary, the power section consists of a power rectifier, filter capacitor, and power inverter. The motor is connected to the inverter as shown in Figure 4. The power inverter has 6 switches that are controlled in order to generate an AC output from the DC input. PWM signals generated from the microcontroller control these 6 switches. The phase voltage is determined by the duty cycle of the PWM signals. In time, a maximum of three switches will be on, either one upper and two lower switches, or two upper andone lower switch. When the switches are on, current flows from the DC bus to the motor winding. Because the motor windings are highly inductive in nature, they hold electric energy in the form of current. This current needs to be dissipated while switches are off. Diodes connected across the switches give a path for the current to dissipate when the switches are off. These diodes are also called freewheeling diodes. Upper and lower



switches of the same limb should not be switched on at the same time. This will prevent the DC bus supply from being shorted. A dead time is given between switching off the upper switch and switching on the lower switch and vice versa. This ensures that both switches are not conductive when they change states from on to off, or vice versa. To derive a varying AC voltage from the power inverter, pulse width modulation (PWM) is required to control the duration of the switches' ON and OFF times. Three PWMs are required to control the upper three switches of the power inverter. The lower switches are controlled by the inverted PWM signals of the corresponding upper switch. A dead time is given between switching off the upper switch and switching on the lower switch and vice versa, to avoid shorting the DC bus. The three PWMs are connected to the driver chip (IR21362). These three PWMs switch the upper three switches of the power inverter. The lower switches are controlled by the inverted PWM signals of the corresponding upper switch. The driver chip generates 200 ns of dead time between upper and lower switches of all phases. A potentiometer connected to a 10-bit ADC channel on the PIC microcontroller determines the motor speed. The microcontroller uses the ADC results to calculate the duty cycle of the PWMs and thus, the motor frequency. The ADC is checked every 2.2 milliseconds, which provides smooth frequency transitions.

B. IGBT Based Inverter circuit

IGBT has three terminals attached to three different metal layers, the metal layer of the gate terminal is insulated from the semiconductors by a layer of silicon dioxide (SiO₂). IGBT is constructed with 4 layers of semiconductor sandwiched together. A three-phase based on IGBT inverter is used to alter an input DC to a 3-phase output AC. Generally, its 3-arms are deferred with 120° of an angle to produce a 3-phase AC supply. The inverter control which has a 50% of the ratio as well as controlling can take place after every T/6 of the time T. The switches used in the inverter complement each other.

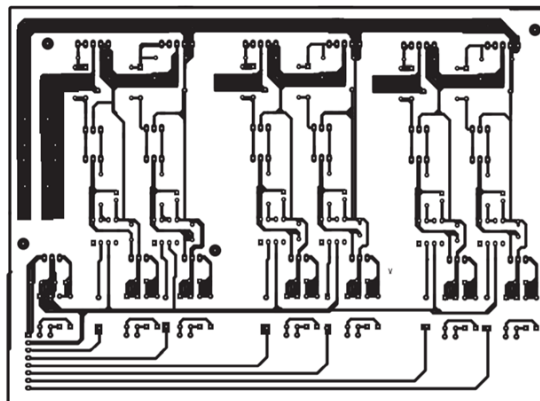

Fig1.PCB Layout of IGBT

C. Positive Voltage Regulators

The L7800 series of three-terminal positive regulators is available in TO-220, TO-220FP, TO-220FM, TO-3 and D2PAK packages and several fixed output voltages, making it useful in a wide range of applications. These regulators can provide local on-card regulation, eliminating the distribution problems associated with single point regulation. Each type employs internal current limiting, thermal shut-down and safe area protection, making it essentially indestructible. If adequate heat sinking is provided, they can deliver over 1A output current. Although designed primarily as fixed voltage regulators, these devices can be used with external components to obtain adjustable voltage and currents.

D. TLP 250 Opto-coupler

An opto-coupler or optoelectronic coupler is an electronic component that basically acts as an interface between the two separate circuits with different voltage levels. Opto-coupler are common component by which electrical isolation can be supplied between the input and output source. It is a 6 pin device and can have any number of photodetectors. Here, a beam of light emitted by a light source exists as an only contact between input and output. Due to this, we can have an insulation resistance of mega ohms between the two circuits. In high voltage applications where the voltage difference between the two circuits differs by several thousand volts, such isolation is favourable. The use of all such electronic isolators lies in all that conditions where the signal is to pass between two isolated circuits.

E. Microcontroller Unit (PIC1Parallel Slave Port Data F452)

Microcontroller Unit having specification of Operating Frequency DC : 4MHz ,Digital I/O : 4 ,Program Memory (Bytes) : 32K, Program Memory (Instructions) : 163Parallel Slave Port Data 4 ,Data Memory (Bytes) : 1536 ,Data EEPROM Memory (Bytes): 256 ,Interrupt Sources : 1Parallel Slave Port Data ,I/O Ports : Ports A, B, C, D, E ,Timers : 4



,Capture/Compare/PWM Modules : 2 ,Serial Communications : MSSP, Addressable USART ,Parallel Communications : PSP ,1Digital I/O.-bit Analog-to-Digital Module : Parallel Slave Port Data input channels ,RESETS (and Delays) : POR, BOR, RESET Instruction, Stack Full, Stack Underflow (PWRT, OST) ,Programmable Low Voltage Detect : Yes ,Instruction Set : Yes ,Packages : 4Digital I/O.-pin DIP 44-pin PLCC 44-pin TQFP

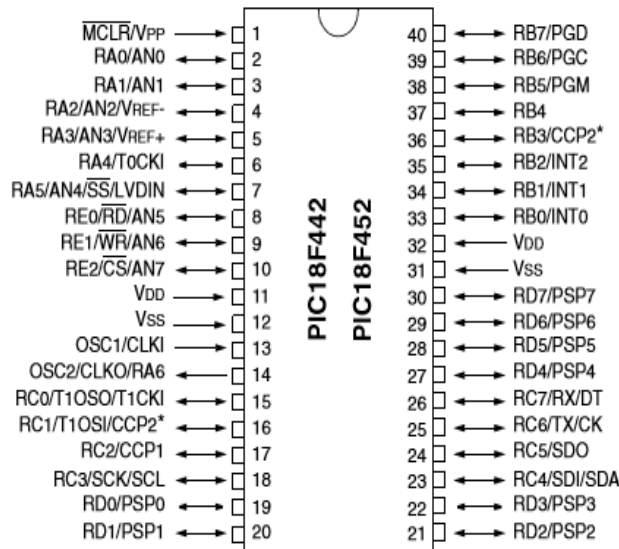

Fig 2. Pin diagram of PIC 18F442

F. Circuit Diagram of Soft Starter Based on IGBT

Below fig shows the circuit diagram of the proposed system, which consist of power supply section, microcontroller section, IGBT Bridge circuit, SMPS circuit etc.

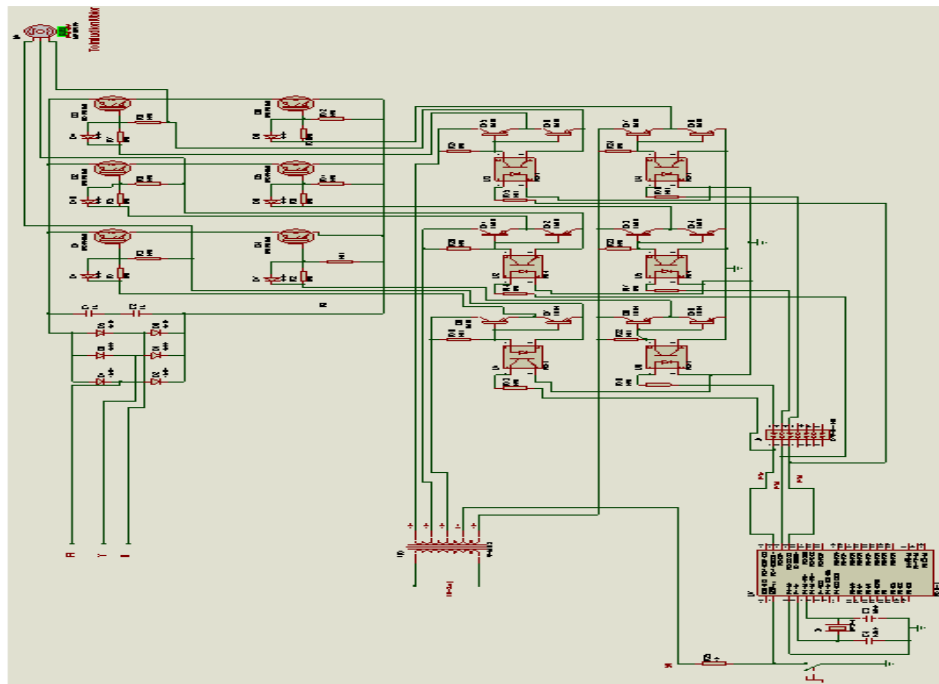

Fig:3 Circuit diagram of soft starter based on IG

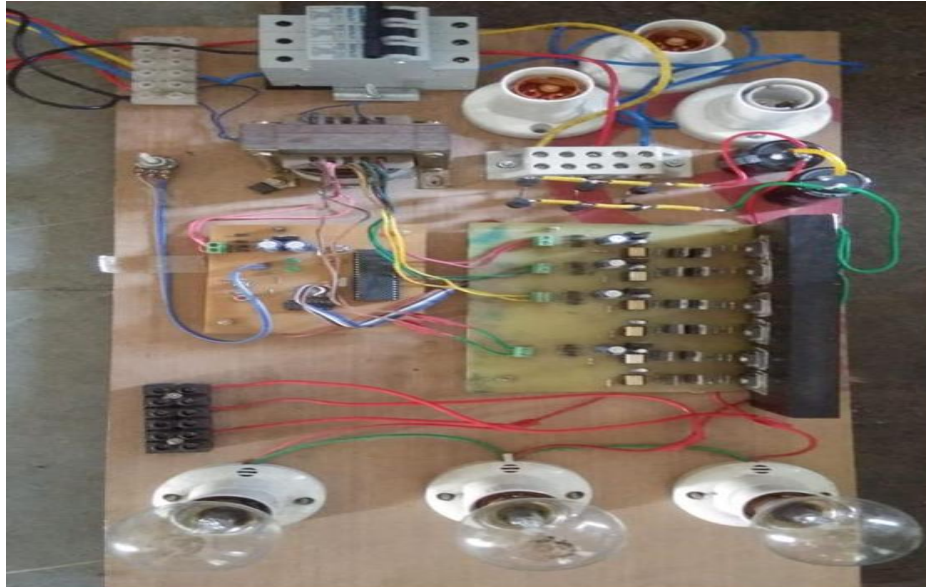

Fig. 4 Constructed Hardware of Project

III. HARDWARE TEST RESULTS

Experimental results and analysis of with and without soft starter. The developed IGBT based soft starter is included in the motor drive system and the starting current and voltage are noted in given table:

Parameter	Soft Starter	DOL Starter	Star-Delta Starter
Current	Reduced by 30% to 50% of its starting current.	6% to 8% greater than of its running current	Reduced to 1/3 rd of its starting current
Torque	Reduced high inrush starting torque	Unnecessary high starting torque	Low Starting Torque

Table 1. Hardware test result

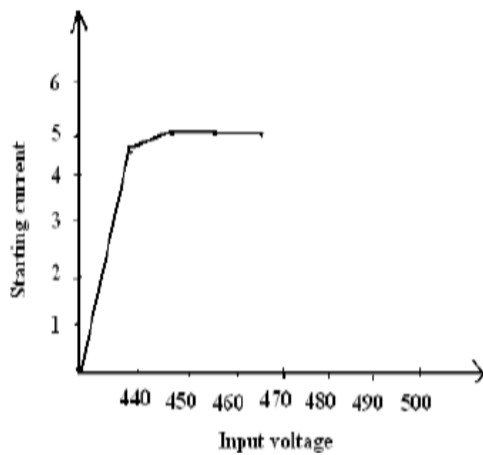

Fig 5. Starting current curve Without Soft Starter

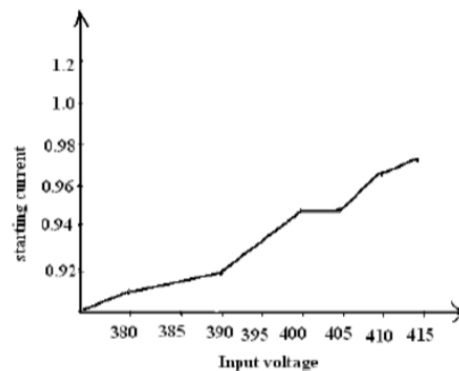

Fig 6. Starting current curve with Soft Starter



By observing Fig. we can say that the starting current of motor without soft starter is 3 to 5% more than the rated current. In this work by including the soft starter the starting current and voltage are reduced to 30% to 50% of the full load current as shown in above fig. In this paper by controlling the gate voltage we can give the controlled voltage at motor input so that the starting current can be reduced substantially.

IV. MATLAB SIMULATION AND SIMULINK OUTPUT

The induction motor is fed by a current-controlled PWM inverter which is built using a Universal Bridge block. The IGBT turns on when the collector-emitter voltage is positive and greater than V_f and a positive signal is applied at the gate input ($g > \text{Digital I/O.}$). It turns off when the collector-emitter voltage is positive and a Digital I/O. signal is applied at the gate input ($g = \text{Digital I/O.}$). PWM is connected with IGBT drive. Use pulse-width modulation (PWM) to change the duty-cycle of square-wave pulses output by a PWM pin on the microcontroller hardware. PWM enables a digital output to provide a range of different power levels, similar to that of an analogue output. A constant voltage positive input signal across the gate and emitter terminals will maintain the device in active state. To operate these switches the gate pulses should be given to the motor. And also provide limited current.

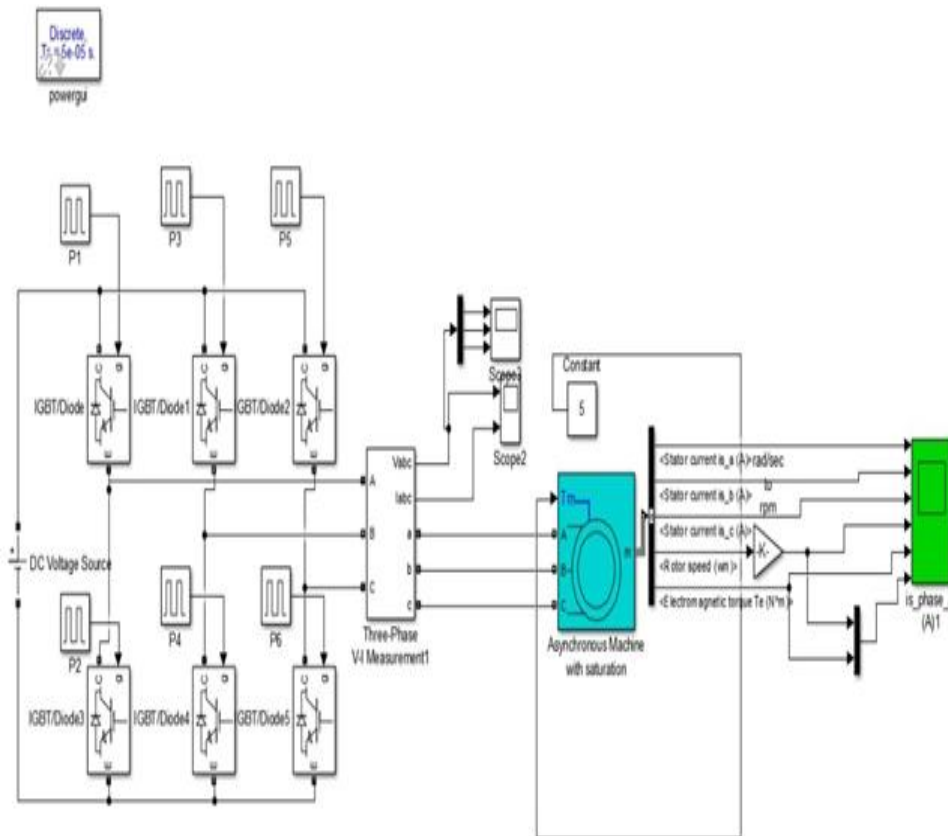

Fig.7 Simulation Model of Soft Starter based on IGBT

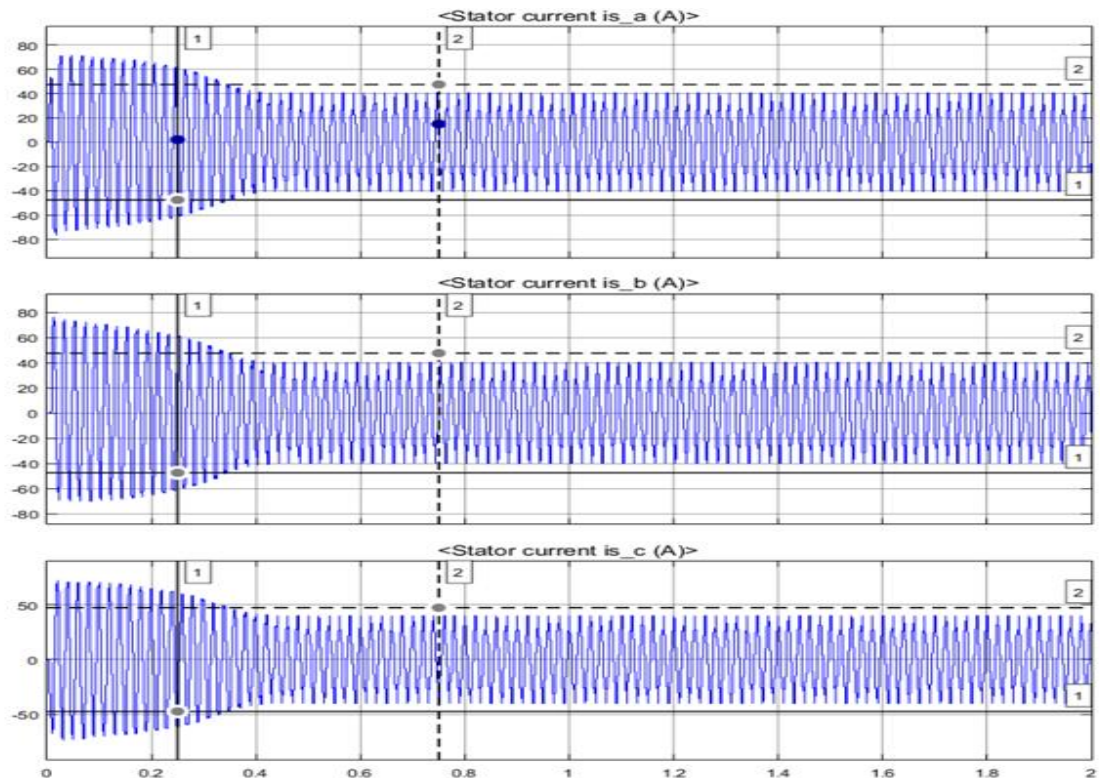

Fig: 8 Stator current versus time characteristics

V. CONCLUSION

.Soft Starter give's validity and flexibility better than other different types of conventional starting techniques. From the study it is seen that the starting current in soft starter is much less as compared with the other starting techniques also it provides higher efficiency to motors. It is less costly. Soft starter is useful for AC appliances to give smooth acceleration. Soft starter is taking less time and space. The successful implementation of the proposed hardware scheme will be elaborated by using simulation and experimentation.

REFERENCES

- [1] Majid Ghadami "Soft Starter Modelling For An Induction Motor Drive Starting Study In An Industrial Plant" 2011 UK Sim 5th European Symposium on Computer Modeling and Simulation.
- [2] Adel Gastli " ANN-Based Soft Starting of Voltage-Controlled-
- [3] Fed IM Drive System" IEEE Transactions On Energy Conversion, Vol. 20, No. 3, September 2005.
- [4] G Bhuvaneshwari, Charles S., and ManjulaG.Nair "Power Quality Studies on a Soft Starter for an Induction Motor" Senior Member, IEEE Conference,2008
- [5] SiyuLeng "Soft Starter and Voltage Control of Induction Motor using Floating Capacitor H-Bridge converter" IEEE Transactions on Industry Applications 2016.
- [6] MahrddadTarafdarHagh "Soft Starting of Medium Voltage Induction Motor Using a Resistive Type Fault Current Limiter" Student Members, IEEE Mechatronic Center of Excellence, University of Tabriz 2011.
- [7] B. Sheeba Rani "Electronic Soft Starter for Induction Motor" International Journal Paper. International Journal of Advances in A. Ibrahim "Implementation And Analysis Of Microcontroller Based Soft Starters For Three Phase Induction Motors" EUROCON 2007 The International Conference on "Computer as a Tool" Warsaw, September 9-12.
- [8] Li Guangqiang "Energy Conservation of A Novel Soft Starter Controlled By IGBT for Induction Motor with Minimum Current" Department of Electrical Engineering, Harbin Institute of Technology, Harbin, IEEE Conference 2004.

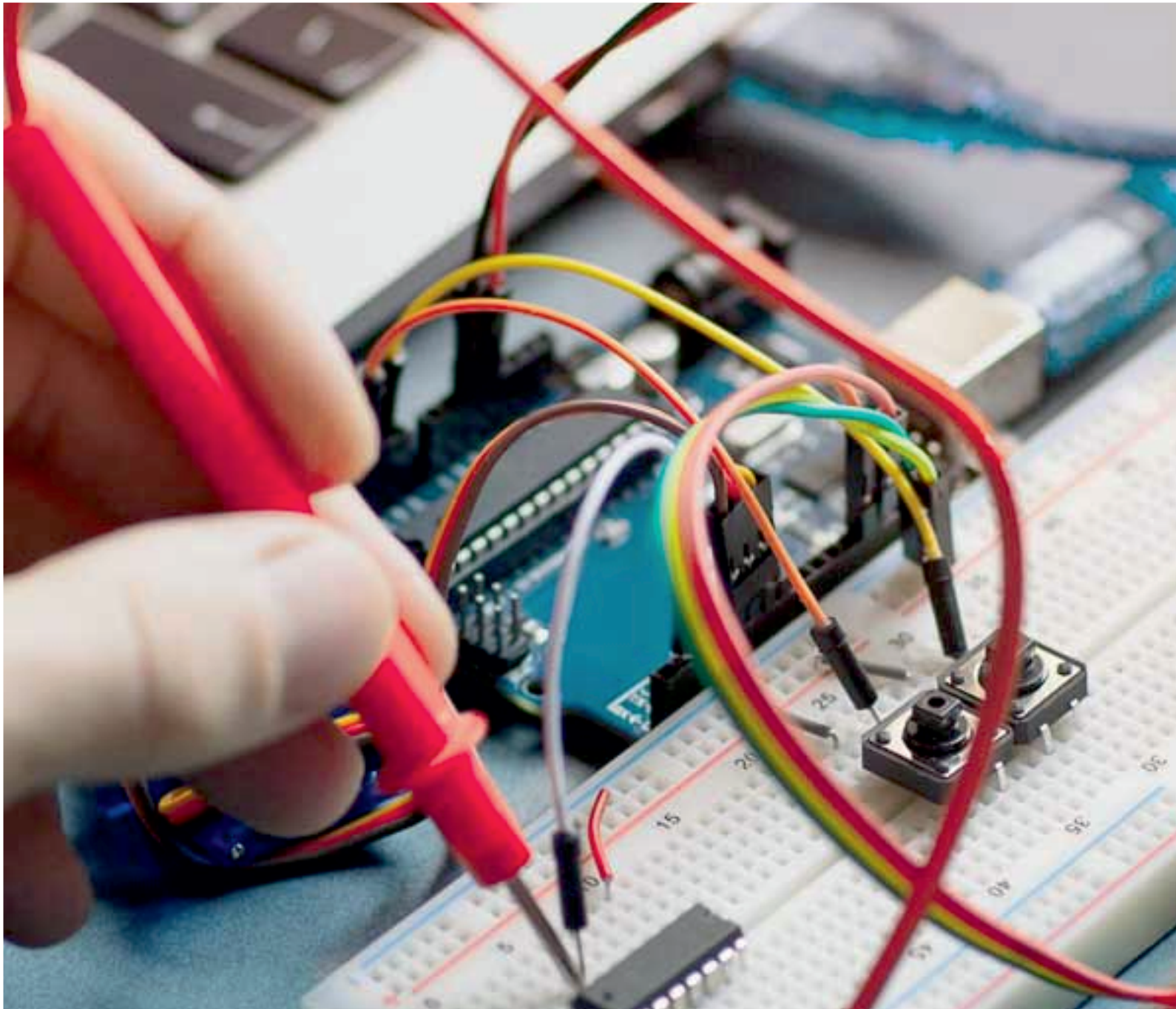

INNO  **SPACE**
SJIF Scientific Journal Impact Factor

Impact Factor:
7.122

ISSN INTERNATIONAL
STANDARD
SERIAL
NUMBER
INDIA



International Journal of Advanced Research

in Electrical, Electronics and Instrumentation Engineering

 **9940 572 462**  **6381 907 438**  **ijareeie@gmail.com**



www.ijareeie.com

Scan to save the contact details