



e-ISSN: 2278-8875

p-ISSN: 2320-3765

# International Journal of Advanced Research

in Electrical, Electronics and Instrumentation Engineering

Volume 9, Issue 12, December 2020

**ISSN** INTERNATIONAL  
STANDARD  
SERIAL  
NUMBER  
INDIA

**Impact Factor: 7.122**

9940 572 462

6381 907 438

ijareeie@gmail.com

www.ijareeie.com



# Review on Working Model of Electric Skateboard

Mitesh Bhavsar<sup>1</sup>, Pratik Tathe<sup>2</sup>, Tejas Bhale<sup>3</sup>, Anurag Gir<sup>4</sup>, Prof. Jadhav M.S.<sup>5</sup>

Diploma Student, Department of Electrical Engineering, Mahatma Gandhi Mission Polytechnic College –  
[MGM's Polytechnic], Aurangabad, Affiliated with MSBTE, Maharashtra, India<sup>1</sup>

Diploma Student, Department of Electrical Engineering, Mahatma Gandhi Mission Polytechnic College –  
[MGM's Polytechnic], Aurangabad, Affiliated with MSBTE, Maharashtra, India<sup>2</sup>

Diploma Student, Department of Electrical Engineering, Mahatma Gandhi Mission Polytechnic College –  
[MGM's Polytechnic], Aurangabad, Affiliated with MSBTE, Maharashtra, India<sup>3</sup>

Diploma Student, Department of Electrical Engineering, Mahatma Gandhi Mission Polytechnic College –  
[MGM's Polytechnic], Aurangabad, Affiliated with MSBTE, Maharashtra, India<sup>4</sup>

Professor, Department of Electrical Engineering, Mahatma Gandhi Mission Polytechnic College –  
[MGM's Polytechnic], Aurangabad, Affiliated with MSBTE, Maharashtra, India<sup>5</sup>

**ABSTRACT:** Due to environmental crisis the ozone layer is depleting day by day and the non-renewable resource take a great time to recover and they are becoming much costly now a days. Thus, electrical vehicle is more suitable option and are more useful they also provide more features and they can be much more reliable. They are environmentally friendly, as they can take energy from natural resources which are unlimited in nature and are easily available to each individual. It also avoids noise pollution and more vibration.

**KEYWORDS:** - BLDC Motor, Controller, Foot Steering, Hall Sensor, Creo 3.0, Ansys 14.0.

## I. INTRODUCTION

Near about 90% and that is the why it is predicted that in 2040-2050 petroleum will be no longer available. so, for the preservation of the non-renewable resources it is necessary to use renewable energy as they can generate unlimited source of energy. An electrical vehicle is a much more valuable resource.

## TYPES OF DRIVING SYSTEM

There are two types of driving condition is applied. They are as follows

- Manual driving system (from upstream to downstream)
- Electrical driving system (from downstream to upstream)

## MANUAL DRIVING

The Newton's third law of motion "In Every Action there is equal and opposite reaction". The manual power is transmitted by applying the force by place one foot on the skateboard and push-off another foot on the ground thus will give a motion on the forward direction of the skateboard. Keep making little push-offs, and pivoting your feet to ride on the board until you slow down.

## ELECTRICAL DRIVING

The electrical power transmission, the power is transmitted to the driving wheel by the help of BLDC motor and the controller which drives on the 48 volt and 15 ampere battery. Thus, the battery gives the DC Current to the controller here the controller gets feedback from the hall sensor inside the hub motor and gives the power to the motor depend upon by giving the signal from the accelerator. Thus, the mechanical brake is applied on the brake drum by the brake shoe. And E- Brake will be applied on the motor by the effect of Hall sensor thus the signal will be given in the acceleration cable.



## COMPONENTS OF ELECTRICAL DRIVE

- Motor.
- Controller.
- Battery.
- Throttle sensor.

## II. LITERATURE SURVEY

AgusPurwadi Two fundamental components in the electric car are the electric motor and its energy storage system. Therefore, we have to protect the battery from anything that can make the battery's life shorter.

Zhidong Zhang Base on PIC16F72, a design of brushless DC motor controller strategy applied to the electric bicycle control system was presented in the paper.

Darshil G. Kothari The Hybrid Bicycle System is a systems project which is used to power an electric hub motor running a bicycle. In this electric hybrid bicycle, the front wheel has a compact & light weight hub motor. It will be having regenerative charge system and solar panels, which enables substantially longer distance power assist

NicolòDaina This paper provides a systematic review of these diverse approaches using a twofold classification electrical transport by the timescale and has difference in designing techniques. it's based on daily analysis of demand; we can identify on how attractive it is. Amongst the most critical there is the lack of realism how charging behavior is represented.

D.F. Flippo Wheel design can be enhanced through experimentation, testing, and iteration. Unfortunately, the time and money needed to test full vehicles is costly. There is a cheaper way if we test incorporate single wheel testing. In a single wheel skateboard, the balance is required and it can be stable on its own it also has motion tilt technology it also contains led and a new algorithm that. To validate this algorithm and explore skid steering enhancement several single wheel skid steering experiments were done and the results were compared to a full vehicle's turning performance.

## III. SKATEBOARD AND E-BOARD



Fig.1. Skateboard

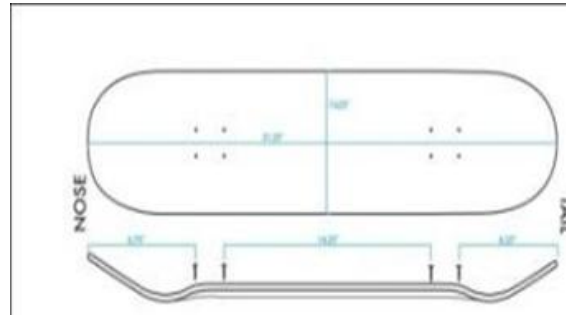

Fig.2. Deck

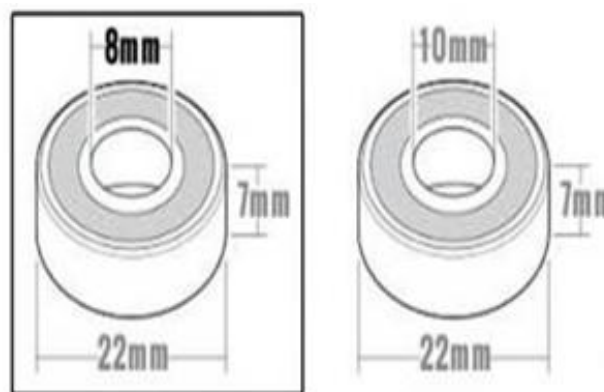

Fig.3. Wheel Types of Skateboard

### Wheel Types of Skateboard

- The Lon Board
- The Cruiser
- Penny Board

A skateboard is a venial that uses physical power from humas to travel and its much more useful an it is faster and does not use any resource.

### Electrical Skateboard



Fig.4. Electric Skateboard

An electrical skateboard is much more efficient device which can be used to travel and is light in wait we can also drive it manually id its discharged.

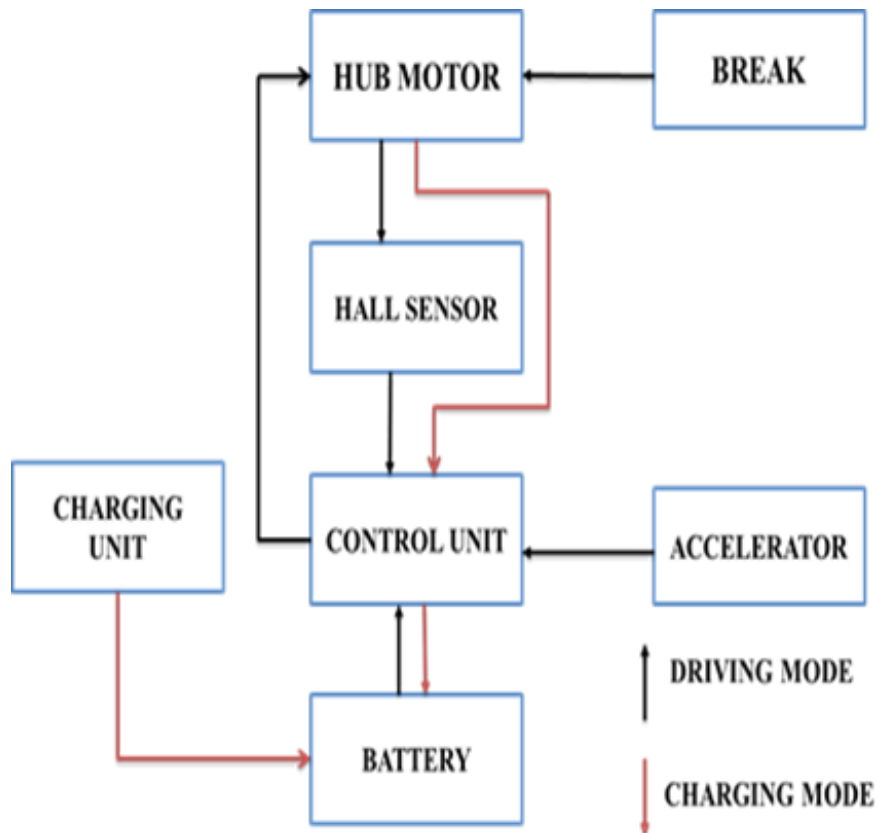

Fig.5. Block Diagram

#### Advantages of E-Board

- Go Uphill with Minimal Effort.
- More Control over Your Speed.
- You Don't Have to Push.

### III. CONCLUSION

It is extremely convenient source of transport. It can work both ways electrically and manually its light weight and portable it can be lifted with a single hand without putting much efforts. its durable in many weather conditions can be used for uphill rides. It can be recharged form anywhere and can be used by anyone. It can go through small place no problem in which many other means of transport cannot go through.

### REFERENCES

1. AgusPurwadi, Jimmy Dozeno, Nana Heryana, "Testing Performance of 10 kW BLDC Motor and LiFePO4 Battery on ITB-1 Electric Car Prototype," Procedia Technology., pp. 1074 – 1082, Nov.2013.
2. Zhidong Zhang, "Design of Controller in Electric Bicycle," Modern Applied Science, Vol. 5, No. 5, October 2011.
3. Darshil G. Kothari, Jaydip C. Patel, Bhavik R. Panchal, "Hybrid Bicycle," IJEDR, ISSN: 2321-9939, Volume 2, Issue 1,2014.
4. Nicolo Daina, Aruna Sivakumar., John W. Polak," Modelling electric vehicles use: a survey on the methods," Renewable and Sustainable Energy Reviews., Vol. 68, pp. 447–460, 2017.M. J. Riezenman.

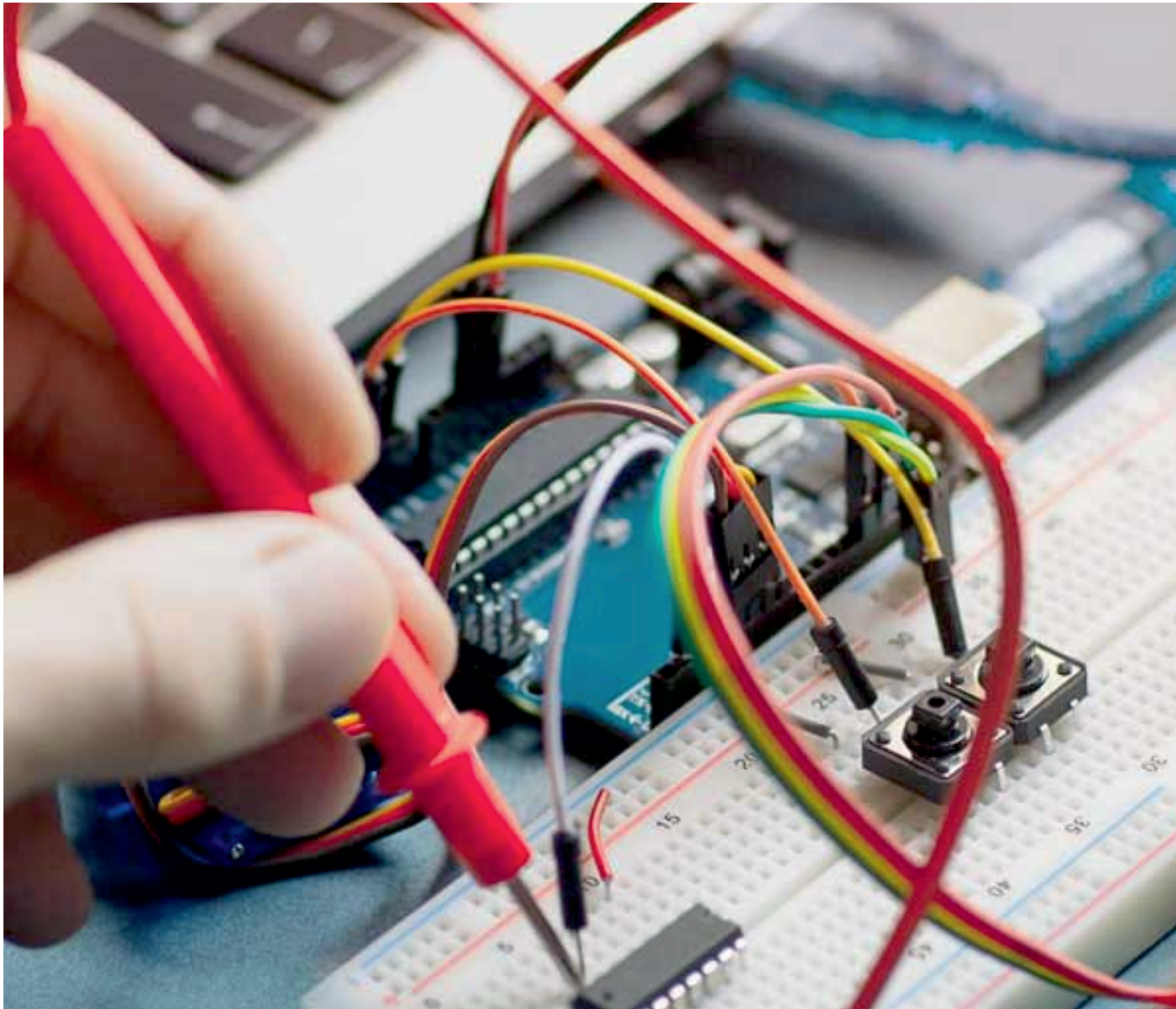

**INNO**  **SPACE**  
SJIF Scientific Journal Impact Factor

**Impact Factor:**  
**7.122**

**ISSN** INTERNATIONAL  
STANDARD  
SERIAL  
NUMBER  
**INDIA**



# **International Journal of Advanced Research**

**in Electrical, Electronics and Instrumentation Engineering**

 **9940 572 462**  **6381 907 438**  **ijareeie@gmail.com**



[www.ijareeie.com](http://www.ijareeie.com)

Scan to save the contact details