



Surveillance Robot Using Microcontroller ESP8266

S.Jagadesh¹, R.Karthikeyan², R.Manojprabhakaran³, R.Ramesh⁴, C.Shanmugam⁵

¹Student, Dept. of ECE, Jansons Institute of Technology, Coimbatore, Tamil Nadu, India

²Student, Dept. of ECE, Jansons Institute of Technology, Coimbatore, Tamil Nadu, India

³Student, Dept. of ECE, Jansons Institute of Technology, Coimbatore, Tamil Nadu, India

⁴Student, Dept. of ECE, Jansons Institute of Technology, Coimbatore, Tamil Nadu, India

⁵Assistant Professor, Dept. of ECE, Jansons Institute of Technology, Coimbatore, Tamil Nadu, India

ABSTRACT: It is known that humans cannot go to the hazardous places, so robots are required where human intervention are nearly impossible. Generally, there are many threats to humans in the dangerous areas. So to avoid those causes, the wireless surveillance robot can be used. This project proposes a working for controlling the wireless surveillance robot using Adafruit server. This project is to build a Wi-Fi controlled mobile robot based on the microcontroller ESP8266. The present condition of the target place can be monitored using various sensors such as DHT11 sensor for humidity and temperature reading. It monitors each area to detect any intrusion using 360 degree camera. This gives a live video stream to the ground station authority. The control of the robot are integrated on a “adafruit” server by using a certain commands. Finally it will be able to control the robot using computer and laptop

KEYWORDS: Spy Robot ; security purpose ;microcontroller Esp8266 ;sensor ;wireless camera

1.INTRODUCTION

Now-a-days tracing and attacking enemies at different areas are very much difficult for the soldiers. There is always a chance for loss of lives of the soldiers during war and emergency situations. With the aim of developing a high technology that serves high speed technology, advanced capacity to control the robots and to device new methods of control theory. The realize above standards some technical improvement along with the need of high performance robot is required to create a faster, reliable, accurate and more intelligent robot which can be devised by advanced control algorithm, robot control devices and new drivers. Therefore to attain the requirements we can use an multimedia to control the user friendly robot. Earlier the robots were controlled through wired networks but now to make robot more users friendly, they are framed to make user commanded work. The design of our project encourages developing a robotic vehicle based on Wi-Fi technology for the remote operation connected with the wireless camera mounted on the robot for monitoring purpose. The robot is embedded with Node mcu esp8266 microcontroller for desired operation and is generally used for monitoring purposes. The transmitting module on PC consist of the push buttons that send the commands to the receiving module for controlling the movement of robot either to right, left, forward, backward. In the receiving module of the robot two motors are interfaced with the esp8266 microcontroller to control its movement via motor driver IC. The Wi-Fi control has a range upto 400m that transmits the signals to the receiver. The receiver collects and decodes the received signals before feeding it to the microcontroller to drive the DC motors via



International Journal of Advanced Research in Electrical, Electronics and Instrumentation Engineering

(A High Impact Factor, Monthly, Peer Reviewed Journal)

Website: www.ijareeie.com

Vol. 8, Issue 3, March 2019

motor drivers. The robot motions left, right, forward, backward. Interfacing is being done between device and Wi-Fi module. Wi-fi module device receives the commands from ESP8266 microcontroller.

II.ISSUES IN EXISTING SYSTEMS

The existing models (RF, Bluetooth & GSM) has various disadvantages, few are that it works only for an Short range coverage area, making it a bit difficult for the Spying purpose or surveillance for long range. Also the wired robots can't be used for spying purpose because of its wired connection, which may restrict the movement of the robot in the vast area of surveillance. In the previous models the video streaming is done as an continuous uninterrupted process hence an lot of unwanted data can be stored .In addition, normal cameras were used for surveillance in war fields, where surveillance during night was an great difficulty. Capturing of images was an unavailable option.[1,7] RF, Bluetooth and GSM modules are not budget fri 3. PROPOSED WORK

This work consists of two sections.

- Robot section and
- Monitoring section.

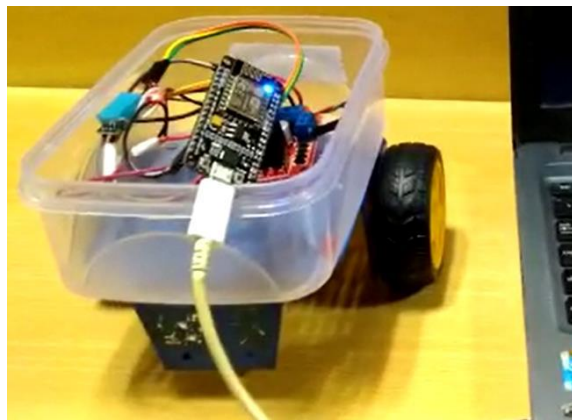

ROBOT

The ESP8266 micro controller is the heart of our project. Robot section consists of various sensors interfaced with ESP8266. An sensor dht11 which is used for identifying the temperature and humidity in that area.It consists of an wireless night vision camera helps to capture images and videos even in dark areas (Low intensity of light availability). Motors are used to control the movement of robot. Wi-Fi module acts as an transceiver helps delivering of data from robot section to monitoring section and vice versa. The Wi-Fi module helps in delivering for long range coverage area that could be very useful for spying purpose in military surveillance. This microcontroller provides low cost and low power connectivity for equipments. An 30rpm motor is used for the movement of robot (Left,Right,Front,Backward).

International Journal of Advanced Research in Electrical, Electronics and Instrumentation Engineering

(A High Impact Factor, Monthly, Peer Reviewed Journal)

Website: www.ijareeie.com

Vol. 8, Issue 3, March 2019

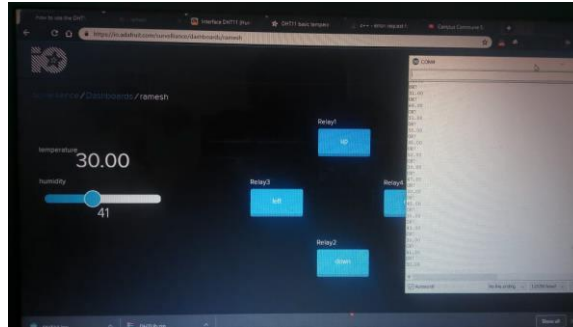

ROBOT CONTROL

Block diagram

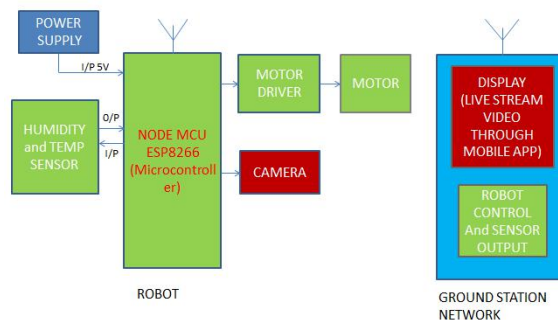

In monitoring section, a common pc is used. An transceiver section (wi-fi module) is connected with laptop.

Advantages:

- It can be used for longer range surveillance.
- Capturing of images during live streaming is possible.
- Night vision camera makes surveillance easy during low lighting conditions.

Applications:

- At the time of war where it can be used to collect information from the enemy terrain and monitor that information at a far secure area, and safely devise a plan for the counter attack.
- Making surveillance of any disaster affected area where human beings can't go.

International Journal of Advanced Research in Electrical, Electronics and Instrumentation Engineering

(A High Impact Factor, Monthly, Peer Reviewed Journal)

Website: www.ijareeie.com

Vol. 8, Issue 3, March 2019

IV. SYSTEM COMPONENTS

A. NODE MCU ESP8266 MICROCONTROLLER:

The ESP8266 is a low-cost Wi-Fi microchip with full TCP/IP stack and microcontroller capability produced by manufacturer Espressif Systems in Shanghai, China. This small module allows microcontrollers to connect to a Wi-Fi network and make simple TCP/IP connections using commands.

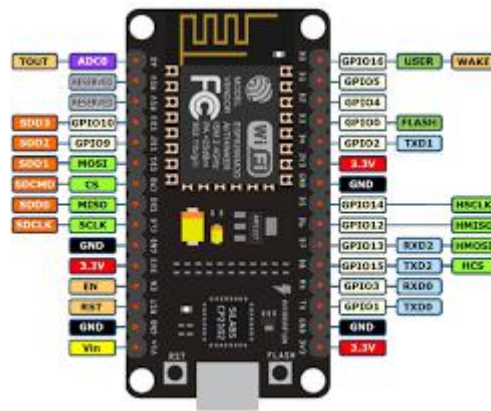

ESP8266 BASIC – An open-source basic interpreter specifically tailored for the internet of things. Self-hosting browser-based development environment.

- Type: 32-bit microcontroller
- CPU: @ 80 MHz (default) or 160 MHz
- Memory: 32 KiB instruction, 80 KiB user data
- Input: 16 GPIO pins

ESP32 The ESP8285 is an ESP8266 with 1 MiB of built-in flash, allowing for single-chip devices capable of connecting to Wi-Fi.

B. WIRELESS CAMERA:

We are using a wireless CCD camera, which are commonly available in the market. This camera works on 5 volts DC supply. The camera has a receiver, which is placed in the remote station. Its output are in the form of audio and video signals. These signals are directly sent to the computer through app. This CCD camera is placed on the robot. The camera captures the audio and video signals and sends those signals to the remote station and with the help of the camera receiver which is connected to the computer through we will be able to see the captured signals. This is a mini wireless monitoring video camera and wireless receiver set for surveillance in the border area. Here we are placing this wireless camera in the combat robot which would be present in the war field.



International Journal of Advanced Research in Electrical, Electronics and Instrumentation Engineering

(A High Impact Factor, Monthly, Peer Reviewed Journal)

Website: www.ijareeie.com

Vol. 8, Issue 3, March 2019



C.DHT11 SENSOR:

The DHT11 is a basic, ultra low-cost digital temperature and humidity sensor. It uses a capacitive humidity sensor and a thermistor to measure the surrounding air, and spits out a digital signal on the data pin (no analog input pins needed). Its fairly simple to use, but requires careful timing to grab data. A humidity sensor (or hygrometer) senses, measures and reports the relative humidity in the air. It therefore measures both moisture and air temperature. The sensor has 3 wires: red (VCC), black (GND) and white (DATA). Connect the red to +5V, the black to GND and the white to the digital pin D10. When MCU sends a start signal, DHT11 changes from the low-power-consumption mode to the running-mode, waiting for MCU completing the start signal. Once it is completed, DHT11 sends a response signal of 40-bit data that include the relative humidity and temperature information to MCU

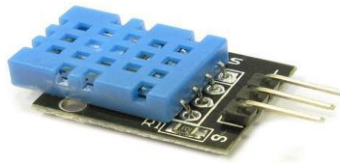

DHT11 sensor

D.MOTOR DRIVER:

A motor driver is a little current amplifier; the function of motor drivers is to take a low-current control signal and then turn it into a higher-current signal that can drive a motor.

- The L298 is an integrated monolithic circuit in a 15-lead Multi watt and PowerSO20 packages.
- It is a high voltage, high current dual full-bridge driver.
- Two enable inputs are provided to enable or disable the device independently of the input signals.
- Wide supply voltage range: 4.5v to 36v



International Journal of Advanced Research in Electrical, Electronics and Instrumentation Engineering

(A High Impact Factor, Monthly, Peer Reviewed Journal)

Website: www.ijareeie.com

Vol. 8, Issue 3, March 2019

- Separate Input – logic supply and TTL
- Compatible.

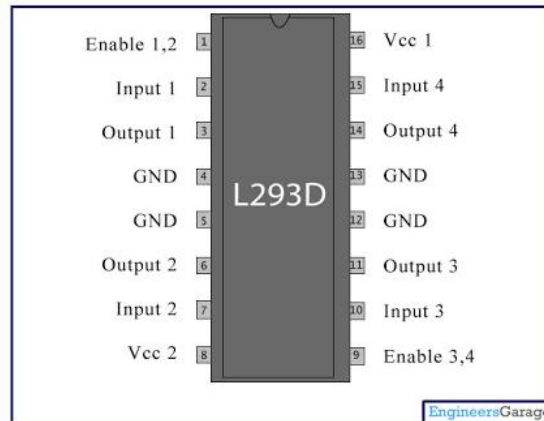

D.WI-FI MODULE:

The ESP8266 WiFi Module is a self contained SOC with integrated TCP/IP protocol stack that can give any microcontroller access to your WiFi network. The ESP8266 is capable of either hosting an application or offloading all Wi-Fi networking functions from another application processor.

V. CONCLUSION

This type of robot can perform difficult and repetitive works for humans. It can have a very risky job and such dangerous job could be done by using small spy robot. But it is useful to check and look out the places where dangerous to the humans. Spy robot can also be used in searching people who are in building destroyed by the earthquake. Because of the wireless camera is installed in spy robots, it can be used remotely to enter and exit dangerous place that human cannot. When the user controls by remote controller, the spy robot will move to desired destination and spy images around the robot. The user can check and recommend from computer with the wireless remote controller.

VI. FUTURE SCOPE

To improve the sensors in the border area. Also improve the performance of the robot .And attaching the gps in the robot to determine the location of the robot.

REFERENCES

1. Pravin ,Akansha,"Internet of things based robotic arm"ISSN:2395-0056,vol:04 issue:03|march 2017.
2. Jun Zhang, Guangming Song, "An Indoor Security with a Jumping Robot as the
3. Surveillance Terminal", IEEE Transactions on Consumer Electronics, vol. 57, no. 4, November 2016.
4. Keerthi Premkumar, K Gerard Joe Nigel, "Smart Phone Based Robotic Arm Control Using IOT Android and Wi-Fi", IEEE Sponsored 2nd International Conference on Innovation in
5. Information Embedded and Communication Systems, 2016.
6. K. Pooventhan, R. Achuthaperumal and C. Manoj Balajee, "Surveillance Robot Using Multi Sensor Network", International Journal of Innovative Research in Electrical, Electronics, Instrumentation and Control, vol. 3, no. 2, pp. 113-115, 2015.
7. Dhiraj Patel Singh, "Mobile Operated Spy Robot" International journal of emerging technology and advanced engineering (IJETA), 2013.
8. Lokesh Mehta, Pawan Sharma, "Spy
9. Night Vision Robot with Moving
10. Wireless Video Camera". International journal of research in engineering technology and management (IJRETM), 2014.



ISSN (Print) : 2320 – 3765
ISSN (Online): 2278 – 8875

International Journal of Advanced Research in Electrical, Electronics and Instrumentation Engineering

(A High Impact Factor, Monthly, Peer Reviewed Journal)

Website: www.ijareeie.com

Vol. 8, Issue 3, March 2019

11. AaruniJha, Apoorva Singh,
12. RavinderTurna, Sakshi Chauhan —"War
13. Field Spying Robot With Night Vision
14. Camera" Journal of Network Communication and EmergingTechnologies (JNCET) .
15. Diksha Shakya, Jyoti, Shantanu Gupta, Swati Rajput, "Spy Robot With Wireless Camera Using GSM".International
16. Research Journal of Engineering and Technology (IRJET) Volume: 04 Issue: 03 Mar -2017
17. Selvam, M. "Smart phone based robotic control for surveillance applications."Dept. of ECE, Karpagam University, Coimbatore, Tamil Nadu, International Journal of Research in Engineering and Technology (2014).
18. Jenifer, T. Maria, et al. "Mobile Robot Temperature Monitoring System Controlled by Android Application via Bluetooth." International Journal on Advanced Computer Theory and Engineering (IJACTE) (2013).