



ISSN (Print) : 2320 – 3765  
ISSN (Online): 2278 – 8875

## International Journal of Advanced Research in Electrical, Electronics and Instrumentation Engineering

(An ISO 3297: 2007 Certified Organization)

Website: [www.ijareeie.com](http://www.ijareeie.com)

Vol. 6, Issue 3, March 2017

# Design of Hybrid Electric Vehicles Using Solar and Wind Energy with Arduino Processor

T.Vignesh<sup>(1)</sup>, S.Sathishkumar<sup>(2)</sup>, D.Silambarasan<sup>(3)</sup>

Assistant Professor, Dept. of Electrical and Electronics Engineering, Jay Shriram Group of Institutions, Tirupur,  
Tamilnadu, India<sup>(1)</sup>

UG Scholar, Dept. of Electrical and Electronics Engineering, Jay Shriram Group of Institutions, Tirupur,  
Tamilnadu, India<sup>2,3</sup>.

**ABSTRACT:** This paper proposes a Hybrid Electric Vehicle (HEV) system which solves the major problems of fuel and pollution. The renewable energy is vital for today's world as in near future the non renewable sources that we are using are going to get exhausted. The hybrid electric vehicle is a step in saving these non renewable sources of energy. The basic principle of solar car is to use energy that is stored in a battery during and after charging it from a solar panel. Power generated by renewable energy sources has recently become one of the most promising solutions for the electrification of islands and remote rural areas. But high dependency on weather conditions and the unpredictable nature of these renewable energy sources are the main drawbacks. To overcome this weakness, different green energy sources and power electronic converters need to be integrated with each other. The charged batteries are used to drive the motor which serves here as an engine and moves the vehicle in reverse or forward direction. This idea, in future, may help to protect our fuels from getting extinguished.

**KEYWORDS:** solar panel, wind turbine, charge controller, battery, DC-DC boost converter, DC-AC power converter (inverter circuit), arduino processor and BLDC motor

### I.INTRODUCTION

This paper discusses about the usage of solar energy and wind energy to power up the vehicle. In order to achieve the required voltage, the Photo Voltaic (PV) Module may be connected either in parallel or series, but its costlier. Thus to make it cost effective, power converters and batteries are been used. The electrical charge is consolidated from the PV panel and wind turbine and directed to the output terminals to produce low voltage (Direct Current).

An electric vehicle is pollution free and is efficient at low speed conditions mainly in high traffic areas. But battery charging is time consuming. The charge controllers direct this power acquired from the solar panel and wind turbines to the batteries.

According to the state of the battery, the charging is done, so as to avoid overcharging and deep discharge. The voltage is then boosted up using the boost power converter, ultimately running the BLDC motor which is used as the drive motor for our vehicle application. In the course work, the characteristic features of the components: solar panel, wind turbine, charge controller, battery, interleaved converter, arduino processor and BLDC motor required for the vehicle application were studied in real time and also were modelled individually and the complete hardware integration of the system into meet up the application's requirement.

# International Journal of Advanced Research in Electrical, Electronics and Instrumentation Engineering

(An ISO 3297: 2007 Certified Organization)

Website: [www.ijareeie.com](http://www.ijareeie.com)

Vol. 6, Issue 3, March 2017

## 1.1 Block Diagram

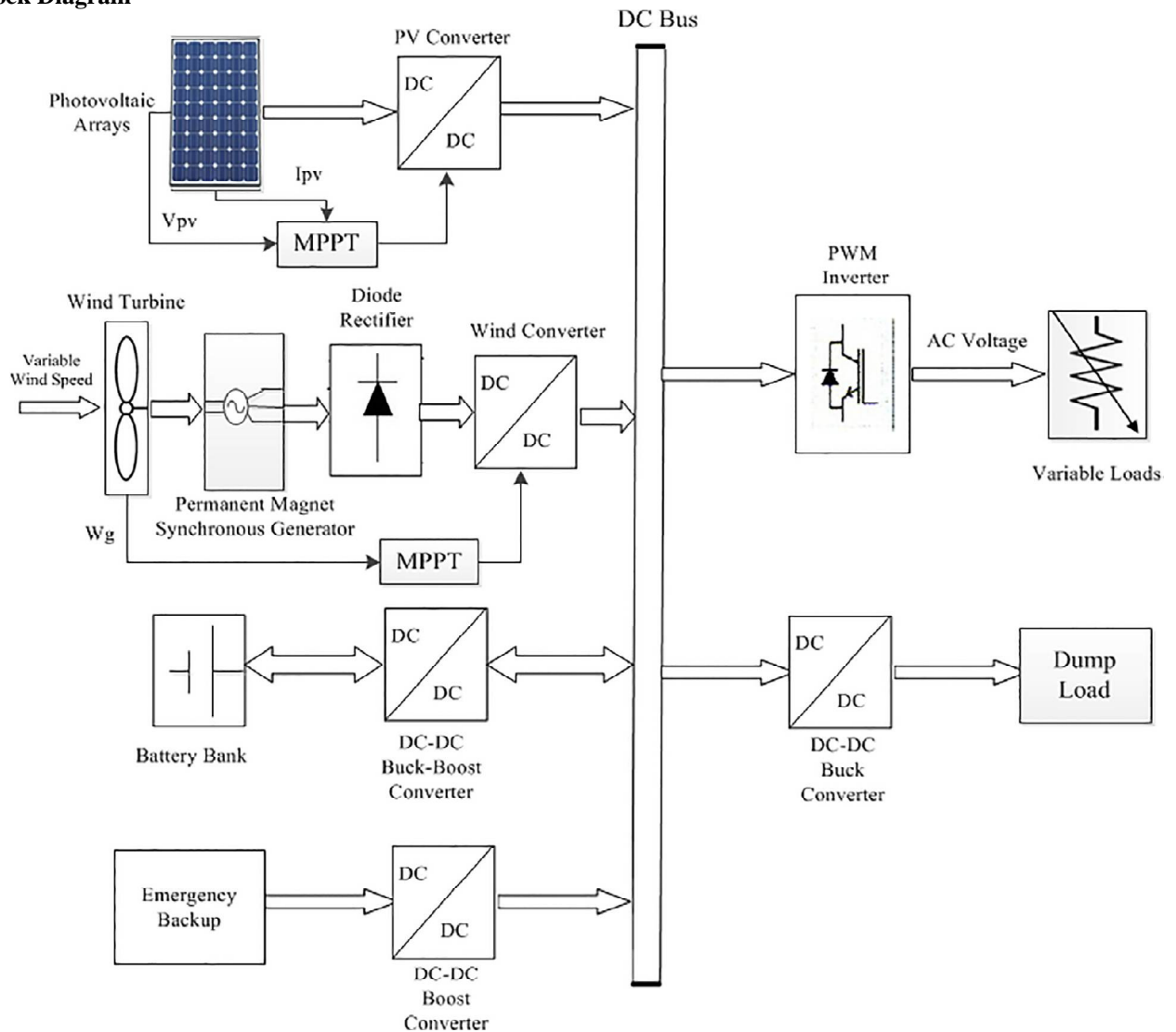

**Figure 1:** Block diagram of the proposed PV-Wind hybrid system.

The above diagram gives an overview of the working of hybrid electric vehicle. Energy from Sun is captured by the solar panels and energy from wind is captured by wind turbine is converted to electrical energy. The electrical energy thus formed is being fed to the batteries that get charged and is used to run PMLDC motor. The shaft of the motor is connected to the rear wheel of the vehicle through chain sprocket.

The batteries are initially fully charged and thereafter they are charged by panels and wind turbines. This helps in completing the charging-discharging cycle of the batteries, which is very important for proper working of batteries.

## II.RENEWABLE ENERGY SOURCES

### 2.1 Solar Power Systems

The solar panel used in the solar vehicle is of the rating of 140 WP. The main point that should be kept in mind while making a solar vehicle is the mounting of the solar panel.

The panel should be mounted in such a way that it receives maximum sun rays so that it gives its maximum efficiency.

For the vehicle designed, we have mounted the solar panel in SOUTH-EAST direction during the time 6 AM to 11.30 AM. After that the panel is changed to a SOUTH-WEST direction. We have used the conventional roof-top mounting technique for the solar panel A 6 feet by 4 feet plywood has been used and mounted on the top of vehicle.

The solar cell used in the vehicle is multi-crystalline. The reason behind using the multi crystalline cell is that it is more efficient than the mono-crystalline cell and the rate of conversion of energy is faster in the former. 36 cells are used in the PV module of this vehicle.

The upper frame of this solar module is covered with thick glass to avoid breakage of the solar panel.

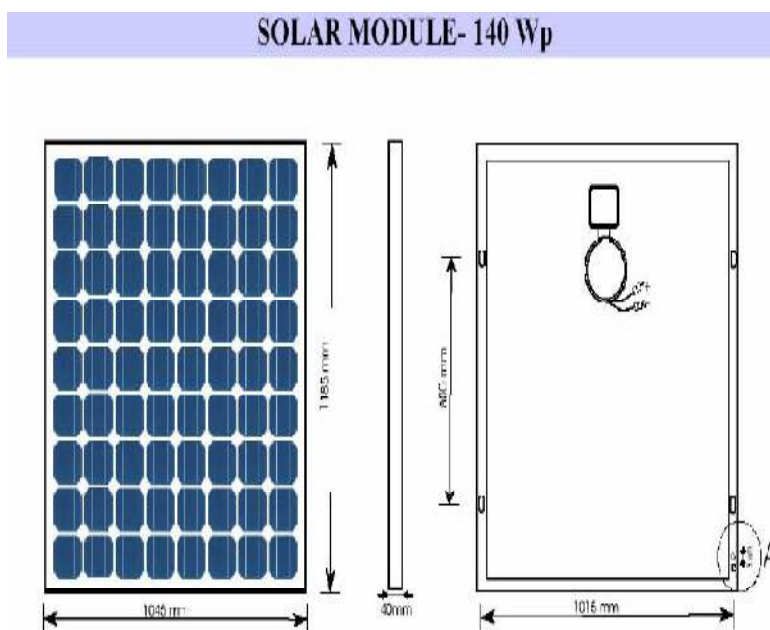

**Figure 2:** The diagrammatic representation of the panel and the panel connections

Cells are further connected in series or/and parallel combination to form a PV array. Different PV cell configurations can be used to illustrate the different V-I characteristic curves such as single diode model, two diode model, and Rs-Rp model. But due to the degree of accuracy and simplicity, the single diode model has been used in some previous works. For this reason, the PV cell single diode configuration has been selected for this study.

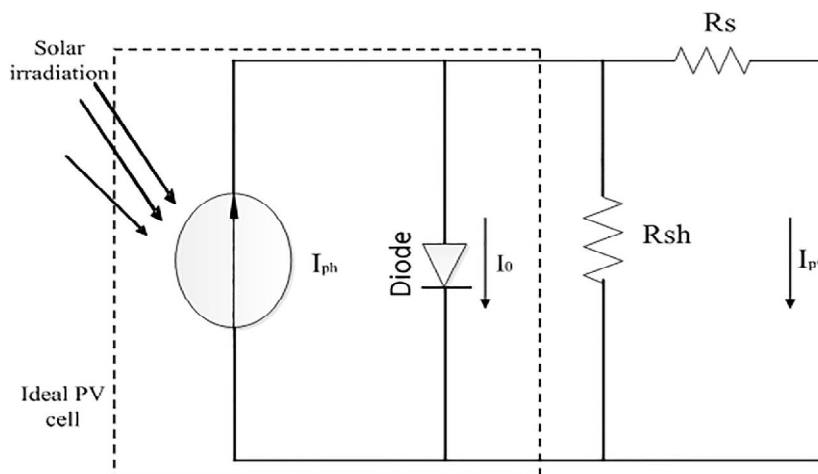

Figure3: Equivalent circuit diagram of a single-diode PV model.

## 2.2 Wind Power System

The wind turbine generally used in this proposed system is of the horizontal axial wind turbine which is coupled with the permanent magnet synchronous machine. The speed of the wind and the direction of the wind are governed.

Normally the pitch angle is given as 0(deg) it may increase or decrease according to the wind direction. The velocity of the wind is maintained constant with the help of speed increaser and constant.

Both of these are connected to the shaft with the help of the switch which is controlled manually. Normally the constant is used for the system to generate in case of insufficiency the speed increaser is connected. The wind speed and the pitch angle are constantly verified. The generator output power is Power Flow Management and Control of Hybrid Wind / PV and Battery Power System connected to the universal bridge which converts the ac power to the dc power.

### 2.2.1 Wind Turbine

A wind turbine is a machine for converting the kinetic energy in wind into mechanical energy. Wind turbines can be separated into two basic types based on the axis about which the turbine rotates. Wind turbines can also be classified by the location in which they are used as Onshore, Offshore, and aerial wind turbines.

### 2.2.2 Wind Power Modeling

The block diagram in figure 3 shows the conversion process of wind energy to electrical energy.

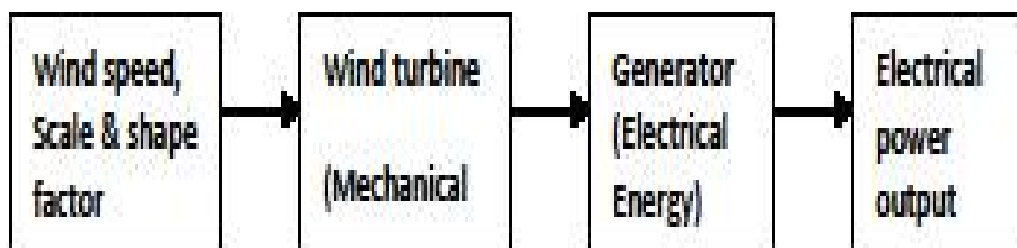

Figure 4: Energy conversions from Wind to Electrical

## III. HYBRID ENERGY SYSTEMS

Solar-Wind hybrid Power system is the combined power generating system by wind mill and solar energy panel. It also includes a battery which is used to store the energy generated from both the sources. Using this system

# International Journal of Advanced Research in Electrical, Electronics and Instrumentation Engineering

(An ISO 3297: 2007 Certified Organization)

Website: [www.ijareeie.com](http://www.ijareeie.com)

Vol. 6, Issue 3, March 2017

power generation by windmill when wind source is available and generation from PV module when light radiation is available can be achieved. Both units can be generated power when both sources are available. By providing the battery uninterrupted power supply is possible when both sources are idle.

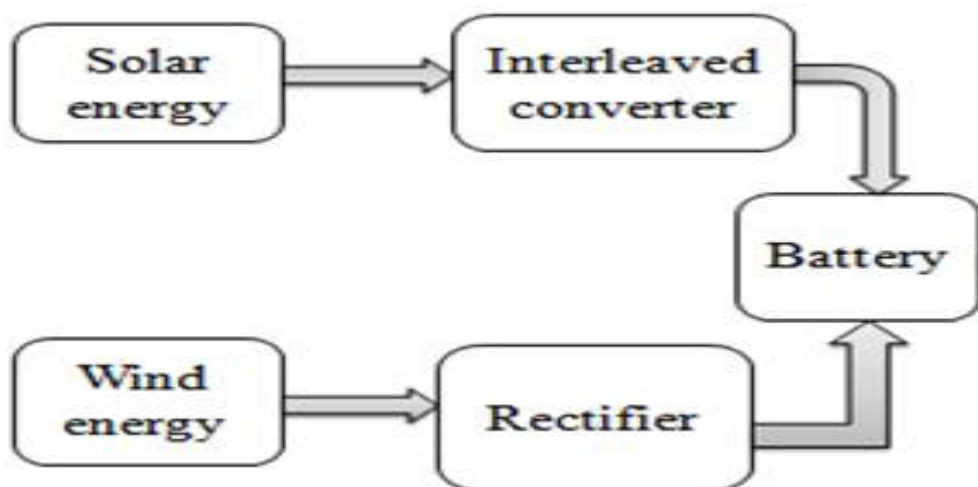

Figure 5: Hybrid Energy System

### 3.1 Solar panel

Solar panel is used to convert solar radiation to electrical energy. The physical of PV cell is very similar to that of the classical diode with a PN junction formed by semiconductor material.

When the junction absorbs light, the energy of absorbed photon is transferred to the electron-proton system of the material, creating charge carriers that are separated at the junction.

The charge carriers in the junction region create a potential gradient, get accelerated under the electric field, and circulate as current through an external circuit.

Solar array or panel is a group of several modules electrically connected in series parallel combination to generate the required current and voltage. Solar panels are the medium to convert solar power into electrical power.

### 3.2 Wind turbine

Wind turbine is that system which extracts energy from wind by rotation of the blades of the wind turbine. Basically wind turbine has two types one is vertical and another is horizontal.

As the wind speed increases power generation is also increased. The power generated from wind is not continuous its fluctuating. For obtain the non-fluctuating power we have to store in battery and then provide it to the load.

### 3.3 Interleaved converters

Interleaved power converters can be very beneficial for high performance electrical equipment applications. Reductions in size and electromagnetic emission along with an increase in efficiency, transient response, and reliability are among the many advantages to using such converters.

### 3.4 Rectifier

Rectifier is the process of converting an ac power into dc power. In this hybrid energy system, the ac power from wind turbine is in the form of variable and it is converted into dc with the help of rectifier and then stored in battery.



# International Journal of Advanced Research in Electrical, Electronics and Instrumentation Engineering

(An ISO 3297: 2007 Certified Organization)

Website: [www.ijareeie.com](http://www.ijareeie.com)

Vol. 6, Issue 3, March 2017

## 3.5 Battery Bank

We have to choose battery bank size per the load requirement so that it should fulfill the requirement of load for calculating the battery bank size. For increase in battery bank size we need to connect cell in series so that we can get the larger battery bank size.

The batteries in the system provide to store the electricity that is generated from the wind or the solar power. Any required capacity can be obtained by serial or parallel connections of the batteries.

The battery that provides the most advantageous operation in the solar and wind power systems are maintenance free dry type and utilizes the special electrolytes. These batteries provide a perfect performance for long discharges. Charging and discharging takes place in this battery.

## IV. CLOSED LOOP SYSTEMS

### 4.1 Arduino Processor

The Arduino microcontroller is an easy to use yet powerful single board computer that has gained considerable traction in the hobby and professional market. The Arduino is open-source, which means hardware is reasonably priced and development software is free.

This guide is for students in ME 2011, or students anywhere who are confronting the Arduino for the first time. The Arduino programming language is a simplified version of C/C++. If you know C, programming the Arduino will be familiar. If you do not know C, no need to worry as only a few commands are needed to perform useful functions.

When you reconnect the battery, the last program you stored will run. This means that you connect the board to the host PC to develop and debug your program, but once that is done, you no longer need the PC to run the program.

The Arduino is open-source, which means hardware is reasonably priced and development software is free. This guide covers the Arduino Uno board (Sparkfun DEV-09950, \$29.95), a good choice for students and educators.

An important feature of the Arduino is that you can create a control program on the host PC, download it to the Arduino and it will run automatically.

Remove the USB cable connection to the PC, and the program will still run from the top each time you push the reset button. Remove the battery and put the Arduino board in a closet for six months.

When you reconnect the battery, the last program you stored will run. This means that you connect the board to the host PC to develop and debug your program, but once that is done, you no longer need the PC to run the program.

The graphical code of controller is written in the LabVIEW. By varying the load conditions in the LabVIEW, the corresponding gate signal duty ratio is generated and the output is given to the PWM pins of Arduino.

The PWM pulses corresponding to this duty ratio are generated from the Arduino. The LabVIEW is interfaced Arduino controller which works in open loop as explained above.

Based on above simulation results, it can conclude that proposed hybrid system can be able to deliver a suitable quality of voltage and current to the load with the help of inverter switching and a passive L-C filter.

The total harmonics distortion in the output voltage and current at load side is about 1.7% and 1.55%, respectively, which illustrates the good quality of voltage and current generated at the load side end.

Finally, it established that the proposed hybrid system can successfully accommodate solar irradiation, wind speed and load changes, and the power management algorithm can efficiently track the hybrid power and load changes.

# International Journal of Advanced Research in Electrical, Electronics and Instrumentation Engineering

(An ISO 3297: 2007 Certified Organization)

Website: [www.ijareeie.com](http://www.ijareeie.com)

Vol. 6, Issue 3, March 2017

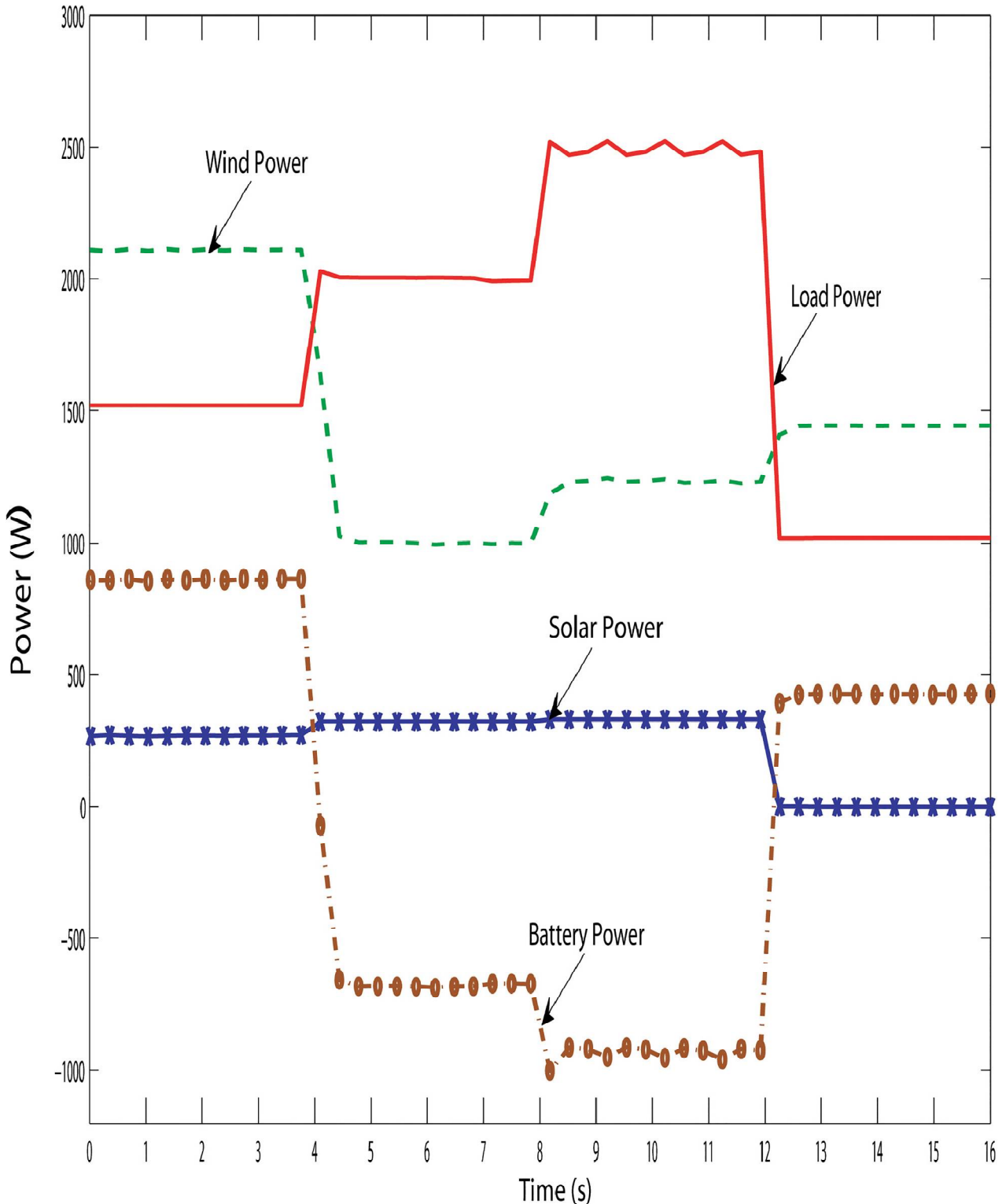

Figure 6: Powers distribution curve of the PV-wind hybrid system during the variation in hybrid power with fixed load.

# International Journal of Advanced Research in Electrical, Electronics and Instrumentation Engineering

(An ISO 3297: 2007 Certified Organization)

Website: [www.ijareeie.com](http://www.ijareeie.com)

Vol. 6, Issue 3, March 2017

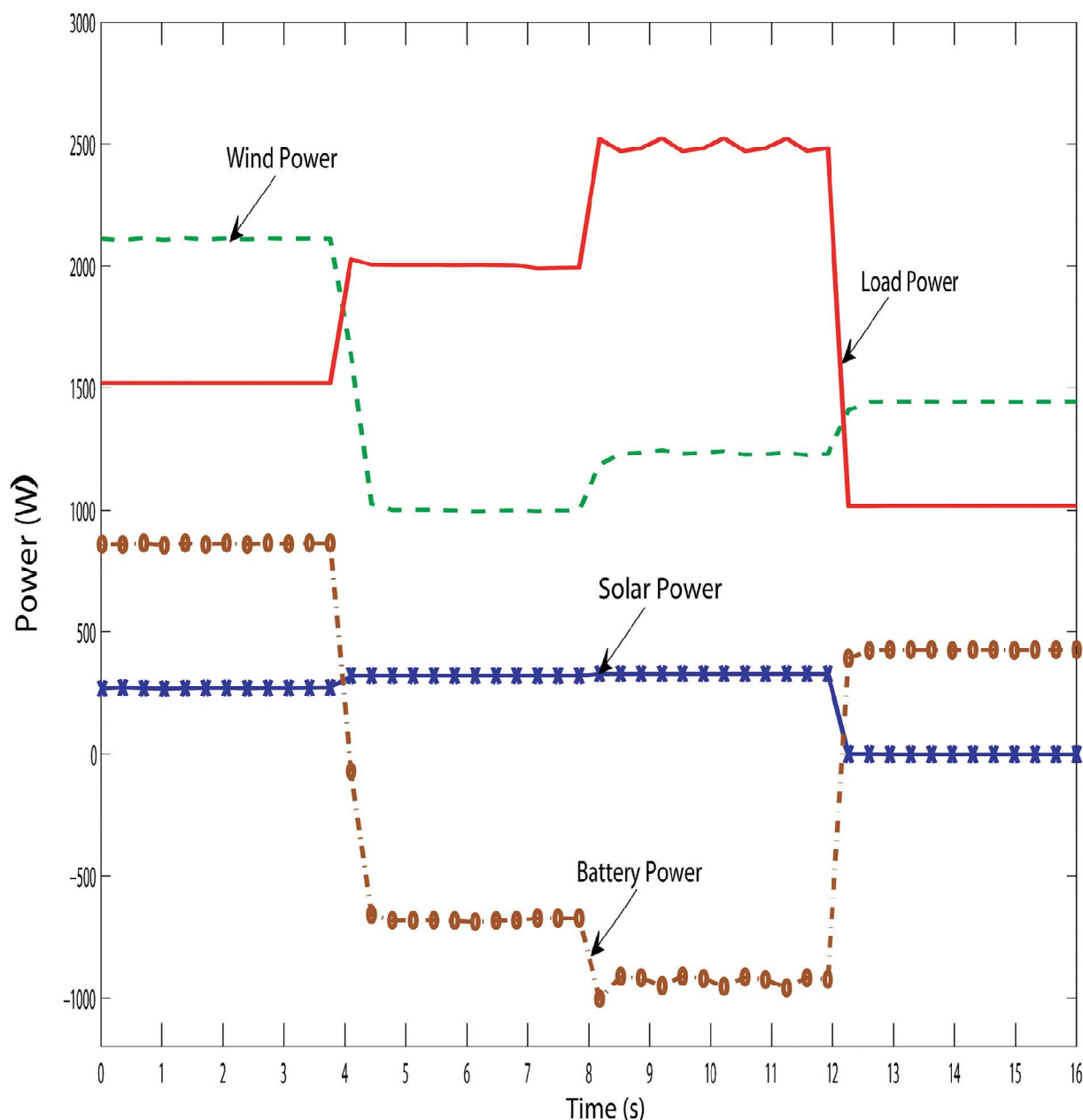

**Figure 7:** Powers distribution curve of the PV-wind hybrid system during the variation in load with fixed hybrid power.

## V. CONCLUSION

A novel hybrid PV-wind renewable power generation system with appropriate power management algorithm has been designed and modeled in this paper for standalone island uses in the absence of electric power grid. The power available from green energy sources is highly dependent on weather conditions such as solar irradiations and wind speed. In this paper, a PV system integrated with a wind turbine and battery bank using a novel topology to overcome this deficiency. This standalone hybrid topology shows excellent performance under varying load power requirement,





ISSN (Print) : 2320 – 3765  
ISSN (Online): 2278 – 8875

# International Journal of Advanced Research in Electrical, Electronics and Instrumentation Engineering

(An ISO 3297: 2007 Certified Organization)

Website: [www.ijareeie.com](http://www.ijareeie.com)

Vol. 6, Issue 3, March 2017

solar irradiation and wind speeds where solar irradiation and wind speed . Powers distribution curve of the PV-data are based on real world records.

Based on the simulation results and analysis, it could be concluded that the proposed hybrid system can be satisfactorily used in the Pehentian Islands. Future work should aim at setting up the proposed hybrid standalone PV-wind system in the University of Malaya laboratory to verify the simulation results.

## REFERENCES

- 1.A. Adejumobi, S.G. Oyagbinrin, F. G. Akinboro & M.B. Olajide, "Hybrid Solar and Wind Power: An Essential for Information Communication Technology Infrastructure and people in rural communities", IJRRAS, Volume 9, Issue1, October 2011, pp 130-138.
- 2.Almaktar M, Rahman HA, Hassan MY, Omar WZW. (2013). Photovoltaic technology in Malaysia: past, present, and future plan. International Journal of Sustainable Energy, (ahead-of-print), 1–13.
- 3.Clifton J, Boruff BJ. (2010). Assessing the potential for concentrated solar power development in rural Australia. Energy Policy, 38(9), 5272–5280.
- 4.Hu X, Sun F, Zou Y. (2013). Comparison between two model-based algorithms for Li-ion battery SOC estimation in electric vehicles. Simulation Modelling Practice and Theory of Li-ion battery for electrified vehicles. Energy, 64, 953–960.
- 5.Kavita Sharma, Prateek Haksar "Designing of Hybrid Power Generation System using Wind Energy- Photovoltaic Solar Energy- Solar Energy with Nanoantenna" Internationa Journal of Engineering Research And Applications (IJERA) Vol. 2, Issue 1,Jan-Feb 2012, pp.812-815 .
- 6.Nahidul Hoque Samrat,Norhafizan Ahmad, Imtiaz Ahmed Choudhury, Zahari Taha  
" Technical Study of a Standalone Photovoltaic–Wind Energy Based Hybrid Power Supply Systems for Island Electrification in Malaysia",Journal 2015.
- 7.Sandeep Kumar, Vijay Kumar Garg, "A Hybrid model of Solar-Wind Power Generation System", International Journal of Advanced Research in Electrical, Electronics and Instrumentation Engineering (IJAREEIE), Vol. 2, Issue 8, August 2013, pp. 4107-4016.
- 8.Samrat NH, Ahmad NB, Choudhury IA, Taha ZB, Prospect of Wave Energy in Malaysia, in Proceedings of the IEEE 8th International Power Engineering and Optimization Conference, 2014.
9. Z. Wang, Z. Zou, and Y. Zheng, "Design and control of a photovoltaic energy and SMES hybrid system with current source grid inverter," IEEE Trans. Appl. Supercond. vol. 23, no. 3, pp. 1051- 1055, 2013. doi:10.1109/TASC.2013.2250172.