



ISSN (Print) : 2320 – 3765
ISSN (Online): 2278 – 8875

International Journal of Advanced Research in Electrical, Electronics and Instrumentation Engineering

(An UGC Approved Journal)

Website: www.ijareeie.com

Vol. 6, Issue 8, August 2017

IoT Based Smart Village as a Model for Swatch Bharat with a Web App Using Raspberry Pi

Dr.T.C.Thanuja¹, Shruti B Haibatti²

Professor, Dept. of VLSI Design and Embedded Systems, VTU, Belagavi, Karnataka, India¹

PG Student, Dept. of VLSI Design and Embedded Systems, VTU, Belagavi, Karnataka, India²

ABSTRACT: Basically, the system consists of a centralized Raspberry pi interfaced with many sensors for making the village cleaner and smarter. The paper aims to bring smartness in any village such as smart garbage management; intensity based street light monitoring and digital water supply system. The Internet of Things (IoT) shall be able to incorporate transparently and seamlessly a large number of different and heterogeneous end systems, while providing open access to selected subsets of data for the development of a plethora of digital services. Building a general architecture for the IoT is hence a very complex task, mainly because of the extremely large variety of devices, link layer technologies, and services that may be involved in such a system. In this paper, we focus specifically to urban IoT systems that, while still being quite a broad category, are characterized by their specific application domain. Urban IoT, in-fact, are designed to support the Smart village vision, which aims at exploiting the most advanced communication technologies to support added-value services for the administration of the city and for the citizens. This paper hence provides a comprehensive survey of the enabling technologies, protocol sand architecture for an urban IoT.

KEYWORDS: Raspberry Pi, IOT, IR sensor, UV sensor, LDR, Ph sensor, Wi-Fi.

I.INTRODUCTION

In the present scenario garbage removal system is managed through the trucks coming door to door to collect the waste. Garbage collection is restricted to particular time in a day, hence the waste can be found in an open space, hence this leads to an environmental pollution. Other issue is the street light monitoring system which is the major requirement in today's life, it is required to switch ON/OFF light manually when not in use, this system gives a solution to minimize power consumption and manpower.

In the manual water control system one has ON and OFF the switch and this leads to unnecessary wastage of water. The "swatch bharat" project influence to design IoT based smart village which would probably solve the basic issues with the proposed model.

The system consists of a centralized Raspberry pi interfaced with many sensors for providing a model to make the villages clean and smart. This paper presents a smart garbage management, automatic street light control and water control system with the check for quality of water.

The IoT is a recent communication paradigm that envisions a near future in which the objects of everyday life will be equipped with micro-controllers, transceivers for digital communication, and suitable protocol stacks that will make them able to communicate with one another and with the users, becoming an integral part of the Internet. The IoT concept, hence, aims at making the Internet even more immersive and pervasive. Furthermore, by enabling easy access and interaction with a wide variety of devices, for instance, home appliances, surveillance cameras, monitoring sensors, actuators, displays, vehicles, and so on, the IoT will foster the development of a number of applications that make use of the potentially enormous amount and variety of data generated by such objects to provide new services to citizens, companies, and public administrations. This paradigm indeed finds application in many different domains, such as home



International Journal of Advanced Research in Electrical, Electronics and Instrumentation Engineering

(An UGC Approved Journal)

Website: www.ijareeie.com

Vol. 6, Issue 8, August 2017

automation, industrial automation, medical aids, mobile health care, elderly assistance, intelligent energy management and smart grids, automotive, traffic management and many others.

Thus this paper describes the implementation of the model, flow chart. It also discusses the different modules used to achieve the desired output actions. The next part of the paper gives the quick look of obtained results as well as overall system results after including all the modules together. The conclusion derived after designing a smart village system along with future scope for further modification is discussed in the later part.

II.LITERATURE SURVEY

In this paper, competence of the street lightning system is improved by ZigBee and sensors. Less energy utilization by the system is done. But the range of communication of the ZigBee is almost 50 meters. hence, ZigBee is not suitable for street lightning system [1]. In [2] the camera and the load sensor are used, which are placed at the bottom of the trash can and the camera takes the continuous snapshot of bin and the output of camera and load sensor is compared with threshold level. The authors in [3] used an ultrasonic sensor and GSM. The sensor measures the level of garbage when the waste crosses the level, sensor receives the data of the filled level and then it is sent to the authorized person through GSM to take a further action. In [4] the light sensor and photo electric sensor was used. This system was designed to detect the vehicles on highways to switch ON and OFF the light to save the energy. But during the night all the lights on the highways remain ON for, hence waste of power, and there is a lot of power becomes waste when there is no movement of vehicle. In [5], the authors include the garbage and street light monitoring to reduce power consumption and manpower.

III.DESIGNING A MODEL FOR SWATCH BHARAT

Figure 1 shows the swatch bharat model which includes centralized controller interfaced with sensors

Garbage monitoring system: In the garbage monitoring IR sensor is placed at the top of the dustbin once the garbage reaches to the threshold level that is IR=1 that is high the sensor sense the level of garbage and intimate to the authorized person through the web app. And the authorized person sends the truck to unload the garbage bin.

Automatic street light control :LDR and IR sensor are used. The LDR sensor works when the intensity of light becomes low. The IR sensor is used for detecting the vehicles/humans, once the vehicle is detected on the street the light becomes automatically turn on through LDR sensor so from this automatic street light control power can be saved.

Automatic water control system and the nature of water: and it uses the UV,IR and pH sensor for the supply of water and to check the quality of water the IR sensor and UV sensor is placed on top of the tank when the IR=1 it shows that the water tank is filled then relay gets automatically OFF and when UV sensor gets low then the relay turns ON and the water starts to fill in the tank so the water and energy can be saved and also the quality of water and intimated to the authorized person as well as the villagers . This all scenarios are loaded in web page and the LCD through the IoT.

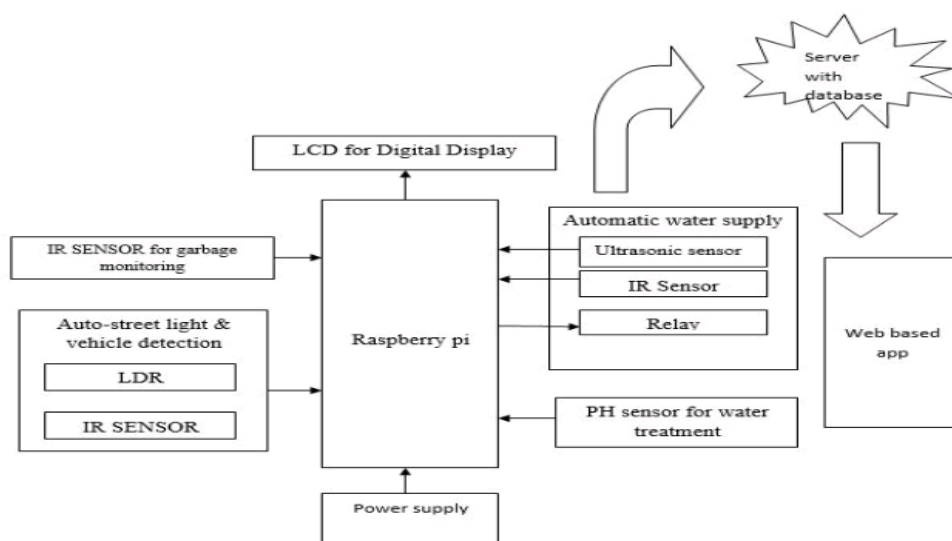

Figure 1 Functional block diagram of the proposed swatch bharat model.



International Journal of Advanced Research in Electrical, Electronics and Instrumentation Engineering

(An UGC Approved Journal)

Website: www.ijareeie.com

Vol. 6, Issue 8, August 2017

Flow chart of system is shown in below figure

- Initializing the system
- check IR sensor status garbage container is filled or empty
- if it is not filled wait for IR sensor output
- if it is filled then IR sensor will send the status to Raspberry PI
- Raspberry pi will send the message to cloud web app and LcD Display
- The authorized person observe the web app output

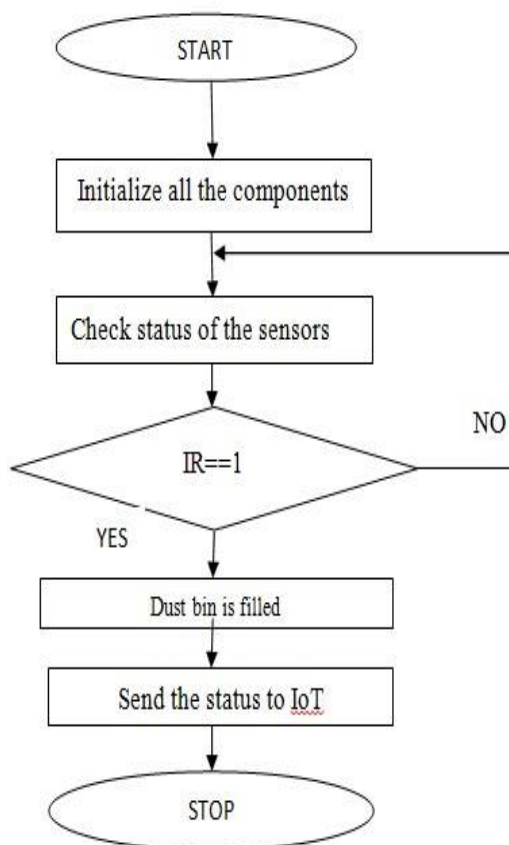



International Journal of Advanced Research in Electrical, Electronics and Instrumentation Engineering

(An UGC Approved Journal)

Website: www.ijareeie.com

Vol. 6, Issue 8, August 2017

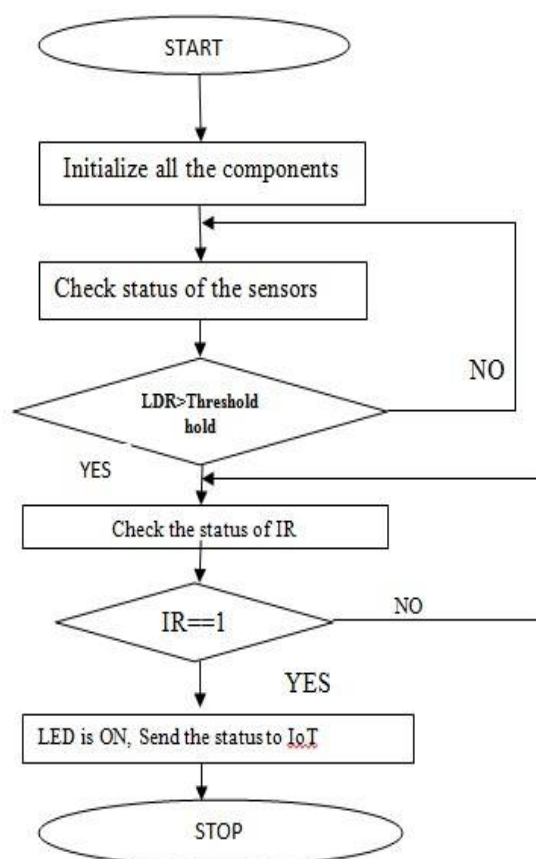

Figure 2(a) and (b): Garbage monitoring system and Automatic street light control

For automatic street light control

- Initializing the system
- check LDR sensor status hold the threshold till $IR==1$
- if $IR==1$ turn ON the LED “street light”
- if $IR==0$, turn OFF the street light



International Journal of Advanced Research in Electrical, Electronics and Instrumentation Engineering

(An UGC Approved Journal)

Website: www.ijareeie.com

Vol. 6, Issue 8, August 2017

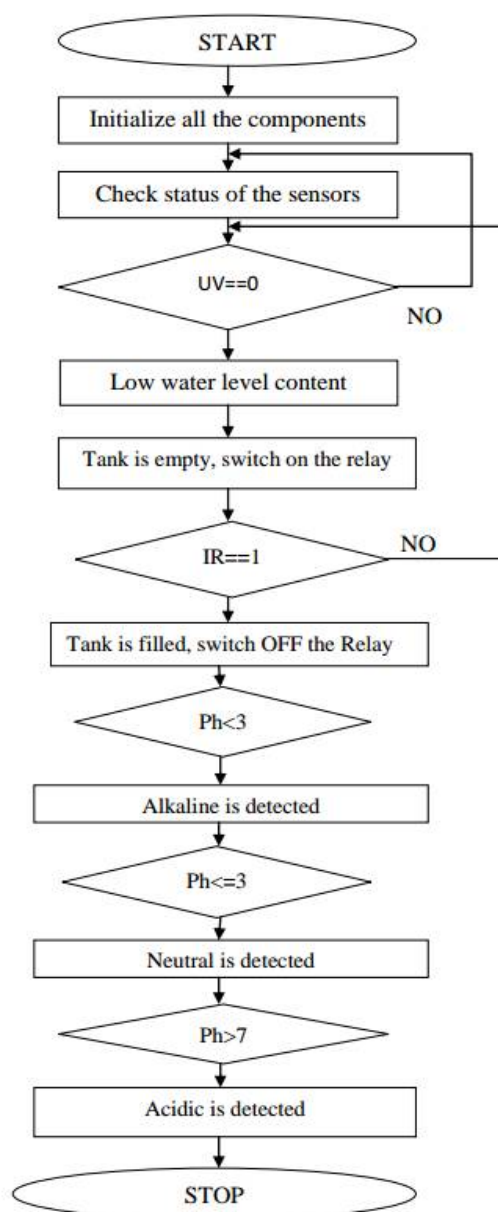

Fig 3:flowchart of automatic water supply and quality of water

(a)Raspberry pi3:The raspberry pi3 model B acts as a controller to which the I/O devices are interfaced. The raspberry pi3 model B has a 40 GPIO pins. a quad core 64-bit Arm-cortex A53 with a clock speed of 1.2GHz .it is 50% faster than the raspberry pi2. It works on the 3.3V

(b)IR sensor:IR sensor is used to detect the object upto 2cm. It consists of IR Led and photodiode.IR led emits the IR radiation which is invisible to human eyes. When the object is detected then the rays is detected by receivers.



ISSN (Print) : 2320 – 3765
ISSN (Online): 2278 – 8875

International Journal of Advanced Research in Electrical, Electronics and Instrumentation Engineering

(An UGC Approved Journal)

Website: www.ijareeie.com

Vol. 6, Issue 8, August 2017

(c)Ultrasonic sensor:Ultrasonic sensor are the sound sensors which measures the distance from 2cm-400cm.it has two pins trigger and Echo these two pins used to calculate the distance of the object. This sensor generates sound waves which calculate the time duration of the echo that is generated.

(d)Light Dependent Resistor (LDR):A Light Dependent Resistor is a device which has a resistance varies according to the amount of light falling on its surface, when light falls upon it then the resistance changes. Raspberry pi3 model B doesn't have analog pins and LDR sensor is an analog sensor so MCP3008 IC is used for converting analog signals to digital signals.

(e)Relays:A relay is an electromechanical device that is trigger by an electrical current. The current flowing in one circuit causes the opening or closing of another circuit. Relays are used in many applications because of their relative simplicity, long life, and proven high reliability. Relays are mainly made for two basic operations. One is low voltage application and the other is high voltage. For low voltage applications, more preference will be given to reduce the noise of the whole circuit. For high voltage applications, they are mainly designed to reduce a phenomenon called arcing.

(f)LCD: Liquid Crystal Display is a electronic display module which is used in many of the applications. The 16*2 display is very commonly used. A 16*2 LCD means 16 characters per line and there are two such lines. It has two registers data and command. These instructions which is displayed on LCD is read by people
A command is an instruction given to the LCD to do a given task and data is a ASCII values of a character to be displayed on the LCD.

(g)pH Sensor:pHsensor is a sensor which measures the quality of a water. It measures of the acidity or alkalinity of a water solution. At 25°C, a neutral solution has a pH of 7.0, while solutions with $\text{pH} < 7$ are acidic and solutions with $\text{pH} > 7$ are alkaline. The normal overall pH range is 0 to 14 pH, although solutions containing non-water solvents can have pH values outside this range.

(h)Power Supply: We use 12v power supply in our project. It is mainly used to provide DC voltage to the components on board. 3.3V for raspberry pi and 5V is required for relay applied from power supply

IV. RESULTS

The figure 5(a) shows the complete module of IoT based smart village as a model for swatch bharat with a web app using raspberry pi. It is the complete module interfaced with raspberry pi.

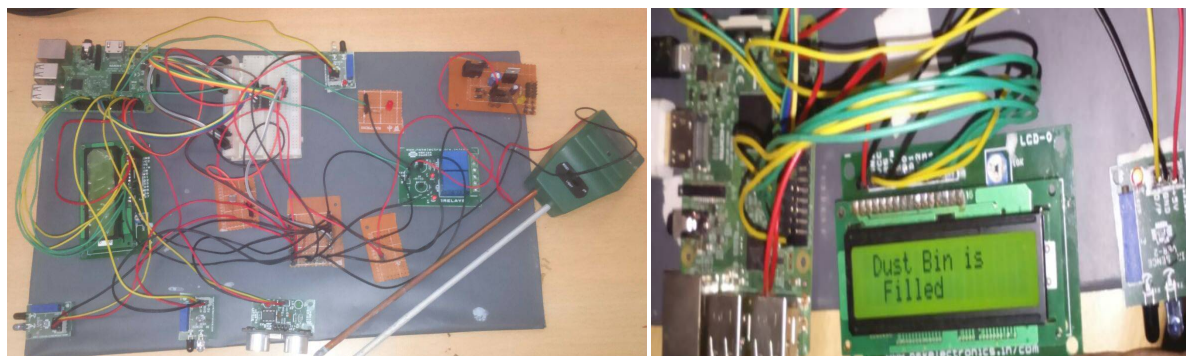

Figure 5(a) and (b): complete module and result of garbage monitoring system

International Journal of Advanced Research in Electrical, Electronics and Instrumentation Engineering

(An UGC Approved Journal)

Website: www.ijareeie.com

Vol. 6, Issue 8, August 2017

Fig 5(b) shows the result of Garbage monitoring system result The waste is detected by the IR Sensor and seen the below result which is displayed on LCD and as well as in the cloud, and as soon as an SMS alert is received, concerned authority can place orders to the workers for cleaning the filled bins on time without allowing them to overflow.

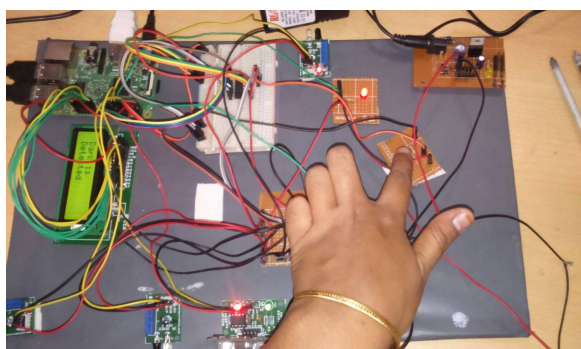

Fig 6: light is on after the obstacle detection

THE fig 6 shows the complete prototype of automatic street light control which includes LDR and IR sensor, show that the street light is getting automatically switched on after detection of the vehicle on the street as well checking the LDR status..

The fig 7(a) shows the complete prototype of checking the quality of water which includes pH sensor, the ph sensor is dipped in the water to check the nature of water and the figure showing that the water is “Neutral”

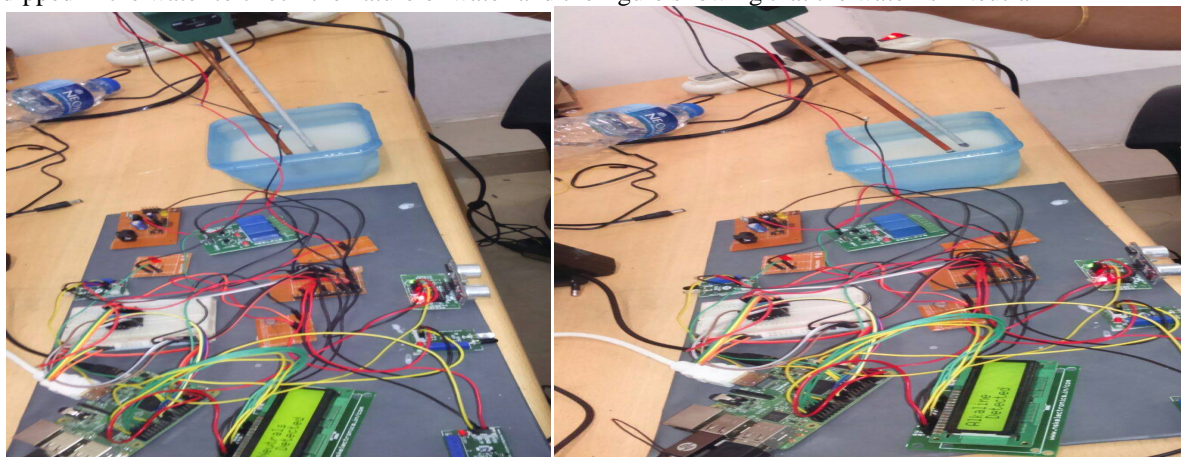

Fig 7(a) and (b): Neutral water and alkaline water is detected

Figure 7(b) showing that the water is “Alkaline” which is displayed on LCD. And webpage which displaying the real time data of the quality of water on the webpage through internet.

The scenarios are updated in the cloud as shown in the below figures.

- The figure shows the graph of garbage monitoring system. When there is logic high the dust is detected



International Journal of Advanced Research in Electrical, Electronics and Instrumentation Engineering

(An UGC Approved Journal)

Website: www.ijareeie.com

Vol. 6, Issue 8, August 2017

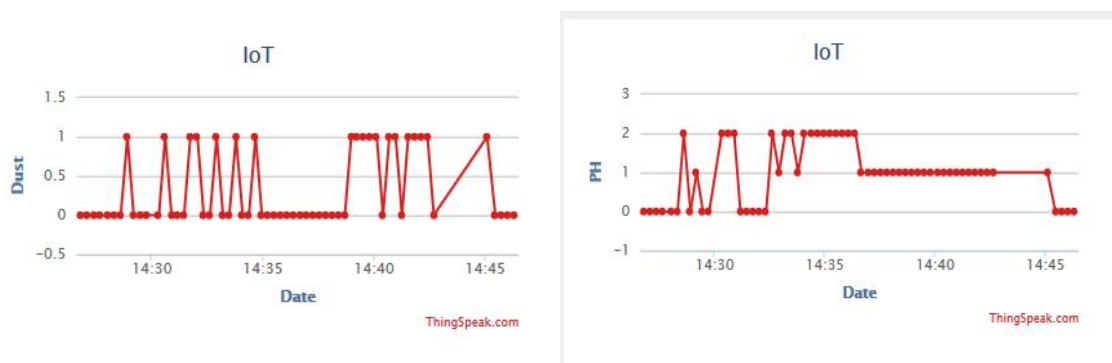

Fig 8(a) and (b): graph dust v/s time of garbage monitoring system and pH v/s date showing quality of water

- The above figure shows the ph level measurement, were 0 intimates that the water is acetic,1 intimates that the water is alkaline and 2 indicates the water is neutral this can be measured for after each and every 16seconds

V.CONCLUSION AND FUTURE SCOPE

Using the proposed system, the model can be made completely automated and hence the objective of is to keep rural/urban area clean and avoid from environmental pollution by garbage monitoring system, and through automatic street light control the manpower and energy can be saved and from automatic water supply the power can be saved and water quality is also checked to keep away from the diseases. Thus, it can be concluded with respect to the result obtained that the proposed prototype can be a better and play a vital role in projects like “swatch bharat” and in making Indian smart and clean. The proposed system can be further modified on different levels of designing and implementation. Many more facilities can be added. Through this model the India can be made smarter like aspects of any village such as Digital Display of the Government Subsidies and offers to farmers, E-learning for the students in schools to digitize the India.

REFERENCES

- [1] Richu Sam Alex, R Narciss Starbell, “Energy Efficient Intelligent Street Lighting System Using ZIGBEE and Sensors”, International Journal of Engineering and Advanced Technology (IJEAT)ISSN: 2249 – 8958, Volume-3, Issue-4, April 2014 .
- [2] Gaikwad Prajakta, Jadhav Kalyani, Machale Snehal ,” SMART GARBAGE COLLECTION SYSTEM IN RESIDENTIAL AREA”, IJRET: International Journal of Research in Engineering and Technology.
- [3] Narayan Sharma, Nirman Singha, Tanmoy Dutta, “Smart Bin Implementation for Smart Cities”, International Journal of Scientific & Engineering Research, Volume 6, Issue 9, September-2011
- [4] Deepanshu Khandelwal, Bijo M Thomas, Kritika Mehndiratta, Nitin Kumar “Sensor Based Automatic Street Lighting system” International Journal of Education and Science Research Review Volume-2, Issue-2 April- 2015
- [5] Daichi Amagata, Yuya Sasaki, Takahiro Hara, Shojiro Nishio, “A Robust Routing Method for Top-k Queries in Mobile Ad Hoc Networks” , IEEE 14th International Conference on Mobile Data Management, 2013