



# **Smart Electronic Notice Board and Attendance Monitoring Using ZigBee**

Dr.D.Mohana Geetha<sup>1</sup>, M.Vishali<sup>2</sup>, M.Visali<sup>3</sup>, P.Divya lakshmi<sup>4</sup>

Professor, Dept. of ECE, S.A Engineering College, Chennai, India<sup>1</sup>

UG Student, Dept. of ECE, S.A Engineering College, Chennai, India<sup>2</sup>

UG Student, Dept. of ECE, S.A Engineering College, Chennai, India<sup>3</sup>

UG Student, Dept. of ECE, S.A Engineering College, Chennai, India<sup>4</sup>

**ABSTRACT:** This project deals with a wireless digital noticing system to provide information in a smart way. The Proposed notice board is a Bluetooth based system with a LCD as output. The information transfer between the user and the LCD display is done via Bluetooth, so any notice can be displayed on the electronic board from the user's android mobile using a application named blueterm2.. In addition, the user also can print the information. The total system is designed with simple logic and fabricated with PIC16F877A, LCD, BLUETOOTH, ZIGBEE module and other commercially available electronic devices which can be used effeciently .A smart notice Board is a placed at the receiver side where information sent from the authenticated user is received. In addition to this attendance monitoring is done using finger vein which is implemented in Matlab. This project is very reliable and it is of very less cost. The components involved do not need any complex operation. It is very easy to implement

**KEYWORDS:** Bluetooth; LCD; ZigBee; Matlab

## **I.INTRODUCTION**

A notice board is used to display all the relevant information that is given by the authenticated user. Traditional notice board includes the addition and removal of paper messages. This proposed system eliminates all the disadvantages of traditional method. This is a smart notice board where information is given from a smart phone with an android application named blueterm2.The information is processed in the microcontroller and then displayed in the LCD. ZigBee is used where the master can be connected to multiple slaves. Authentication can be ensured by including special characters in the starting and ending of the information.UART is used to convert the data serially. Additionally attendance monitoring is done using finger vein. The proposed notice board can be used in schools and colleges where it eliminates the traditional method of paper usage. Attendance monitoring is done using finger vein which is implemented in the Matlabsoftware. This overcomes all the drawbacks from the previous systems.

## **II.SYSTEM DESCRIPTION**

Figure 1 shows the block diagram of the proposed system. Here the information from the mobile is sent to the microcontroller using an android app called blueterm2. Then the data is sent to the receiver side via ZigBee. At the same time attendance can be monitored using the finger vein which is implemented using the Matlab software.

# International Journal of Advanced Research in Electrical, Electronics and Instrumentation Engineering

(An ISO 3297: 2007 Certified Organization)

Vol. 5, Issue 3, March 2016

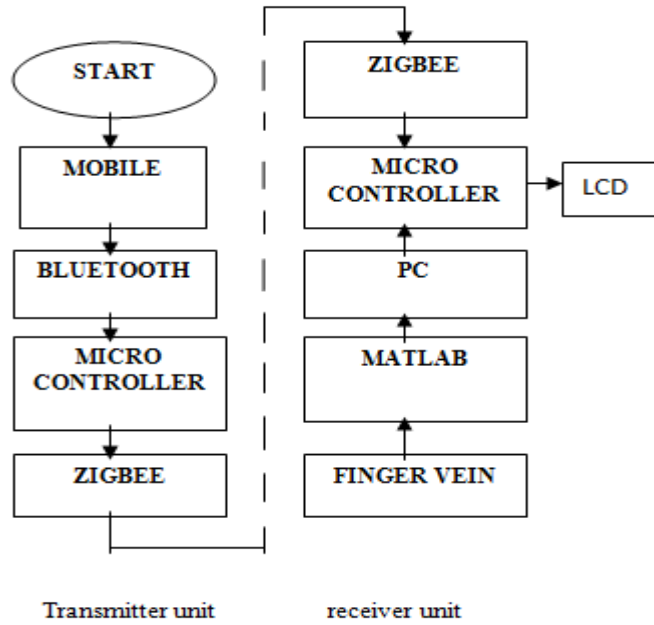

Figure 1: block diagram of the system

This is a multiuser system so that anyone who is authorized can give the input within some special characters which can replace the passwords.

### III.SYSTEM CIRCUIT DIAGRAM

Figure2 depicts the transmitter side of the system. Bluetooth is used to connect the mobile phone and the microcontroller. The information is transmitted to the transmitter side via ZigBee. Bluetooth and ZigBee are interfaced to PIC16F877A in the transmitter side. Bluetooth is interfaced to the RXD pin and ZigBee is connected to the TXD pin.

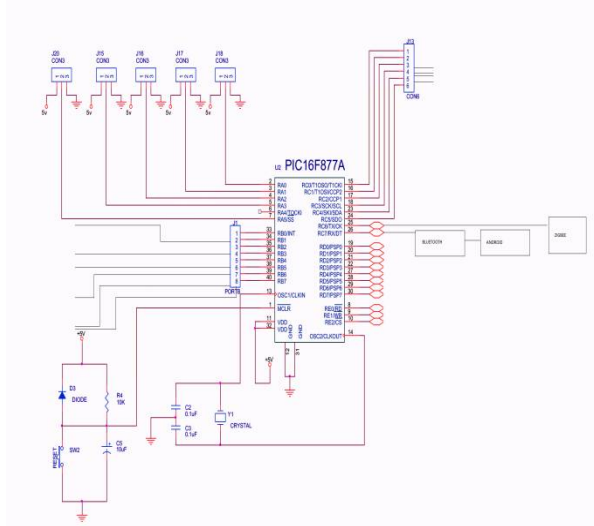

Figure2. Transmitter side of the circuit

# International Journal of Advanced Research in Electrical, Electronics and Instrumentation Engineering

(An ISO 3297: 2007 Certified Organization)

Vol. 5, Issue 3, March 2016

PIC16F877A is the central processing system of the system. A Crystal is connected between pin 13 and 14. A power supply of 5v is given to all the component.

## IV.HARDWARE DESCRIPTION

### A. Central Processing

The PIC16F877A is 40 pin chip with 256 bytes of EEPROM data memory, self programming ,an ICD, 2 comparators ,8 channels of 10 bit A/D converter. The synchronous serial port can be configured as either 3-wire serial peripheral interface or the two wire integrated circuit bus and a universal asynchronous receiver transmitter (USART).PORTA is a bidirectional port. The respective data direction register is TRISA. fixing a TRISA bit (= 1) will make the respective PORTA pin as input (i.e., put the respective output driver in a High-Impedance mode). Clearing a TRISA bit (= 0) will make the respective PORTA pin an output (i.e.,input the contents of the output latch on the choosed pin). On examining the PORTA register exams the status of the pins andthen it writes it to the port latch. every write operation is a read-modify-write operations. hence, a write to a port depicts that the port pins are examined and the value is changed and then written to the port data latch.

### PORTB and the TRISB Register

PORTB is an 8-bit width, bidirectional port. The respective data direction register is TRISB. fixing a TRISB bit (= 1) will make the respective PORTB pin an input (i.e., put the respective output driver in a High-Impedance mode). erasing a TRISB bit (= 0) will make the respective PORTB pin an output (i.e., input the contents of the output latch on the selected pin). These three pins of PORTB are multiplexed with the In-Circuit Debugger and Low-Voltage Programming function: RB3/PGM, RB6/PGC and RB7/PGD. . A single control bit can make all the pull-ups on.

### PORTC and the TRISC Register:

PORTC is bidirectional port . The data register is TRISC. fixing a TRISC bit (= 1) will make the respective PORTC pin an input (i.e., put the respective output driver in a High-Impedance mode). Clearing a TRISC bit (= 0) will make the respective PORTC pin an output (i.e., put the contents of the output latch on the selected pin). PORTC is multiplexed with many peripheral functions

### PORTD and TRISD Registers:

PORTD is an 8-bit port .it has Schmitt Trigger input buffers. Each pin is seperatelyconfigurable as an input pin or output pin. PORTD can be made as an 8-bit wide microprocessor port byfixing control bit, PSPMODE . In this corresponding mode, TTL is made as the input buffer

### PORTE and TRISE Register:

PORTE has specific pins (RE0/RD/AN5, RE1/WR/AN6 and RE2/CS/AN7) which are seperately configured as input pins or output pins. These pins have Schmitt Trigger input buffers. The PORTE pins are made as the I/O control inputs for the microprocessor port when bit PSPMODE is set up. In this mode, the user can set the bits and that the pins are made as digital inputs.

### B.Power Supply

A Single phase AC power supply of 230v and 50hz is given as a input to a step down transformer to get 12v supply. This voltage is changed to DC voltage using a Bridge Rectifier. The converted pulsating DC voltage is filtered by a 2200uf capacitor and then given to 7805 voltage regulator to get a constant 5v supply. This 5v supply is given to all the components in the circuit.

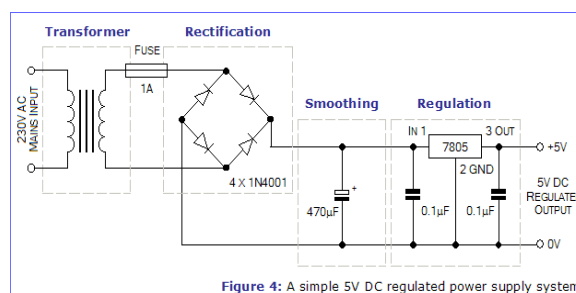

Figure 4: A simple 5V DC regulated power supply system

Figure3. Power supply unit

## C. zigbee

ZigBee is a specification that suits high level communication protocols using small, low-power digital radios based on the IEEE 802.15.4 standard for WPAN (LR-WPANs), such as wireless switch with lamps, electrical meters with in-home-displays, consumer electronics equipment through short-range radio needing low rates of data transfer. The technology defined by the ZigBee specification is very simple and not very expensive than other WPANs, such as Bluetooth. ZigBee is aimed at radio-frequency (RF) applications that require a low data rate, long battery life, and secure networking. ZigBee is a of low cost and power. It has a wireless mesh standard. The low cost allows the technology to be largely deployed in wireless control and monitoring applications. The longer life with smaller batteries in ensured with low power supply

## E. Bluetooth

Bluetooth is a wireless method used for exchanging data over short distances (using short-wavelength radio transmissions ) from mobile devices, creating personal area networks (PANs) with high range of security to other respective devices. It was discovered by telecoms vendor Ericsson in 1994. it is used as a wireless alternative to RS-232 data cables. It can connect several devices to overcome the problem of synchronisation.

## V.SOFTWARE DESCRIPTION

Matlab software is used to process the finger vein data. The is processed in the controller and displayed in the LCD. The finger vein data is given as a gray scale image. Image processing done here is DWT (discrete wavelet transform).DWT reduces the complexity and the edges can be easily detected.

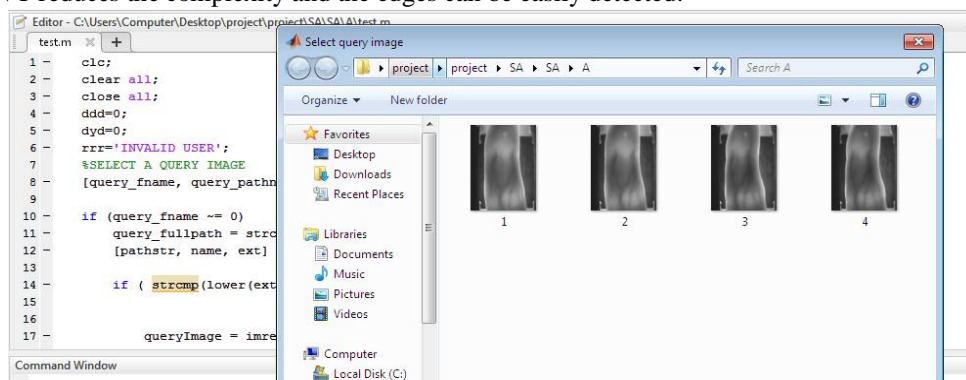

Figure4. Selection of query image

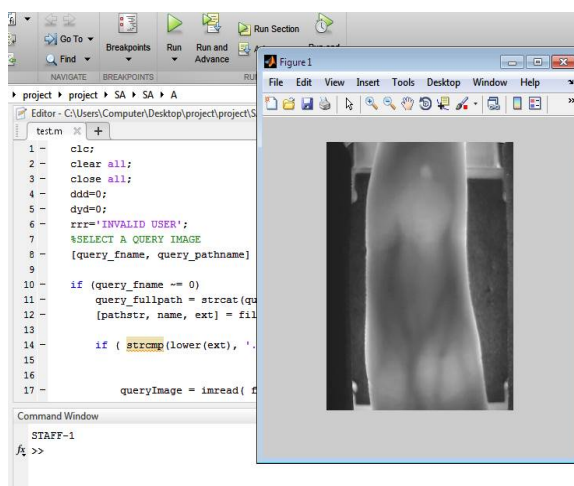

Figure 5. MATLAB output



ISSN (Print) : 2320 – 3765  
ISSN (Online): 2278 – 8875

# International Journal of Advanced Research in Electrical, Electronics and Instrumentation Engineering

(An ISO 3297: 2007 Certified Organization)

Vol. 5, Issue 3, March 2016

In real-time this can be processed in a finger vein module with a camera instead of offline data. Finally the output is processed in the microcontroller and displayed in the LCD. A discrete wavelet transform is a wavelet transform where it samples the wavelets discretely. The main advantage of DWT is that it captures both the frequency and location information

## REFERENCES

- [1]. Adewole k. s., Abdulsalam s. o., Babatunde r. s, Shittu t. m. and Oloyedem. "Development of fingerprint biometric attendance system for non-academic staff in a tertiary institution" Vol.5, No.2, November 2014.
- [2]. Mason Khan, Pratik bhosale, Sandeshdalvi "wireless electronic notice board using gsm technology" volume 3 issue v, may 2015.
- [3]. k.jaikumar, m.santhosh Kumar, s.rajkumar, a.sakthivel "fingerprint based student attendance system with sms alert to parents" volume: 2 issue: 1 124 – 127, Feb 2015.
- [4]. Pushpa S. Gagare., Priyanka A. Sathe, Vedant T. Pawaskar., Sagar S. Bhave "Smart Attendance System" Volume: 2 Issue: 1 124 – 127 January 2014.
- [5]. Gowtham.R, Kavipriya.K, Kesavaraj.G, Natheena.A, Mr. S.Maragatharaj "Multiuser Short Message Service Based Wireless Electronic Notice Board" Volume 2 Issue 4 April, 2013.
- [6]. Pawan Kumar, VikasBhardwaj, Kiran Pal, Narayan Singh Rathor, Amit Mishra, "GSM based e-Notice Board" , International Journal of Soft Computing and Engineering (IJSCE) ISSN.
- [7]. M.Baby, P.Harini, Yelena, Slessor, Y.Tejaswi, K.Ramajyothi, M.Sailaja, K.AnnieSumantha " SMS Based Wireless E-Notice Board System" Certified Journal, Volume 3, Issue 3, March 2013.
- [8]. ] Sung-ho Kim, Hong-Jin Lee, Han-Wool Jung, Beom-Ki Maeng, and Yongsu Park, "IPAP: Improved privacy and authentication protocol for passive RFID tags," Network Infrastructure and Digital Content, 2010 2nd IEEE International Conference on , pp.30-34, 24-26 Sept. 2010
- [9]. Vishal Bhalla, TapodhanSingla, AnkitGahlot and Vijay Gupta, "Bluetooth Based Attendance Management System", International Journal of Innovations in Engineering and Technology (JIET) Vol. 3 Issue 1 October 2013
- [10]. S.-H. Geng, G.-M. Li, and W. Liu, "Design and Implement of Attendance Management System Based on Contactless Smart IC Card," in Proc. International Conference on Computer Science and Electronics Engineering (ICCSEE), vol. 3, pp. 290-294, 23-25 March 2012,
- [11]. M. Mattam, S. R. M. Karumuri, and S. R. Meda, "Architecture for Automated Student Attendance," in Proc. IEEE Fourth International Conference on Technology for Education (T4E 2012), pp.164-167, 18- 20 July 2012
- [12]. Rajasekar, S. Vivek "Wireless Fingerprint Attendance System using ZigBee Technology" International Journal of Power Control Signal and Computation (IJCSC), Vol3. No1. Jan-Mar 2012.
- [13]. M. Kassim, H. Mazlan, N. Zaini, and M.K. Salleh, "Web-based student attendance system using RFID technology, June 2012
- [14]. Agamanolis.S, "Digital displays for human connect endless". In public and situated display Social and international aspects of shared display technology
- [15]. Herman Chung- HwaRao, Di-Fa Chang and Yi-Bing Lin, "iSMS: An Integration Platform for Short Message Service and IP Networks", IEEE Network, pp.48-56, March/April (2001).
- [16]. Jeff Brown, Bill Shipman and Ron Vetter, "SMS: The Short Message Service", IEEE Computer Society, pp.106-111, December (2007)
- [17]. QianXu, Evan Wei Xiang, Qiang Yang, Jiachun Du, JiepingZhong, Agamanolis.S "SMS Spam Detection Using Noncontent Features", IEEE Computer Society, pp.44- 51, (2012).
- [18]. S. K. Jain, U. Joshi, and B. K. Sharma, "Attendance Management System," Masters Project Report, Rajasthan Technical University, Kota.