



# **Maximum Power Point Tracking Algorithms Applied to Wind-Solar Hybrid System**

**T.Arun Kumar, Prof. G.V.Marutheswar**

PG Student[power systems], Dept. of EEE, S.V. University, Tirupati, Andhra Pradesh-517502, India,  
Professor, Dept. of EEE, S.V. University, Tirupati, Andhra Pradesh-517502, India

**ABSTRACT:** The production of electricity from renewable energy sources like solar, wind energy increases in recent years due to environmental problems and the shortage of traditional energy sources in the near future. This paper presents modeling, simulation, and performance study of Hybrid generation system with PI and MPPT controller. The Wind power generation system uses Wind Turbine(WT), a Permanent Magnet Synchronous Generator(PMSG), a three phase controlled rectifier bridge with PI controller, a dc bus with a capacitor and a current regulated PWM voltage source inverter. The PV cell model is developed including the effects of changing solar irradiation and temperature and Maximum power from PV cell is obtained by using MPPT controller. This paper reports the development of wind/photovoltaic power generation system and also describes the Wind-Solar Hybrid system for supplying electricity to the Load and describe various MPPT techniques namely Perturb and Observe(P&O), Incremental Conductance(INC) and Fuzzy Logic based MPPT controller and their performance. Simulation results of Hybrid system using various MPPT techniques are provided.

**KEYWORDS:** Wind power generation system, Solar PV system, PI controller, MPPT Techniques.

## **I. INTRODUCTION**

Without a doubt renewable energy systems present unique[1] opportunities for greater fuel diversity, security and geographical dispersion of supply. The rapid pace of the technical and commercial development of renewable energies continues to reduce costs and increase the number of both equipment suppliers and plant operators. As conventional fossil-fuel energy sources diminish and world's environmental concern about acid deposition and global warming increases, renewable energy sources (solar, wind, tidal and geothermal, etc.) are attracting more attention as alternative energy sources. Among the renewable energy sources wind and solar photovoltaic(PV) energy has been widely utilized in[1] small-sized applications. It is also the most promising candidate for research and development for large-scale uses as the fabrication of loss-costly photovoltaic devices becomes a reality. The wind energy has been considered as one of the significant renewable energy sources in recent years. Wind energy can be [2]transformed to electric energy using a wind turbine and an electric generator. In wind-energy production application of PMSG has received much attention compared to other electric generators, because of its property of self-exciting, which allows an operation at a high power factor and efficiency with the development in permanent magnetic materials in recent years, the performance of PMSG based wind turbine systems has been improved and they are widely used. They can also operate in a relatively wide range of wind speeds. The PV array power and current characteristics are highly nonlinear [3]and are affected by the irradiance and temperature variation. Therefore, a maximum power-point tracker(MPPT) is required to handle such problems and ensure that PV system is operating at the maximum power point(MPP). The existing techniques vary in simplicity, accuracy, time response, popularity, cost and other technical aspect.

The voltage base MPP tracking method uses the fact that ratio between the maximum power voltage and the open circuit voltage under different weather conditions, are[3] linearly proportional. The MPPT techniques like Perturb and Observe(P&O), Incremental conductance and Fuzzy Logic Controller are widely using for tracking maximum power. Among the MPPT methods, hill climbing/P&O are the commonly used algorithms because of simplicity, ease of implementation, and low cost. Hill climbing works by perturbing the PV array system by changing the power converter duty cycle and observing its impact on the PV array output power, and then deciding the new direction of the duty cycle to extract maximum power. The incremental conductive method is widely used because of implementation simplicity and high tracking efficiency. The method is based on the derivative of [3]power over voltage being zero at

# International Journal of Advanced Research in Electrical, Electronics and Instrumentation Engineering

(An ISO 3297: 2007 Certified Organization)

Vol. 4, Issue 10, October 2015

the MPP, positive on the left of the MPP, and negative on the right. Complex computation is required to give good performance under rapidly varying weather conditions. Moreover, the tracking time is relatively long since the step size is turned to be small enough to reach the desired MPP. The Fuzzy-Logic Controller(FLC) has been introduced [3] to evaluate P&O or hill-climbing algorithm drawbacks. In this paper a PV-Wind hybrid system is presented that can supply electricity to a load. The aim of this study is to introduce the local PV-Wind hybrid system is connected to the load. In this paper a detailed dynamic model, control and simulation of PV/WT hybrid power generation system is proposed. Modeling and simulation are implemented using MATLAB/SIMULINK and Simpower system software packages to verify the effectiveness of the proposed system.

## II. WIND TURBINE CHARACTERISTICS AND MODELLING

In order capture the maximal wind energy, it is necessary to install the power electronic devices between WTG and the load where the frequency is constant. The input of a wind turbine is the wind and the output is the mechanical power turning the generator rotor. The block diagram of the load connected wind based system driven by PMSG[7] as shown in Fig.1

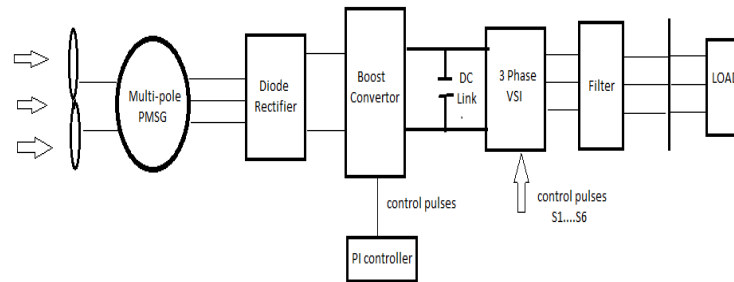

Fig.1 The block diagram of wind energy system

For a variable speed wind turbine, the output mechanical power available from a end turbine could be expressed as[3]

$$P = 0.5\rho AC_p(\lambda, \beta)V_w^3 \quad (1)$$

Where P = power in watt,  $\rho$  = air density, A = rotor swept area,  $V_w$  = wind speed in m/sec,  $C_p$  = coefficient of performance. The relation between rotor speed and [3]wind speed can be given by

$$\lambda = \omega m R / V_w \quad (2)$$

Where R = rotor radius,  $\omega m$  = rotor speed in rad/sec,  $\lambda$  = tip speed ratio(TSR) = ratio [3]between the linear speed of the tip of the blade with respect to the wind speed. The wind turbine torque on the shaft can be calculated from the power

$$T_m = P_m / \omega_m = 0.5\rho\pi R^5 (\omega_m / \lambda)^3 C_p(\lambda, \beta) \quad (3)$$

$$C_p(\lambda, \beta) = 0.5176 \left( \frac{116}{\lambda_i} - 0.4\beta - 5 \right) e^{-(21/\lambda_i)} \quad (4)$$

$$\text{Where, } \lambda_i = [1/(\lambda + 0.08\beta) - 0.035/(\beta^3 + 1)]^{-1} \quad (5)$$

Where  $C_p(\alpha, \beta)$  – performance coefficient of the turbine,  $\omega$  - turbine [3]angular velocity(rad/sec),  $\beta$  – Blade pitch angle(deg),  $\lambda$  - Tip speed of the rotor blade tip speed to wind speed. Equation of the wind turbine is given as:

$$T_m - T_e - F * \omega = J d\omega / dt \quad (6)$$

The  $C_p - \lambda$  characteristics for different values of the pitch angle  $\beta$ , are illustrated in Fig.2 for 12m/s

# International Journal of Advanced Research in Electrical, Electronics and Instrumentation Engineering

(An ISO 3297: 2007 Certified Organization)

Vol. 4, Issue 10, October 2015

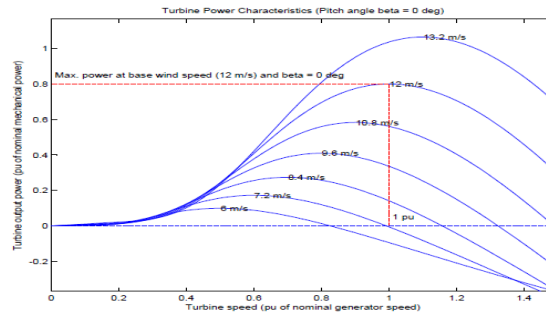

Fig:2- Power coefficient versus Tip Speed Ratio

The maximum value of Cp(Cpmax=0.8) is achieved for  $\beta=0$  and for  $\lambda=1$ . This particular value of  $\lambda$  is defined as the nominal value. The simulated system parameters are listed in the table-1.

Wind Generation specification	
Turbine model	3 blade Horizontal axis
Stator phase resistance	$0.8e^{-3} \text{ kg}\cdot\text{m}^2$
Air density	$\rho = 1.225\text{kg}/\text{m}^3$
Ld, Lq	8.5m/H
Cut in speed of wind	12m/s
Generator parameter	2 MW, PMSG
Generator Frequency	50HZ

Table:-1 Simulation parameters

### III. PV SYSTEM MODEL

A model of photovoltaic cell is shown in Fig.3. From the circuit it can be seen that[4] the current produced by the solar cell is equal to that produced by the current source minus that which flows through the shunt resistor.

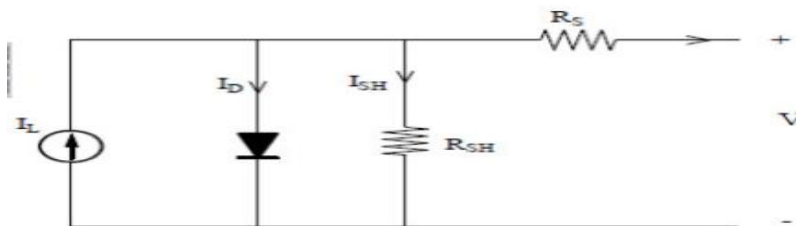

Fig:3- Equivalent circuit of a solar cell

Using the equivalent circuit of a solar cell (Fig:3) and the pertinent equations, the non-linear (I-V) characteristics of a solar cells is given by[4] the following equation:

$$I = I_{ph} - I_0 \left[ \exp\left(\frac{V + IR_s}{V_t}\right) - 1 \right] - \frac{V + IR_s}{R_p} \quad (7)$$

Where 'I' is the PV array output current (A), 'V' is the PV array output voltage (V).

# International Journal of Advanced Research in Electrical, Electronics and Instrumentation Engineering

(An ISO 3297: 2007 Certified Organization)

**Vol. 4, Issue 10, October 2015**

From equation (7) V is given by[4]

$$V = \left( \frac{NsK}{q} \right) \quad (8)$$

Where, Ns is the number of series cell, K is the Boltzmann’s constant in J/K, q is the electric charge. The photocurrent I<sub>ph</sub> depends [4] on the solar radiation and the cell temperature as stated in the following.

$$I_{ph} = (I_{scr} + K_i(T - T_r)) * \left( \frac{G}{G_n} \right) \quad (9)$$

Where I<sub>scr</sub> is the PV array short circuit current at reference temperature and radiation (A), K<sub>i</sub> is the short circuit current temperature coefficient (A/K) and G is the solar radiation (mW/cm<sup>2</sup>). The Fig.4 below gives the characteristics I-V and P-V curve for fixed level of solar irradiation and temperature.

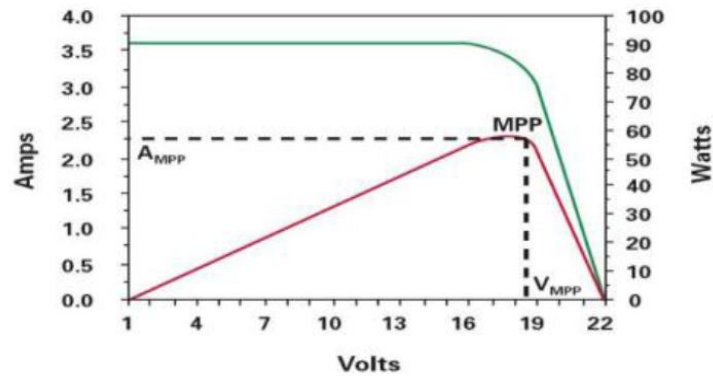

**Fig:4-** PV array characteristics curve

Fig:5 shows Block diagram solar system with MPPT controller.

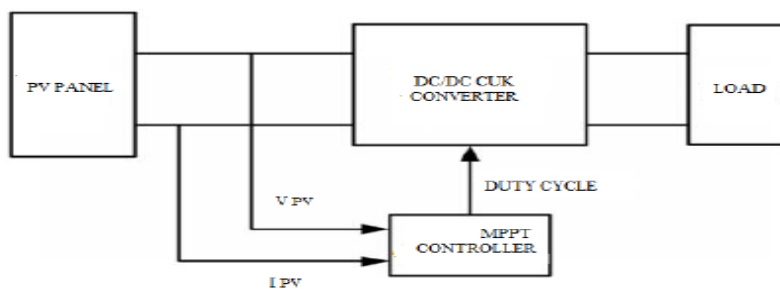

**Fig:5** Block diagram of Solar system

The simulated system parameters are listed in the table 2.

<b>Solar Module specification</b>	
Rating	100KW
SC Current	3.75A
Voltage at peak	21.3V
Open circuit voltage	54.2V
No. cells per module(N <sub>p</sub> )	54

**Table:-2** Simulation parameters

# International Journal of Advanced Research in Electrical, Electronics and Instrumentation Engineering

(An ISO 3297: 2007 Certified Organization)

Vol. 4, Issue 10, October 2015

## IV. MPPT ALGORITHM TECHNIQUES

### A. PERTURB AND OBSERVE METHOD

In this method the controller adjusts the voltage by a small amount from the array and measure power, if the power increases further adjustments in that direction are tried until power no longer increases. This is called perturb and observe [5] method and it is most common, although this method can result in oscillations of power o/p. It is referred to as **hill climbing algorithm method** because it depends on the rise of the curve of power against voltage below maximum power point and the fall above that point perturb and observe is the most commonly used MPPT method due to its ease of implementation. P&O method may result in top level efficiency, provide that a proper predictive and adaptive hill climbing strategy is adopted. The fig.6 shows flowchart for P&O method,

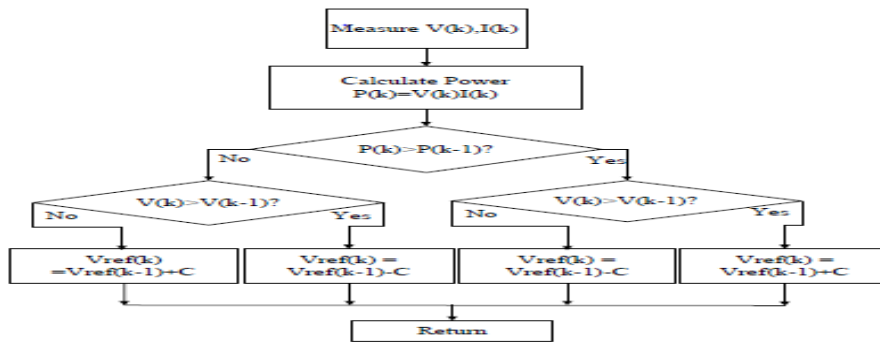

Fig:6 P&O method flow chart

### B. INCREMENTAL CONDUCTANCE ALGORITHM

In the incremental conductance method, the controller measures incremental changes in array current and voltage to predict the effect of a voltage change. This method requires more computation in the controller, but can track changing conditions more rapidly than the perturb and observe method. Like the P&O algorithm, it can produce oscillations in a power o/p. This method utilizes the incremental conductance ( $di/dv$ ) of the PV array to compute the sign of the change in power with respect to voltage ( $dp/dv$ ).

The incremental conductance method computes the maximum power point by comparison of the incremental conductance ( $I\Delta/V\Delta$ ) to the array conductance ( $I/V$ ). When these two are the same ( $I/V = I\Delta/V\Delta$ ), the o/p voltage is the MPP voltage. The controller maintains this voltage until the irradiation changes and the process is repeated. The Fig.7 shows flowchart for incremental conductance method,

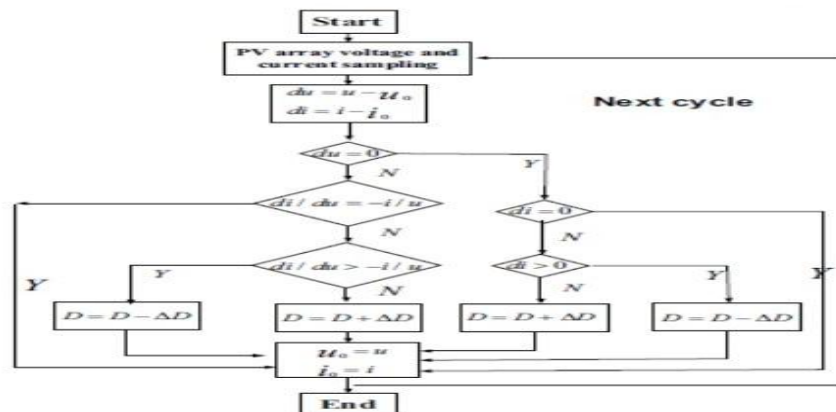

Fig:7 Incremental conductance method flow chart

# International Journal of Advanced Research in Electrical, Electronics and Instrumentation Engineering

(An ISO 3297: 2007 Certified Organization)

Vol. 4, Issue 10, October 2015

## C. Fuzzy Logic Control Algorithm

Since the PV array exhibits a non-linear current-voltage (or) power-voltage characteristics, its maximum power point varies with [6]the insulation and temperature. By the knowledge based fuzzy rules, fuzzy control can track maximum power point. The disadvantage of this control is the high cost of implementation owing to complex algorithms that usually need a DSP as their computing platform. Fig:8 shows PV system with FUZZY MPPT controller.

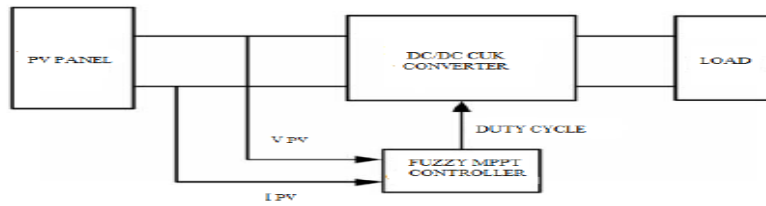

Fig:8-Block diagram of PV system with FUZZY MPPT

We choose to use the fuzzy logic controller method as MPPT instead of P&O, INC, because by doing so there is a reduction not only in the time required to track the MPP but also in the fluctuation of power. The below table-3 shows fuzzy rules[6] for maximum power point algorithm

	NB	NS	PS	PB
NB	PB	PB	NB	NB
NS	PS	PS	NS	NS
PS	NS	NS	PS	PS
PB	NB	NB	PB	PB

Table:3 Fuzzy Logic Rules

Table.3 shows the rule table of the fuzzy controller where all the entries of the matrix are fuzzy sets of change of power and change of current and duty ratio D to the boost converter. The variable inputs and outputs are divided into four fuzzy subsets: PB(Positive Big), PS(Positive Small), NB(Negative Big), NS(Negative Small). Therefore, the fuzzy algorithm requires 16 fuzzy control rules. Fig.9 shows a block diagram of the MPPT structure.

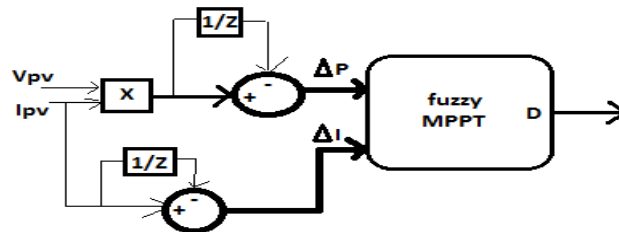

Fig:9 Block diagram of the FLC based MPPT

After simulating the PV system and studying the behavior of the controller inputs and output, the shapes and fuzzy subset partitions of the membership function in both of inputs and output are shown in Fig.10 .

# International Journal of Advanced Research in Electrical, Electronics and Instrumentation Engineering

(An ISO 3297: 2007 Certified Organization)

Vol. 4, Issue 10, October 2015

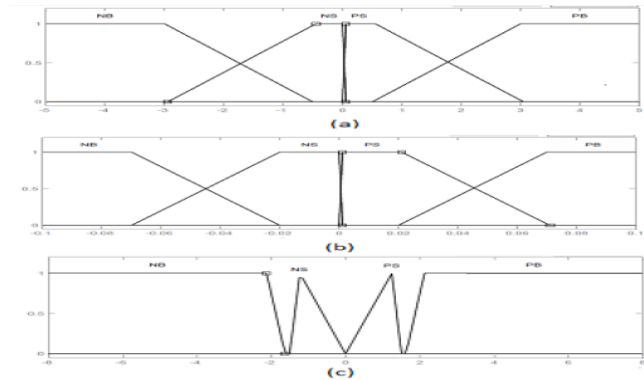

Fig:10- Membership functions: (a) input  $\Delta P$ , (b) input  $\Delta I$  (c) Output  $\Delta D$ .

## D. Comparison Of MPPT Algorithms

- Both P&O and Incremental conductance are examples of “Hill climbing” methods that can find the local maximum of the power curve for the operating condition of the array and so provide a true MPP.
- The P&O method can produce oscillations of power output around the MPP under steady state illumination.
- The Incremental conductance method has advantage over the P&O method that can determine the maximum power point without oscillating around this value. It can perform MPPT under rapidly varying irradiation conditions with higher accuracy than the P&O method.
- The Fuzzy logic control based method has high accuracy than P&O and INC methods.
- The computational time is increased due to slowing down of the sampling frequency resulting from the higher complexity of the algorithm compared to the P&O and INC method.

## V. PV-WIND HYBRID SYSTEM

A hybrid energy system usually consisting of two or more renewable energy sources are used together to provide increased system efficiency as well as greater balance in energy supply. In this paper, the hybrid energy system is a photovoltaic array coupled with a wind turbine. Fig:11 shows the schematic diagram of hybrid system. The developed system consists of 100KW photovoltaic array and 100KW PMSG based wind turbine connected to the load for achieving maximum power point with a current reference control produced by MPPT algorithms.

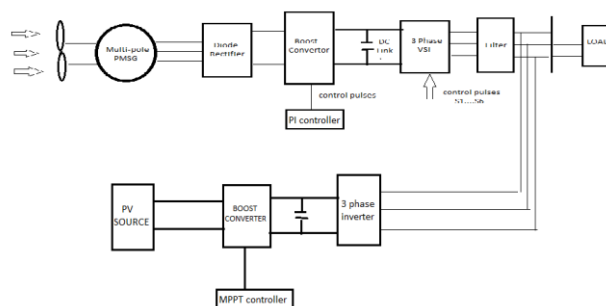

Fig:11 Block diagram of Hybrid system

## VI. SIMULATION MODELS AND RESULTS

In Fig.12 the wind turbine is designed according to the wind characteristic equation. The wind turbine output power is given into the PMSG. The purpose of this circuit is to control the shaft speed of the PMSG so that the maximum power can be captured from wind by the turbine.

# International Journal of Advanced Research in Electrical, Electronics and Instrumentation Engineering

(An ISO 3297: 2007 Certified Organization)

Vol. 4, Issue 10, October 2015

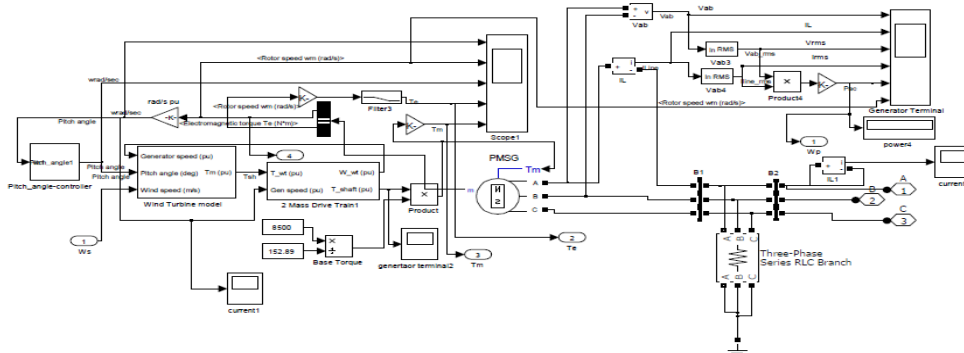

Fig:12 simulation model for wind turbine

In Fig.13 the PV system is designed according to the characteristic equations and simulation model for PV system as shown in Fig.13. In this system the PV cells are connected in parallel and it gives current as output from the PV array and is applied to DC-DC boost converter.

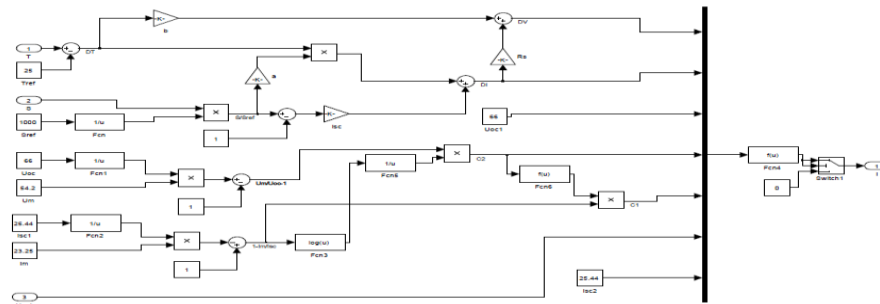

Fig:13 Simulation model for PV system

Fig.14 shows simulation model for perturb and observe algorithm. The present power  $P(k)$  is calculated with the present values of PV voltage  $V(k)$  and current  $I(k)$ , and is compared with the previous  $P(k-1)$ . If the power increases, keep the next voltage change in the same direction as the previous change. Otherwise, change the voltage in the opposite direction of the previous one.

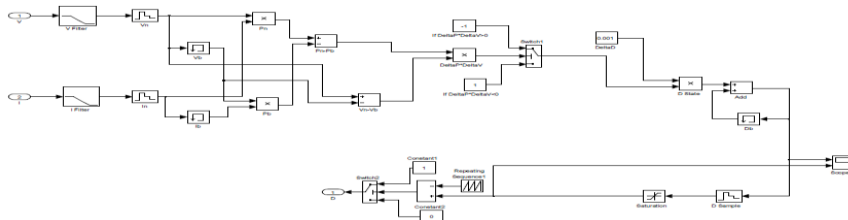

Fig:14 Simulation model for P&O Algorithm

The PV output power is used to directly control the power converter duty cycle to reduce well the complexity of the system. The simulation model for Incremental conductance Algorithm as shown in Fig.15, where the converter duty cycle is generated.



# International Journal of Advanced Research in Electrical, Electronics and Instrumentation Engineering

(An ISO 3297: 2007 Certified Organization)

Vol. 4, Issue 10, October 2015

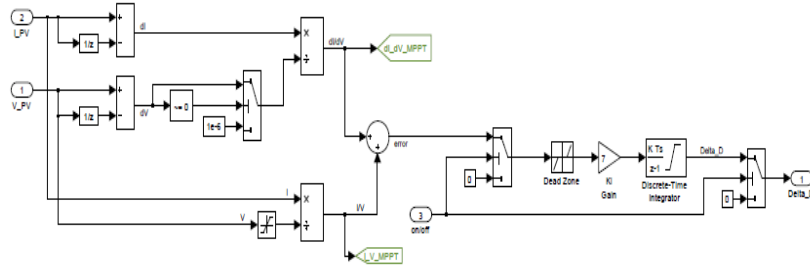

**Fig:15** Simulation model for INC Algorithm

The simulink model of the entire Wind energy conversion system is shown in Fig.16. It consists of three major blocks: wind turbine and PMSG, rectifier and inverter block. In this system the power generated by using 12m/s wind speed. The boost converter is operated based on duty cycles and these duty cycles are generated by Proportional and Integral(P&I) controller.

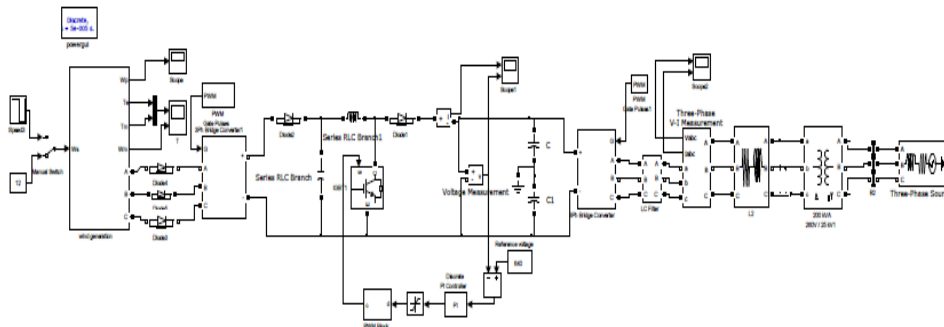

**Fig:16** Simulink model of entire WECS

The simulink model of the entire PV system as shown in Fig.17. In this system the MPP tracked by using MPPT controller and it has inputs voltage and current and generate duty cycle to the DC-DC Boost converter, and this DC voltage convert into three phase AC voltage by using voltage source inverter.

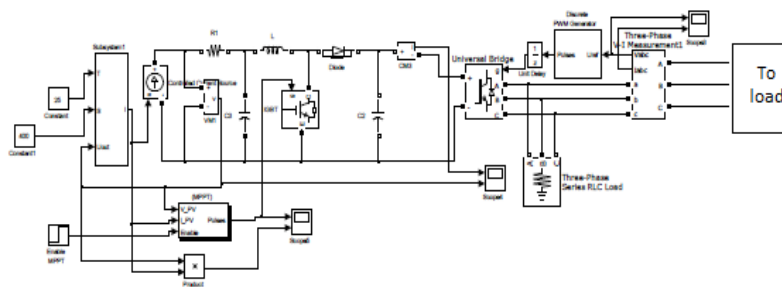

**Fig:17** Simulink model of PV system

# International Journal of Advanced Research in Electrical, Electronics and Instrumentation Engineering

(An ISO 3297: 2007 Certified Organization)

Vol. 4, Issue 10, October 2015

The proposed simulation representation is shown in Fig.18, and it is a combination of wind energy conversion system and solar PV system and is used to control the power supply to the load. In wind energy conversion system the DC-DC boost converter operated by PI controller and in solar PV system the DC-DC boost converter operated by MPPT controller.

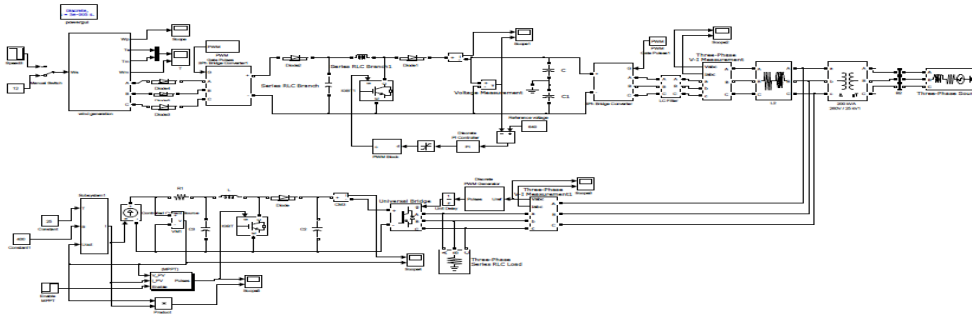

**Fig.18** SIMULINK model of wind-solar hybrid system

The Fig.19 shows PMSG Phase current and Phase voltage and Inverter Phase current and Phase voltage.

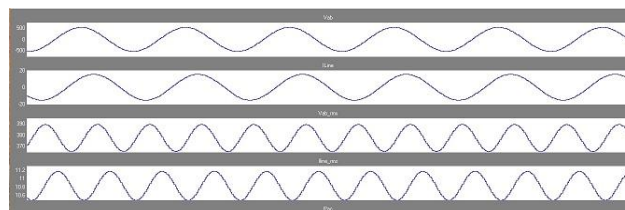

**Fig.19** shows Simulation results for wind speed 12m/s.

**Fig.20** illustrates the time domain simulated results for wind speed 12m/s and reference turbine speed  $\omega_{ref}$

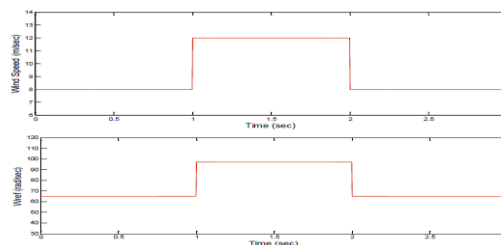

**Fig. 20.** Simulated results– wind speed and reference turbine speed  $\omega_{ref}$ .

The Fig.21 shows duty cycle variations are fed into the boost converter.

# International Journal of Advanced Research in Electrical, Electronics and Instrumentation Engineering

(An ISO 3297: 2007 Certified Organization)

Vol. 4, Issue 10, October 2015

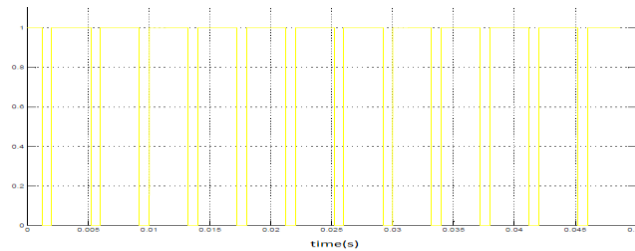

**Fig:21** Duty cycle fed to the boost converter

Fig.22 shows I-V characteristics for different irradiance values.

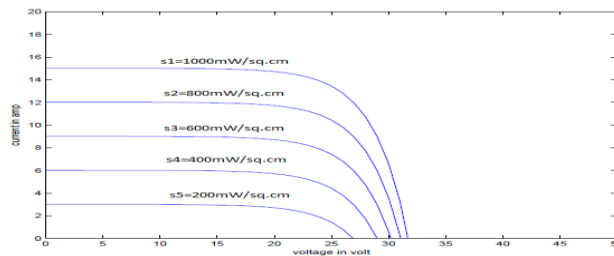

**Fig:22** I-V characteristics of PV cell

Fig.23 shows P-V characteristics for different irradiance values.

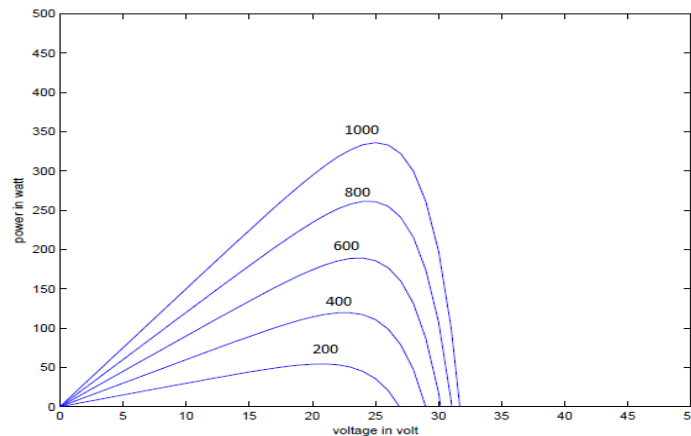

**Fig:23** P-V characteristics of PV cell

The Table.4 shows elapsed time when the PV simulation system is executed with three MPPT methods under three different weather conditions. According to the result shown in Table.4, the elapsed times of the P&O method are the shortest under all conditions. The FLC method has longest elapsed times owing to its more complicated judgment procedure than those of the other two methods.



# International Journal of Advanced Research in Electrical, Electronics and Instrumentation Engineering

(An ISO 3297: 2007 Certified Organization)

Vol. 4, Issue 10, October 2015

Elapsed time of MPPT(s)			
Irradiance	400W/m <sup>2</sup>	600W/m <sup>2</sup>	1000W/m <sup>2</sup>
Temperature	21C	23C	25C
P&O	1.350743	1.66736	1.7038632
INC	1.48879	1.795515	1.8577312
FLC	1.545303	1.875628	1.9110148

**Table:4** Comparison of the elapsed time for different MPPT systems

The overall MPP tracking efficiencies for different MPPT methods during changing conditions as shown in Table.5

Algorithm	MPP Tracking Efficiency (%)
P&O	88.1
INC	92.5
FUZZY	94.6

**Table:5** MPP Tracking Efficiencies of the different MPPT methods

## VII. CONCLUSION

In this paper a hybrid wind-solar PV generation system has been presented. It is observed that the extraction of the maximum power from PV array is obtained using MPPT system. The perturb and observe(P&O), incremental conductance(INC) and Fuzzy logic controller algorithms has been implemented. The proposed system has been simulated in MATLAB-SIMULINK environment. The dynamic behavior of the proposed model is examined under different operating conditions. Solar irradiance, temperature and wind speed data is gathered from wind power generation and solar PV system.

## REFERENCES

- [1] Theodoros L. Kottas, "New Maximum Power Point Tracker For PV Arrays using Fuzzy Controller", *IEEE Transactions On Energy Conversion*, VOL.21, NO.3, SEPT 2006.
- [2] Jayalakshmi N.S., D.N.Gaonkar, "Maximum Power Point Tracking for Grid Integrated Variable Speed Wind based Distributed Generation system with Dynamic Load", *International Journal Of Renewable Energy Research*, Vol.4, No.2, 2014.
- [3] Bader N.Alajmi, Khaled H. Ahmed, Stephen J. Finney, and Barry W. Williams, "Fuzzy Logic Control approach of a modified Hill-Climbing method for Maximum power point in Microgrid standalone Photovoltaic system", *IEEE Transactions On Power Electronics*, Vol.26, No.4, April 2011.
- [4] M.A. Mahmud, H.R .Pota and M.J. Hossain, "Nonlinear Current Control Scheme for a Single-Phase Grid- Connected PV system", *IEEE Transactions On Sustainable Energy*, Vol.5, No.1, Jan 2014.
- [5] Ting-Chung Yu, Yu-Cheng Lin, "A study on maximum power point tracking algorithms for photovoltaic systems", *IEEE Transactions On Industrial Electronics*, Vol.53, No.4, June 2006.
- [6] Bader N. Alajmi, Khaled H. Ahmed,"Single-Phase Single-Stage Transformer less Grid-Connected PV system", *IEEE Transactions On Power Electronics*, Vol.28,No.6 June 2013.
- [7] Monica Chinchilla, Santiago Arnaltes and Juan Carlos Burgos, "Control of Permanent-Magnet Generators Applied to Variable-Speed Wind-Energy Systems Connected to the Grid" *IEEE Transactions On Energy Conversion*, Vol 21, NO, 1, March 2006 Pp. 130-135.
- [8] C.Y Won, D.H. kim, W.S. Kim, " A new maximum power point tracker of PV arrays using Fuzzy Logic Controller", *IEEE 25<sup>th</sup> Annu. Power Electron. Spec. Conf.*, 1994, vol.1, pp. 396-403.
- [9] Ashish Pandey, Nivedita Dasgupta,"High-Performance Alogorithms for Drift Avoidance and Fast Tracking in Solar MPPT System", *IEEE Transaactions On Energy Conversion*, Vol.23, No.2, June 2008.
- [10] Fangrui Liu, Shanxu Duan, " A Variable Step Size Inc Mppt Method For Pv Systems ", *IEEE Transaactions On Industrial Electronics*, Vol.55, No.7 July 2008.