



PSO-based PV integrated with Street Light Optimization Control

Molu Elsa Eapen¹, Ganesh Mahadevan²

PG Student [Power System], Dept. of EEE, Saint Gits College of Engineering, Kottayam, Kerala, India¹

PG Student [Power System], Dept. of EEE, Saint Gits College of Engineering, Kottayam, Kerala, India²

ABSTRACT: Security imposed a major concern at night due to the total darkness over the years. The goal of this research is to make a system that can provide light throughout the night using an optimizing method. According to the available state of charge of the battery, the number of lamps to be illuminated either from photovoltaic system or from the grid is optimized out. During daytime, maximum solar power is tracked by using PSO algorithm for photovoltaic system even under partial shading condition. The whole system is designed so as to provide an adequate power for lighting about 66 street lights throughout the night by using optimization where the available state of charge of the battery is enquired. To evaluate the effectiveness of the proposed method, MATLAB simulations are carried out under challenging conditions. At last, a 5-kW equivalent solar panel has been built and tested to verify the theoretical analysis of the paper.

KEYWORDS: Particle Swarm Optimization (PSO); partial shading; MPPT; MATLAB; Photovoltaic(PV).

I.INTRODUCTION

The power source for street light are still supplied from the grids which are supplied mostly by non-renewable energy sources such as fossil fuels. There are several alternatives of renewable energy source that can be used for street light in public areas. One promising source of renewable energy is the sun which is available throughout. However the price of the sun energy is still high compared to the power from fossil fuels. Solar street lights are beneficial in that the day to day running and maintenance costs are reduced, save energy, environment friendly and convenient to install. Automatic streetlight needs no manual operation of switching ON and OFF. The system itself detects whether there is need for light or not. When darkness rises to a certain level then automatically streetlight is switched ON and when there is other source of light, the streetlight switches OFF. This vital use of light gives rise to the idea of using solar energy to power street lights as an alternative to electricity. These solar-powered street lights can then be used for the provision of illumination on roads at night to enhance security and prevent accidents that may otherwise occur due to poor visibility. At the night time, the lamp starts consuming the electricity stored in the battery and during the daytime, the battery gets recharged.

The objective of this research is to make a system that can provide light throughout the night using an optimizing method. According to the available state of charge of the battery, the number of lamps to be illuminated either from photovoltaic system or from the grid is optimized out. During daytime, maximum solar power is tracked by using PSO algorithm for photovoltaic system even under partial shading condition. Renewable energy is important part of power generation system due to diminution of fossils fuel. Energy production from photovoltaic (PV) is widely accepted as it is clean, available in abundance, & free of cost. The entire system provides an adequate power for lighting about 66 street lights throughout the night by using optimization where the available state of charge of the battery is enquired. Accordingly the lights that can be supplied by panels and from the grid is optimized out. Thus the consumers receive the lights throughout the night economically.

II.SYSTEM MODEL AND ASSUMPTIONS

A PSO based PV system equivalent to 10 panels is created, producing a power of 5kW which is connected to a buck converter which steps down the voltage of 170V to 20V. 20V is required by the battery, though the voltage rating of which is 12V. The battery used here is Lithium ion battery. The charging or discharging of the battery is shown by respective scopes. The battery is followed by the inverter which effectively converts the dc power to ac to be utilized

International Journal of Advanced Research in Electrical, Electronics and Instrumentation Engineering

(An ISO 3297: 2007 Certified Organization)

Vol. 4, Issue 10, October 2015

for the respective purposes. The LCL filter filters out the harmonics to create a sine wave. The filter is followed by step up transformer for stepping up the voltage value to 230V to be utilised by the grid.

The whole system is designed so as to provide an adequate power for lighting about 66 street lights throughout the night by using optimization where the available state of charge of the battery is enquired. Accordingly the lights that can be supplied by panels and from the grid is optimized out. Thus the consumers receive the lights throughout the night i.e. from 7pm to 6am. Time between 12am to 7pm is required for charging PV panels by using an effective PSO-based MPPT.

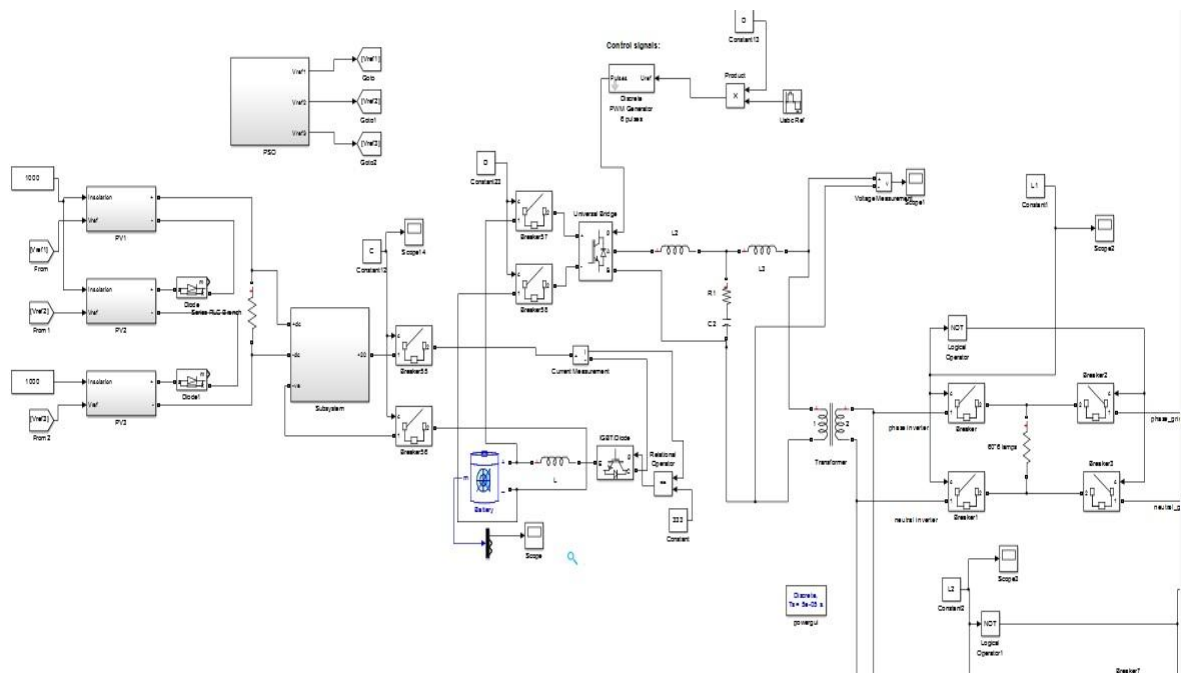

Fig.1 Main SIMULINK Model

III. DESIGNS

A. PV Cell

The relationship between the PV cell output current and terminal voltage according to the single-diode model is governed by equations.

$$I = I_{PV} - I_D$$

$$I_D = I_0 \left[\exp \left(\frac{q \cdot V}{n \cdot K \cdot T} \right) - 1 \right]$$

$$I_{PV} = \left[I_{SC} + K_i (T - T_{ref}) \right] \cdot \frac{G}{G_n}$$

where I_{pv} is the current generated by the incident light, I_0 is the reverse saturation current of the diode, q is the electro charge valued at 1.602×10^{-19} C, k is Boltzmann's constant valued at 1.381×10^{-23} J/K, T is the junction temperature in Kelvin, n is diode identity constant, V is the voltage across PV cell & I is the output current of the ideal PV model.

The proposed PSO algorithm will reinitialize the particles whenever the following condition as shown is satisfied:



International Journal of Advanced Research in Electrical, Electronics and Instrumentation Engineering

(An ISO 3297: 2007 Certified Organization)

Vol. 4, Issue 10, October 2015

$$\frac{|P_{PV,new} - P_{PV,last}|}{P_{PV,last}} \geq \Delta P(\%).$$

B. Buck Converter

As the duty cycle is equal to the ratio between the output and the input voltages and the period, it cannot be more than one ($V_o \leq V_i$). This is why this converter is referred to as step-down converter.

$$D = \frac{V_o}{V_i}$$

The inductor value can be calculated using the equation:

$$L = \frac{D(V_i - V_o)}{I_{ripple} * f_s}$$

The capacitor value can be calculated using the equation:

$$C = \frac{I_{ripple}}{8f_s * V}$$

where V_o represents output voltage, V_i represents input voltage, I_{ripple} represents ripple current (20% of maximum current).

C. DC Capacitor Link:

The DC capacitance is determined by the capacitor energy rate of change during transients and the rated active power. The calculation is proposed in:

$$C_{dc} = \frac{S_{rated}}{V_{dc}^2} \frac{2nT \Delta r \cos \phi}{\Delta x}$$

where T is the period of the AC voltage waveform, n is a multiple of T, Δr is the DC power range of change, in percent, during transients, and Δx is the allowable DC bus voltage range of change, in percent, during transients

IV. CODING FOR OPTIMIZATION

A PSO based PV system equivalent to 10 panels, is created, producing a power of 5kW which is connected to a buck converter that steps down the voltage of 170V to 20V. 20V is required by the battery bank, though the voltage rating of which is 12V. The battery used here is Lithium ion battery. The battery is followed by the inverter which effectively converts the dc power to ac to be utilized for the respective purposes. The LCL filter filters out the harmonics to create a sine wave. The filter is followed by step up transformer for stepping up the voltage value to 230V to be utilised by the grid.

The whole system is designed so as to provide an adequate power for lighting about 66 street lights throughout the night by using optimization where the available state of charge of the battery is enquired. Accordingly the lights that can be supplied by panels and from the grid is optimized out. Thus the consumers receive the lights throughout the night i.e. from 7pm to 6am. Time between 12am to 7pm is required for charging PV panels by using an effective PSO-based MPPT.

International Journal of Advanced Research in Electrical, Electronics and Instrumentation Engineering

(An ISO 3297: 2007 Certified Organization)

Vol. 4, Issue 10, October 2015

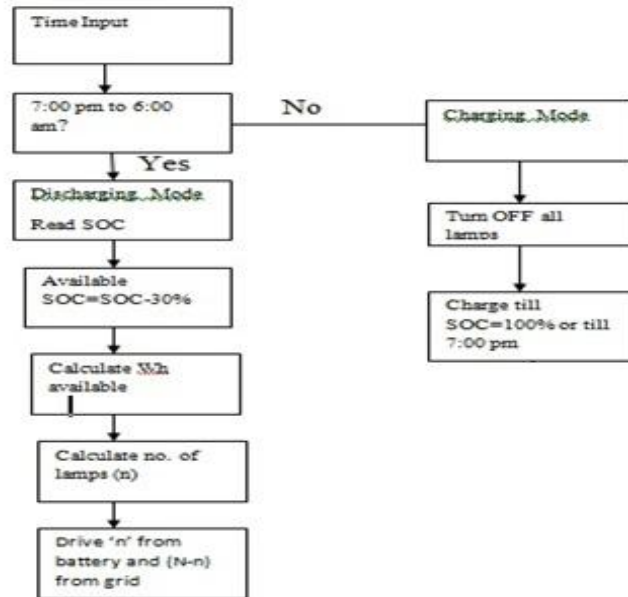

Fig.2 Coding for Optimization

V. RESULT AND DISCUSSION

The performance of the designed system is evaluated on the simple system using MATLAB/SIMULINK. The output voltage from the PV is 170V and the power obtained is 5kW. By using PSO in MPPT, the maximum power obtained is about 4kW. The model showing the system, the continuation of which is the combination of lights and mains are shown here:

CASE 1: DAY TIME (6am to 7pm)

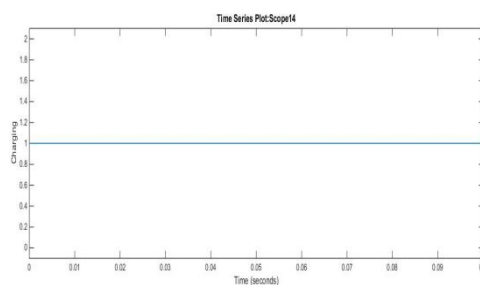

Fig.3 Charging of solar panels

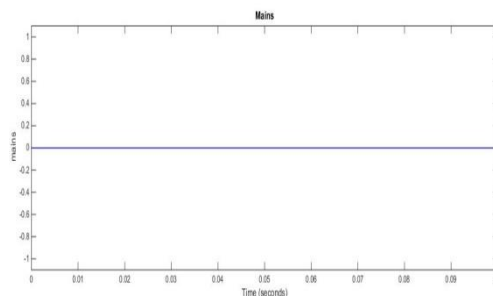

Fig.4 Mains Supply is OFF

International Journal of Advanced Research in Electrical, Electronics and Instrumentation Engineering

(An ISO 3297: 2007 Certified Organization)

Vol. 4, Issue 10, October 2015

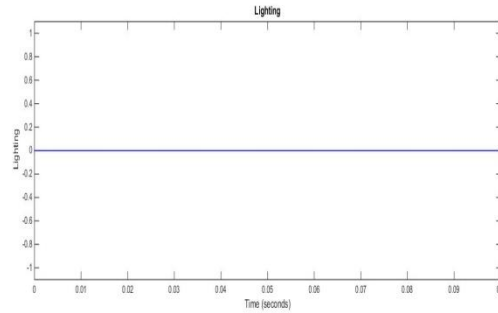

Fig.5 Lighting is ON

In figures 1,2 and 3, it shows the graphs of charging of solar panels, mains supply and no lighting of combination of lights.

CASE 2: NIGHT TIME(7pm to 6am)

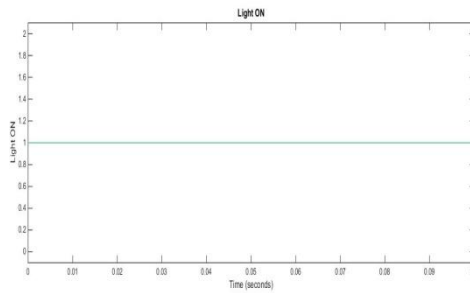

Fig.6 Lighting is ON

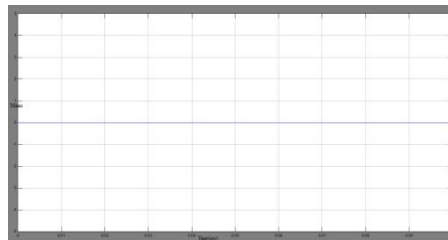

Fig.7 Mains supply OFF

OBSERVATIONS:

Battery State of Charge (%)	L1	L2	L3	L4	L5	L6	L7	L8	L9	L10	L11
60	1	1	1	0	0	0	0	0	0	0	0



International Journal of Advanced Research in Electrical, Electronics and Instrumentation Engineering

(An ISO 3297: 2007 Certified Organization)

Vol. 4, Issue 10, October 2015

70	1	1	1	1	0	0	0	0	0	0	0
90	1	1	1	1	1	0	0	0	0	0	0
99	1	1	1	1	1	1	1	0	0	0	0

Table.1 Different states of charge of batteries and the corresponding lighting status of combination of lights.

VI.CONCLUSION

The main purpose of this paper is to develop an accurate MPPT algorithm for centralized-type photovoltaic generation system operating even under partial shading condition. PSO is to meet the practical consideration of pgs operating under PSC. The whole system provides adequate power for lighting about 66 street lights throughout the night by using optimization where the available state of charge of the battery is enquired. Accordingly, the lights that can be supplied by panels and from the grid is optimized out. Hence the street lighting system is employed throughout the night and additional advantage of having reduction in cost. From the MATLAB/SIMULINK results, the operations on various conditions and the effective particle swarm optimization on the system becomes evident.

REFERENCES

- [1] Hugues Renaudineau Fabrizio Donatantonio, Julien Fontchastagner, Giovanni Petrone, Giovanni Spagnuolo, Jean-Philippe Martin, and Serge Pierfederici, "A PSO-based global MPPT technique for distributed PV power generation", IEEE Transactions on Industrial Electronics, Vol. 62, No. 2, February 2015.
- [2] Dian Palupi Rini, Siti Mariyam Shamsuddin, Siti Sophiyati Yuhani. "Particle Swarm Optimization: Technique, System and Challenges", IEEE journals on Computer Applications.
- [3] Liming Liu, Hui Li, Yaosuo Xse, Wenxin Liu, "Reactive Power Compensation and Optimization Strategy for Grid-Interactive Cascaded Photovoltaic Systems", IEEE Transactions on Power Electronics, Vol. 30, No. 1.
- [4] Bo Yang, Wuhua Li, Yi Zhao "Design and Analysis of a Grid-Connected Photovoltaic Power System", IEEE Transactions On Power Electronics, Vol. 25, No. 4, April 2010.
- [5] Liming Liu, Yaosue Xse, Wenxin Liu, "A Cascaded Photovoltaic System Integrating Segmented Energy Storages With Self-Regulating Power Allocation Control and Wide Range Reactive Power Compensation", IEEE Transactions On Power Electronics, Vol. 26, No. 12, December 2011.
- [6] Oke A. O., "Design and Construction of Solar Power-Based Lighting System", IJESRT, September 2013.
- [7] R. Poli, J. Kennedy, and T. Blackwell, "Particle swarm optimization—An overview," Swarm Intell., vol. 1, pp. 33–57, 2007.