



Reduction of Commutation Torque Ripple in Sensorless Brushless DC Motor Using Fuzzy Logic Controller

Nalini S¹, Natasha Thomas²

Assistant Professor, Dept of EEE, Dr Ambedkar Institute of Technology, Bangalore, Karnataka, India¹

PG Student [Power Electronics], Dept of EEE, Dr Ambedkar Institute of Technology, Bangalore, Karnataka, India²

ABSTRACT: Brushless Direct Current (BLDC) motors are widely used due to high reliability, simple frame, straight forward control, and low friction. BLDC motor has the advantage of high speed adjusting performance and power density. Speaking of the motor drive, the most important part is commutation control. On the other hand, they show a high torque ripple characteristics caused by nonideal commutation currents. This limits their application area especially for the low-voltage applications. In order to minimize torque ripple for the entire speed range, a comprehensive analysis of commutation torque ripple was made according to phase advancing(PA) commutation control method. This approach is based on the terminal voltage sensing and converting the voltages into d-q reference frame and the commutation signals are generated by comparing it with reference values. The gating signals are obtained by switching sequence of BLDC motor and it is done using fuzzy logic controller(FLC).The design analysis and simulation of the proposed system is done using MATLAB version 2013a and the simulation results of proportional- integral (PI) controller and fuzzy logic controller(FLC) method is compared.

KEYWORDS: Brushless DC motor, torque ripple, Phase advancing method, proportional integral controller, fuzzy logic controller.

I.INTRODUCTION

BRUSHLESS DC MOTOR (BLDCM) has been widely used in fields that require high reliability and precise control, due to its simple structure, high power density, high efficiency, high starting torque, long operating life and extended speeding range. BLDC motors are used in industries such as automotive, aerospace, consumer, industrial automation and instrumentation .As the name implies, BLDC motors do not use brushes for commutation, because BLDC motors are electronically commutated motor. BLDC motors have many advantages over brushed DC motors and induction motors. A brushless dc motor has high torque to weight ratio, increased reliability, reduced noise and reduction in electromagnetic interference as compared to brushed dc motor. In this paper we will be discussing primarily how the commutation torque ripple is being reduced by sensorless bldc motor using a fuzzy logic controller. Secondary in [1] commutation torque ripples according to three most common commutation control methods are analyzed and compared. Uses three commutation control methods for full speed range operation. Conventional six-step and phase-advancing (PA) methods are adopted below the base speed, and the phase-advancing with overlapping (PAO) method is used for over the base speed to obtain higher speed operation with low torque ripple. A hysteresis and deadbeat current control have been proposed to minimize the commutation torque ripple in [3]. Both methods use inner current control loops to regulate commutation current. In order to keep incoming and outgoing phase currents changing at the same rate during commutation, the duty cycle is regulated at low speed and the deadbeat current control is adopted at high speed. In [2] an overlapping technique, which extends the phase conduction period over 120 electrical degree, was adopted to reduce the torque spike by exciting a new conducting phase in advance. The direct torque control (DTC) scheme is suggested in [6]. The proposed DTC, however, needs arithmetic calculations for the extracting torque and flux compensation term that can add further computational overload to low cost CPUs. The duty ratio compensating torque fluctuation in PWM ON PWM method was discussed in [7]. This type of duty control, however, needs real-time measurements and calculation of phase current, angular position, and speed. In [5], a buck converter was used with a new modulation pattern to reduce the commutation torque ripple, but the bandwidth of the buck converter was not

International Journal of Advanced Research in Electrical, Electronics and Instrumentation Engineering

(An ISO 3297: 2007 Certified Organization)

Vol. 4, Issue 6, June 2015

considered, so this structure can only handle torque pulsation at the low speed. A super-lift Luo topology and SEPIC converter were employed in [9] and [8], respectively. But these structures need complex control or additional power switches

II. PROPOSED SYSTEM –TORQUE RIPPLE REDUCTION IN BLDC MOTOR USING FUZZY LOGIC CONTROLLER

A. System Configuration

For sensorless BLDC drive which is complex, multivariable and nonlinear, even if the plant model is well-known, there may be parameter variation problems. Figure 1 shows the circuit diagram of sensorless BLDC motor drive system. The BLDC motor is driven by a conventional three-phase inverter. DC power is supplied by rectifying the 3 phase ac supply. Control configuration shown is composed of a single-speed loop. Speed control output is directly fed to the PWM module as the duty ratio D, i.e., $D \in [0,1]$. The commutation detection block enables sensorless operation of the motor, comparing the measured back EMF with half dc-link voltage. The PWM duty is updated six times during an electrical period and maintained constant during a mode.

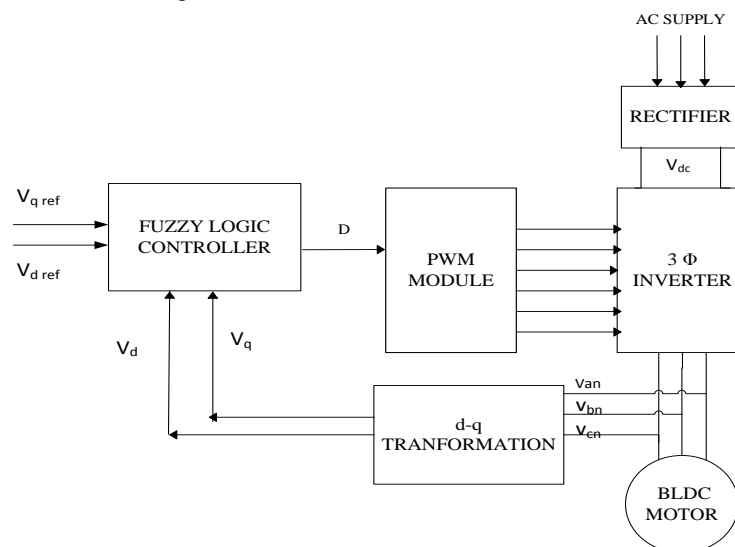

Fig. 1 Block diagram of sensorless Brushless DC motor drives system using Fuzzy Logic controller

The ripple contents of stator current, electromagnetic torque and rotor speed are minimized with FLC method. The advantages of Fuzzy Logic Controller is that it does not require any mathematical model and only based on the linguistic rules. The use of the d-q-0 reference frame for BLDCM is based on the fact that, in a three-phase Y-connected motor with non-sinusoidal air gap flux distribution, the d-q-0 transformation of the three line-to-line back EMF's results in the finding of the d- and q- components identical to those of three phase back EMF's transformation.

During start-up and other severe motoring operations, the motor draws large currents, produce voltage dips, oscillatory torques and can even generate harmonics in the power system. It is therefore important to be able to model the asynchronous machine in order to predict these phenomena. Various models have been developed and the q- d axis model for the study of transient behavior has been well tested and proven to be reliable and accurate. Fig. 2 Voltage waveforms according to the commutation control method i) line- to - lie back emf , ii) phase back emf, iii) switching function

The measured phase back EMF waveforms in natural a-b-c reference frame are transformed to the d-q-0 reference frame by using the equations.

$$\begin{bmatrix} e_d \\ e_q \\ e_o \end{bmatrix} = [C] \begin{bmatrix} e_a \\ e_b \\ e_c \end{bmatrix} \quad (1)$$

International Journal of Advanced Research in Electrical, Electronics and Instrumentation Engineering

(An ISO 3297: 2007 Certified Organization)

Vol. 4, Issue 6, June 2015

$$C = \frac{2}{3} \begin{bmatrix} \cos(\theta_e + \Phi) & \cos(\theta_e + \Phi - \frac{2\pi}{3}) & \cos(\theta_e + \Phi + \frac{2\pi}{3}) \\ \sin\theta_e & \sin(\theta_e + \Phi - \frac{2\pi}{3}) & \sin(\theta_e + \Phi + \frac{2\pi}{3}) \\ \frac{1}{2} & \frac{1}{2} & \frac{1}{2} \end{bmatrix}$$

where $\theta_e = \omega_e t$, ω_e is an electrical angular frequency and ϕ is an angular displacement between the stator current and rotor flux linkage and is generally equal to zero, and C is the transformation matrix of three phase to synchronously rotating d-q-0 reference frame.

B. Phase advancing method for commutation control: inverter topology and firing scheme

The CPA method uses the common three-phase, voltage-fed inverter (VFI) topology shown in Fig. 3 shows the motor model used for simulation.

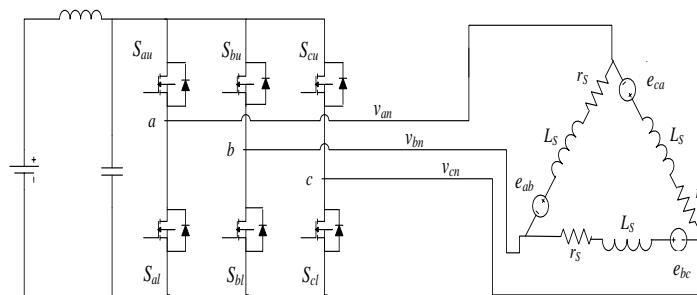

Fig.3 Common voltage-fed inverter topology and motor model

The bypass diodes of the common VFI make this configuration inherently capable of regeneration. This capability is desirable in the case of controlled regenerative braking, but it also has two undesirable consequences. If a fault develops in the dc supply, the motor will feed current into the fault so long as the permanent magnets continue to rotate. In addition, if the motor is operating at high speed, a loss of transistor firing signals will result in uncontrolled regenerative braking until the motor slows to the speed where the back emf magnitude drops below the level of the dc supply voltage. Guarding against the consequences of such failures would require additional components. Above base speed, the back emf exceeds the dc supply voltage and the firing must be advanced (i.e., a phase is energized during the transition portion of the back emf where the available dc supply voltage can drive current into the motor). In the vicinity of base speed, operation is a mixture of phase advance and current regulation. At a speed only slightly greater than base speed, the current regulation becomes ineffective and all the control is accomplished by phase advance. In this work we consider only speeds at which all control is achieved through phase advance. The phase B and C back emfs have the same shape but are delayed from phase A by 120° and 240°, respectively. The firing of phase B and C transistors is analogous but with the appropriate delays applied. The switching frequency during pure phase advance is at the fundamental electrical frequency consistent with motor speed. Pulse width modulation is not necessary. Transistor Q1 is fired θ_a degrees ahead of the instant that the phase A back emf, e_{an} , reaches its positive maximum. θ_a is called the “advance angle.” Transistor Q4 is fired θ_a degrees ahead of the instant that e_{an} reaches its most negative value. Although that can be varied from 0 to 60°, it is found that the limiting range is from -60 to +120°. An advance angle near 30°, the exact value being parameter and speed dependent, results in zero average power. An advance less than this value results in regenerative braking and a greater value results in motoring operation.

III. FUZZY LOGIC CONTROLLER

The Fuzzy Logic Controller initially converts the crisp error and change in error variables into fuzzy variables and then are mapped into linguistic labels. Membership functions are associated with each label as shown in which



International Journal of Advanced Research in Electrical, Electronics and Instrumentation Engineering

(An ISO 3297: 2007 Certified Organization)

Vol. 4, Issue 6, June 2015

consists of four inputs and four outputs. The inputs are V_q , V_d , V_{dref} , V_{qref} and the outputs are $error_vd(erVd)$, $error_vdref(erVrd)$, $error_vq(erVq)$, $error_vqref(erVrq)$.

Linguistic labels are divided into three groups:

- I. Small(S)
- II. Medium(M)
- III. Large(L)

TABLE I
 RULE MATRIX

INPUTS				OUTPUTS			
V_q	V_d	V_{qref}	V_{dref}	$errorVq$	$errorVd$	$errorVqref$	$errorVdref$
S	M	L	S	S	S	S	S
S	L	L	S	S	S	S	S
S	L	S	-	S	S	S	S
S	L	-	S	S	S	S	S
S	L	M	-	S	S	S	S
S	L	-	L	S	S	S	S
S	L	-	L	M	S	S	S
S	L	-	L	L	S	S	S
S	L	L	L	L	L	S	S
S	L	-	L	L	L	L	S
S	L	-	L	L	L	L	M
S	L	-	L	L	L	L	L
S	L	-	L	L	M	L	L
S	L	-	L	L	M	L	S
S	L	-	L	L	M	S	S
S	L	-	L	L	L	S	S
S	L	-	L	L	S	S	S
S	L	-	L	M	S	S	S

Each of the inputs and the output contain membership functions with all these three linguistics. Triangular function is used as membership function.

International Journal of Advanced Research in Electrical, Electronics and Instrumentation Engineering

(An ISO 3297: 2007 Certified Organization)

Vol. 4, Issue 6, June 2015

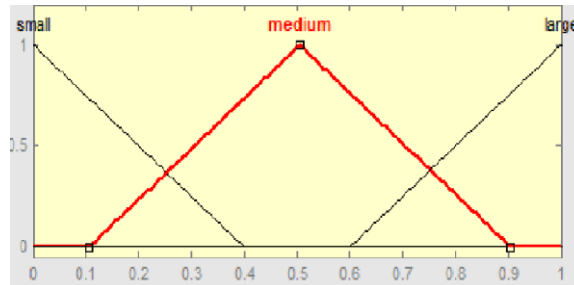

Fig.4 triangular membership functions used for the linguistic variables

The mapping of the fuzzy inputs into the required output is derived with the help of a rule base as given in Table II. There are four inputs and for outputs are framed to form 18 rules. The rules are formulated based on the parameters of the motor and the based on method to reduce the ripple content in torque. The output of the fuzzy controller block is derived as duty cycle which is fed to the PWM module. Thus the PWM module feed the inverter with required switching pattern.

TABLE II
 PARAMETERS OF BLDC MOTOR USED IN SIMULATION

RATED POWER	2.5 hp
RATED TORQUE	1.2 Nm
RATED VOLTAGE	300 V
RATED CURRENT	6 A
STATOR RESISTANCE	0.08Ω
INDUCTANCE L _s	1.15H
MAGNETIC FLUX	0.014 weber
NUMBER OF POLES	4
MOMENT OF INERTIA	0.08 kgm ²
RATED SPEED	1500rpm

IV. SIMULATION RESULTS

Simulation and experiments have been performed with parameters listed in Table II. Simulation studies were conducted and torque responses under various time ranges were observed. MATLAB version 2013a is used for simulation, using Fuzzy logic controller and Proportional Integral based torque controller and results were compared.

International Journal of Advanced Research in Electrical, Electronics and Instrumentation Engineering

(An ISO 3297: 2007 Certified Organization)

Vol. 4, Issue 6, June 2015

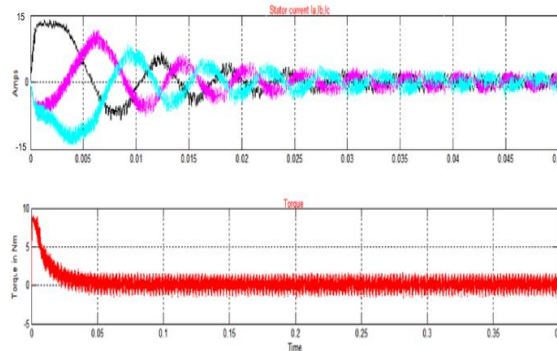

Fig. 5 shows the stator current and developed torque of BLDC motor under fuzzy logic controller

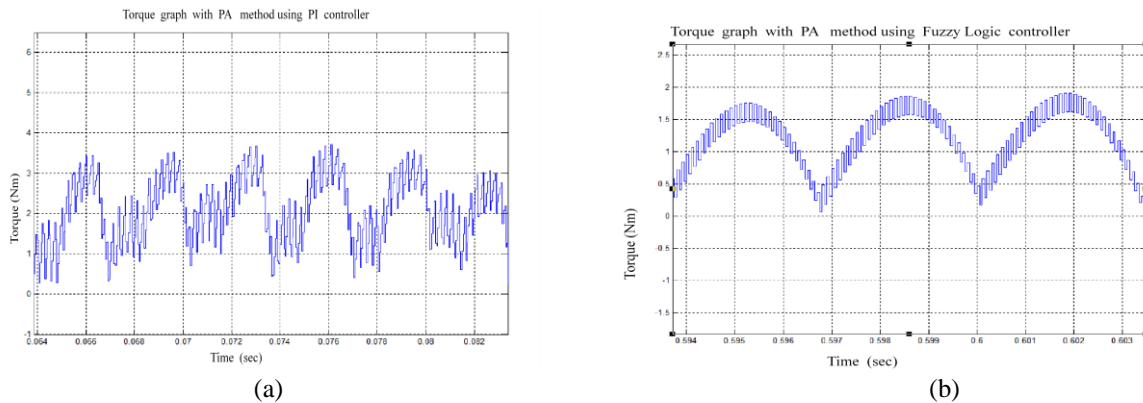

Fig.6 shows (a) Zoomed Torque output of BLDC motor with PA method using PI controller (b) Zoomed Torque output for BLDC motor driven by PA method using fuzzy logic controller

Figure 6 showed and proved that the torque ripple using PI controller was more than that of fuzzy logic controller

Waveforms of the phase currents at the start operation is shown in figure 5. The load torque of 1.2 Nm is applied when the motor was operating at 1500rpm for all cases. The magnitude of phase currents increases with PA for a fixed load torque because a part of the phase current is consumed to reduce the air-gap field, and thus the commutation current is increased. Measured torque waveforms are shown in Fig. 6, (a) and (b). The magnitudes of commutation torque ripples are compared in the both controllers, PI controller and Fuzzy Logic Controller. Note that in the Fig. 6(a), time(sec) is plotted in the X axis and Electromagnetic torque(Nm) is plotted in the Y axis. Percentage Torque ripple can be ratio of Peak to peak torque value to the rated torque .The rated torque is 1.2Nm. From the calculation,75.8% of torque ripple content is found when Proportional Integral controller is used. From Fig 6(b) the percentage of Torque ripple is calculated as 12.08%, when the Fuzzy Logic Controller is used. The comparative result shows that the torque ripple of the BLDC motor is reduced about 6 times in Fuzzy Controller method than PI controller method.

V. CONCLUSION

A control method aimed at reducing the commutation torque ripple of the BLDC motor controller have been simulated using MATLAB. Simulation studies were conducted to evaluate the performance of both proportional integral controller and fuzzy logic controller based torque ripple reduction method. The torque responses under various time ranges were observed. The comparative result shown that the torque ripple of the BLDC motor is reduced in Fuzzy controller method than PI controller method. So the performance of BLDC motor is improved in fuzzy logic controlled, Phase advancing method. It can be seen that there are less overshoots in the torque ripple from the fuzzy logic controller, as it is well tuned for sensorless control of Brushless DC motor for arious speed control



International Journal of Advanced Research in Electrical, Electronics and Instrumentation Engineering

(An ISO 3297: 2007 Certified Organization)

Vol. 4, Issue 6, June 2015

applications. Obtained results confirm the effectiveness of the proposed system under various speed ranges. This makes the motor suitable in applications such as fuel pump, robotics and industrial automation etc. The proposed torque ripple control scheme is robust, efficient and easy to implement.

REFERENCES

- [1] Sang Yong Jung, Yong Jae Kim, Jungmoon Jae, and Jaehong Kim, 'Commutation Control for the Low Commutation Torque Ripple in the Position Sensorless Drive of the Low Voltage Brushless DC Motor', IEEE Trans. Power Electron., vol. 29, no. 11, pp. 5983- 5993, Nov. 2014.
- [2] J.S.Lawler, J.M.Bailey, J. W. McKeever, and J.Pinto, 'Limitation of the conventional phase advance method for constant power operation of the brushless DC motor,' in Proc. IEEE Southeast Con, pp. 174–180,2002.
- [3] W.Chang hee, S.Joong Ho, and I. Choy, 'Commutation torque ripple reduction in brushless DC motor drives using a single DC current sensor', IEEE Trans. Power Electron., vol. 19, no. 2, pp. 985–990, Mar. 2004.
- [4] D.K.Kim, K.W.Lee, and B. I. Kwon, 'Commutation torque ripple reduction in a position sensorless brushless DC motor drive,' IEEE Trans. Power Electron., vol. 21, no. 6, pp. 1762–1768, Nov. 2006.
- [5] Z.Xiaofengand, L.Zhengyu, 'A new BLDC motor drives method based on buck converter for torque ripple reduction,' in Proc. IEEE Power Electron. Motion Contr., Conf., pp. 1–4,2006.
- [6] Y. Liu, Z. Q. Zhu, and D. Howe, "Commutation torque ripple minimization in direct torque controlled PM brushless DC drives', IEEE Trans. Ind. Appl., vol. 43, no. 4, pp. 1012–1021, Aug. 2007.
- [7] J. Fang, H. Li, and B. Han, 'Torque ripple reduction in BLDC torque motor with non ideal back EMF', IEEE Trans. Power Electron., vol. 27, no. 11, pp. 4630–4637, Nov.2012.
- [8] T.W. Chun, Q.V. Tran, H.H. Lee, and H.G. Kim, 'Sensorless control of BLDC motor drive for an automotive fuel pump using a hysteresis comparator,' IEEE Trans. Power Electron., vol.29,no.3, pp.1382–1391,Mar. 2014.
- [9] W. Chen, C. Xia, and M. Xue , 'A torque ripple suppression circuit for brushless DC motors based on power DC/DC converters', in Proc. IEEE Ind. Electron. Appl. Conf, pp. 1453–1457, 2008.