



Switching Control of Dual Active Bridge AC/DC Converter

Premkumar S^{1*}, Ramu.G², Gunasekaran.S³, Baskar.D⁴

Assistant Professor, Department of Electrical and Electronics Engineering, Bharath University, Chennai,
Tamil Nadu, India^{1*,2,3,4},

ABSTRACT: A switching control strategy to enable Zero-Voltage-Switching (ZVS) over the entire input-voltage interval and the full power range of a single-stage Dual Active Bridge (DAB) AC/DC converter is proposed. The converter topology consists of a DAB DC/DC converter, receiving a rectified AC line voltage via a rectifier. The DAB comprises primary and secondary side full bridges, linked by a high-frequency isolation transformer and inductor. In this paper full bridge to full bridge DAB setup, provide more flexibility to minimize rms current.

I. INTRODUCTION

Utility interfaced isolated AC/DC converters cover a widerange of applications such as power supplies in telecommunication and data centers , plug-in hybrid electrical vehicles (PHEVs) and battery electric vehicles (BEVs). Bidirectional functionality is increasingly required since the traditional electricity grid is evolving from a rather passive to a smart interactive service (customers/operators) where the traditional central control philosophy is shifting towards a more distributed control paradigm and where the energy systems play an active role in providing different types of support to the grid. In this area of grid-interfaced systems, Dual Active Bridge (DAB) converters seem to be a favorable choice for complying with future system requirements. [1-3]The biggest advantage of the DAB topologies is that the AC/DC energy conversions can take place in a single conversion stage, producing high quality waveforms and complying with future regulations on low and high frequency distortions of the mains AC power lines without the need for increasing the size and reactance value of the passive filter elements and for a separate front-end power factor correcting converter. Therefore a DAB DC/DC converter is used in combination with a synchronous rectifier, realizing a single-stage, bidirectional AC/DC power converter. The soft-switching DAB consists of two full bridges, interfaced by a high-frequency (HF) transformer, and was originally introduced in for realizing high-efficiency and high-powerdensity, isolated DC/DC conversions with the capability of buck-boost operation and bidirectional power flow. It was shown in that single-stage,unity power factor AC/DC conversions possible by combining the DAB DC/DC converter with a diode bridge rectifier or a more efficient synchronous rectifier (for bidirectional operation). When using conventional control strategies], the efficient soft-switching (ZVS) region of the DAB DC/DC converter is restricted by its voltage conversion ratio. Full-power-range soft-switching operation is only possible when this ratio is equal to one. However, when being used in an AC/DC setup, the input voltage of the DAB is a rectified sinewave, implying a variable voltage conversion ratio and restricted soft-switching operation. Recently we presented a pulse-width-modulation strategy to eliminate theseboundaries, allowing soft-switching operation over the entireinput sinewave interval and power range In this papers the analysis is extended towards a full bridge - full bridge DAB implementation, providing more flexibility to minimize the component RMS currents and allowing increased performance(in terms of efficiency and power density).

II.DUAL ACTIVE BRIDGE

Following figure 1 shows the schematic of the bidirectional,isolated DAB AC/DC converter topology.the rectified AC line voltage $v_{DC1}(t)$,coming from the synchronorus rectifier,is directly fed to the DAB DC/DC converter,putting a small high-frequency(HF) filter capacitor C_1 in between.The DAB comprises HF transformer coupled primary and secondary side full bridges,performing the DC output voltage(V_{DC2}) regulation while maintaining unity power factor at the AC side by actively waveshaping the line current $i_{DC1}(t)$.Therefore they produce phase shifted edge resonant square wave voltages $v_1(t)$ and $v_2(t)$ at the terminals of the HF AC-link(inductor L and HF transformer,resulting in an inductor

current $i_L(t)$. The objective of the project is soft-switching operation is allowed over the entire input sine wave interval by using the pulse width modulation strategy. To improve the quality of converter output current, a suitable efficient and cost effective ripple current filter design will also be developed. The two MOSFETs must be driven in a complimentary manner with a small dead time to avoid shoot through. [4-6]

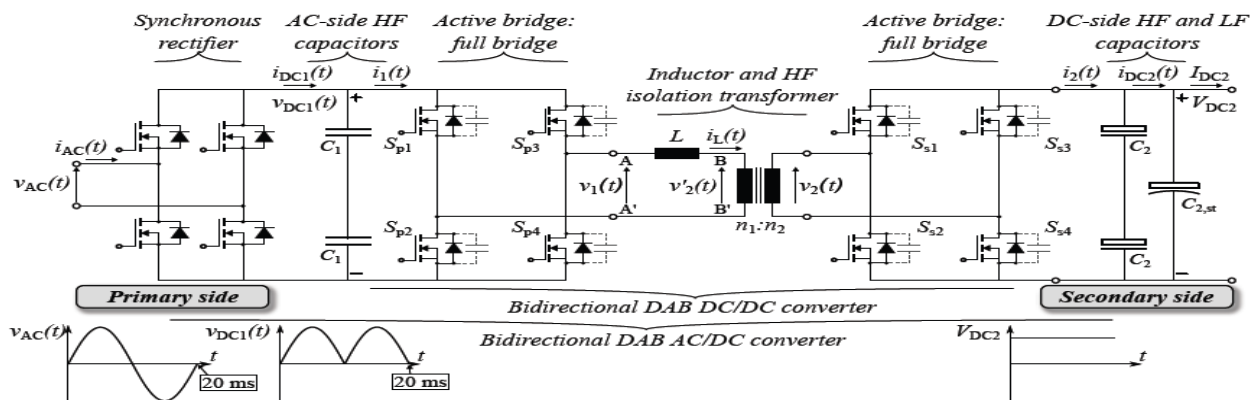

Fig.1 Bidirectional Dual Active Bridge AC/DC converter Topology

Both the active bridges act as AC/DC converters to their DC side, transforming the ac currents $i_1(t)$ into net DC currents $i_1(t)$ and $i_2(t)$ on the primary side and secondary side respectively. After passing HF filters C_1 and C_2 , DC currents $i_{DC1}(t)$ and $i_{DC2}(t)$ are obtained. These two currents can be phase aligned with $v_{DC1}(t)$ by proper control of the two active bridges, realizing the unity power factor:

$$i_{DC1}(t) = |I_{DC1} \sin(\omega L t)|$$

$$v_{DC1}(t) = |V_{DC1} \sin(\omega L t)|$$

with ωL the 50Hz AC line frequency. The voltages $v_1(t)$ and $v_2(t)$ generated by the active bridges are square waves with a duty cycle of $<50\%$. Inverter can be connected. [5]

Each high frequency switch S_{xx} is implemented by a power transistor T_{xx} , a diode D_{xx} , and a parasitic capacitor C_{xx} . Soft switching operation occurs when a voltage transition is initiated by turn off of the respective switch S_{xx} , commutating the current from the transistor T_{xx} to opposite diode D_{xx} of the leg. When this momentaneous resonant transition (quasi resonant ZVS) completes, T_{p2} is turned on under ZVS (anti-parallel diode is conducting). High voltage MOSFETs a minimum turn off commutation current of $I_{comm} > 2A$ is needed to recharge the parasitic drain to source capacitors within a 200ns dead-time interval, avoiding increased switching losses.

III. ISOLATION TRANSFORMER

This is a kind of transformer which supplies electricity to all equipments. [9] This helps in eliminating the couplings of two circuits and renders electricity from one to another circuit. These are generally suited for wide applicators. The noise between the secondary and primary windings is reduced in this transformer. These can be designed with either single phase or three phases. It is said that these transformer are the safest electronic which is used as a precaution for testing and servicing applications. This helps to forbid the influence in system from one section to another. These supply current to all device expect to the ground potential transformers. These can also be used for step up or step down current. These help in taking the alternating current from any source and then is fed without the electric connection of two circuits to other source

These are more utilized for sensitive equipments for power supply. That's because there is an electrostatic shield in the transformer. These are seen in laboratory units, telecommunication systems, Computer networking equipment, diagnostic testing and many more. These are also good for hospitals which also use sensitive equipments. The noise and power surges will damage the electronic equipment. But these can be protected only by using isolation transformer. These are one of the inexpensive transformers. These provides a lot of things like a complete isolation line, noise filter



International Journal of Advanced Research in Electrical, Electronics and Instrumentation Engineering

(An ISO 3297: 2007 Certified Organization)

Vol. 4, Issue 7, July 2015

which runs continuously an improved surge suppression mode and it also eliminates the risk of shock while using this equipment. These help in cutting down electrical surges even in the most atrocious power environments, which is useful for protecting the equipments.[6-8]

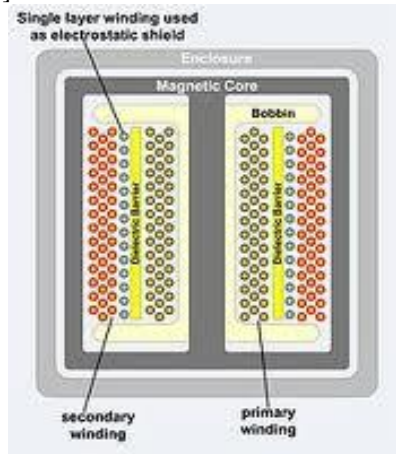

Fig.2 isolation transformer

PULSE WIDTH MODULATION

Output voltage from an inverter can also be adjusted by exercising a control within the inverter itself. The most efficient method of doing this is by pulse-width modulation control used within an inverter. [10-12]

In this method, a fixed dc input voltage is given to the inverter and a controlled ac output voltage is obtained by adjusting the on and off periods of the inverter components. This is the most popular method of controlling the output voltage and this method is termed as Pulse-Width Modulation (PWM) Control.

The advantages possessed by PWM techniques are as under:

- (i) The output voltage control with this method can be obtained without any additional components.
- (ii) With the method, lower order harmonics can be eliminated or minimized along with its output voltage control. As higher order harmonics can be filtered easily, the filtering requirements are minimized. [13]

The main disadvantage of this method is that SCRs are expensive as they must possess low turn-on and turn-off times. PWM inverters are quite popular in industrial applications. PWM techniques are characterized by constant amplitude pulses. The width of these pulses is however modulated to obtain inverter output voltage control and to reduce its harmonic content. The different PWM techniques are as under:

- (a) Single-pulse modulation
- (b) Multiple pulse modulations
- (c) Sinusoidal pulse width modulation (Carrier based Pulse Width Modulation Technique)

SINUSOIDAL PULSE WIDTH MODULATION

The switches in the voltage source inverter can be turned on and off as required.[14] In the simplest approach, the top switch is turned on If turned on and off only once in each cycle, a square wave waveform results. However, if turned on several times in a cycle an improved harmonic profile may be achieved. In the most straightforward implementation, generation of the desired output voltage is achieved by comparing the desired reference waveform (modulating signal) with a high-frequency triangular 'carrier' wave as depicted schematically in Fig. Depending on whether the signal voltage is larger or smaller than the carrier waveform, either the positive or negative dc bus voltage is applied at the output. Note that over the period of one triangle wave, the average voltage applied to the load is proportional to the amplitude of the signal (assumed constant) during this period. Notice that the root mean square value of the ac voltage waveform is still equal to the dc bus voltage, and hence the total harmonic distortion is not affected by the PWM process. The harmonic components are merely shifted into the higher frequency range and are automatically filtered due to inductances in the ac system. When the modulating signal is a sinusoid of amplitude A_m , and the amplitude of the triangular carrier is A_c , the ratio $m=A_m/A_c$ is known as the modulation index. Note that controlling the modulation



International Journal of Advanced Research in Electrical, Electronics and Instrumentation Engineering

(An ISO 3297: 2007 Certified Organization)

Vol. 4, Issue 7, July 2015

index therefore controls the amplitude of the applied output voltage. With a sufficiently high carrier frequency, the high frequency components do not propagate significantly in the ac network (or load). However, a higher carrier frequency does result in a larger number of switching's per cycle and hence in an increased power loss. Typically switching Frequencies in the 2-15 kHz range are considered adequate for power systems applications. Also in three-phase systems it is advisable to use so that all three waveforms are Symmetric

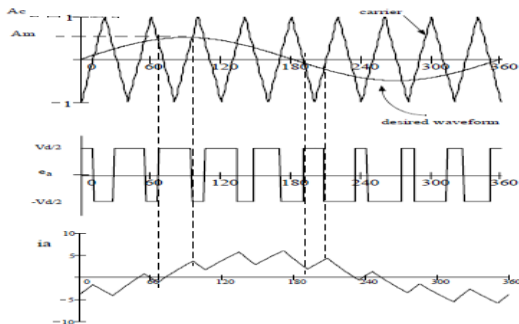

Fig.3 waveforms of SPWM

CIRCUIT OPERATIONS

Modes of operation

Mode I

The power flow will be from AC to DC

The switching sequences will be Positive half cycle following switches will conduct(turn on):

Sp1,Sp4,Ss3,Ss2

Negative half cycle following switches will conduct(turn on)

Sp3,Sp2,Ss1,Ss4

Mode II

The power flow will be from DC to AC

The switching sequences will be Positive half cycle following switches will conduct(turn on):

Ss1,Ss4,Sp3,Ss2

Negative half cycle following switches will conduct(turn on)

Ss3,Ss2,Sp1,Sp4

IV.SIMULATION RESULTS

MATLAB is an interactive system whose basic data element is an array that does not require dimensioning. This allows you to solve many technical computing problems, especially those with matrix and vector formulations, in a fraction of the time it would take to write a program in a scalar non interactive language such as C or FORTRAN.

SimPowerSystems and other products of the Physical Modeling product family work together with Simulink® to model electrical, mechanical, and control systems. SimPower Systems operates in the Simulink environment. Therefore, before starting this user's guide, you should be familiar with Simulink. For help with Simulink, see the Simulink documentation Or, if you apply Simulink to signal processing and communications tasks (as opposed to control system design tasks), see the Signal Processing Block set documentation

Simulink uses MATLAB as its computational engine, designers can also use MATLAB toolboxes and Simulink block sets. Sim Power Systems and Sim Mechanics share a special Physical Modeling block and connection line interface.

International Journal of Advanced Research in Electrical, Electronics and Instrumentation Engineering

(An ISO 3297: 2007 Certified Organization)

Vol. 4, Issue 7, July 2015

A. BIDIRECTIONAL AC/DC CONVERTER CIRCUIT DIAGRAM (MODE I) MODE I-AC TO DC

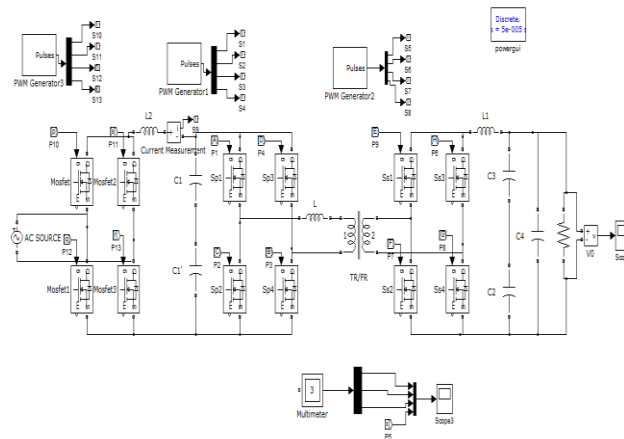

Fig.4 Simulation Diagram of bidirectional AC/DC converter

INPUT VOLTAGE WAVEFORM

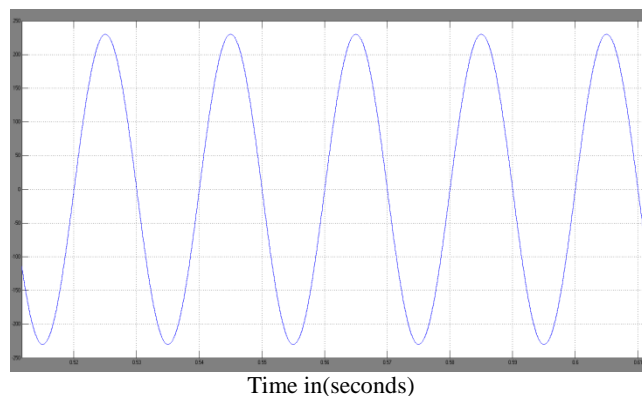

Fig.5 Input voltage waveform

Figure 5 shows the simulated input voltage, which is measured across the input side by connecting a voltage measurement with scope. $V_{in}=230V$.

OUTPUT VOLTAGE WAVEFORM

Figure.6 shows the simulated output voltage, which is measured across the output side by connecting a voltage measurement with scope. $V_{out}=260V$.



International Journal of Advanced Research in Electrical, Electronics and Instrumentation Engineering

(An ISO 3297: 2007 Certified Organization)

Vol. 4, Issue 7, July 2015

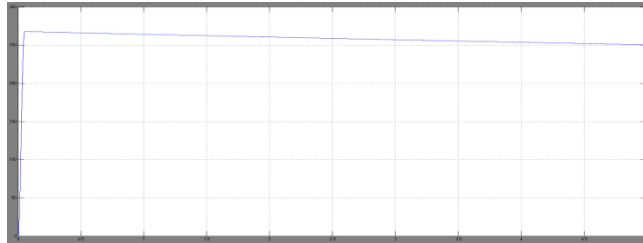

Time in(seconds)
Fig.6 output voltage waveform

CIRCUIT PARAMETERS

Figure.7 shows the simulated inductor current(I(L)),primary and secondary side voltages(v1&v2),input DC current(i1) by connecting scope

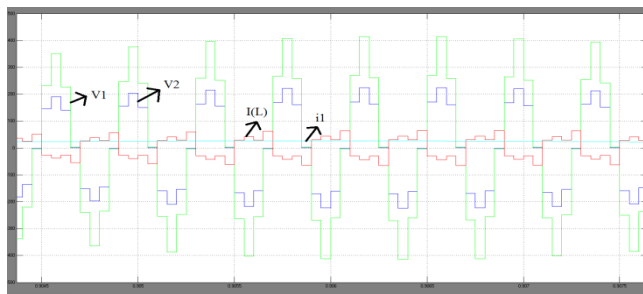

Time in(seconds)
Fig.7 circuit parameters

Where the parameters are $V_1=230v$, $I(L)=50A$, $V_2=400v$, $i_1=25A$

B. BIDIRECTIONAL AC/DC CONVERTER CIRCUIT DIAGRAM (MODE II)

MODE II- DC TO AC

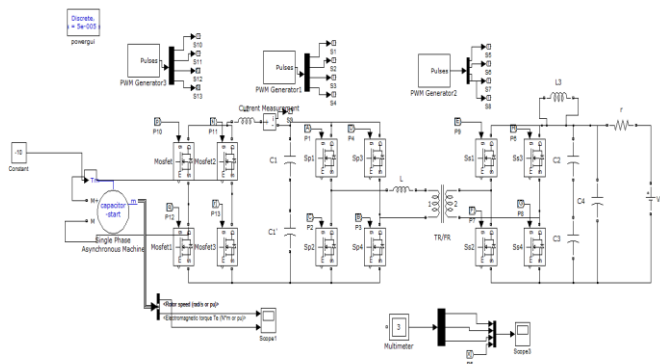

Fig.8 Simulation Diagram of bidirectional AC/DC converter



International Journal of Advanced Research in Electrical, Electronics and Instrumentation Engineering

(An ISO 3297: 2007 Certified Organization)

Vol. 4, Issue 7, July 2015

INPUT VOLTAGE WAVEFORM

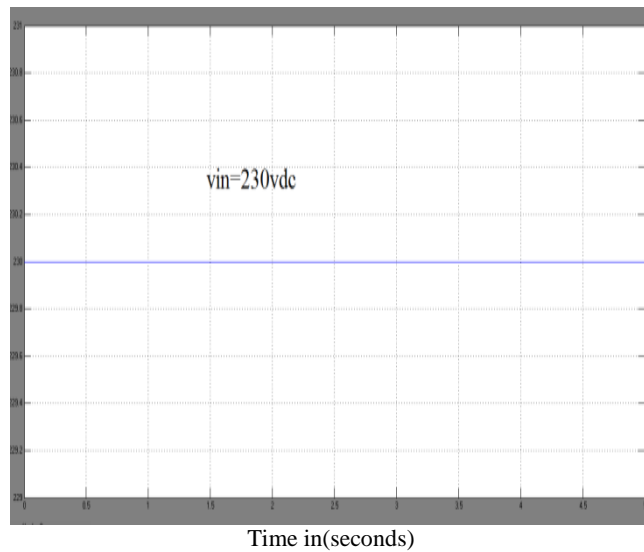

Figure 9 shows the simulated input voltage, which is measured across the input side by connecting a voltage measurement with scope. $V_{in}=230V$.

CIRCUIT PARAMETERS

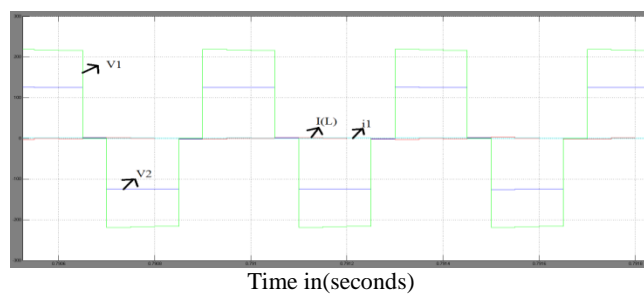

Figure.10 shows the simulated inductor current($I(L)$),primary and secondary side voltages($v1$ & $v2$),input DC current($i1$) by connecting scope

Where the parameters are $V1=230V$, $I(L)=50A$, $V2=150V$, $i1=40A$

Motor torque $Torque=25N/m$



International Journal of Advanced Research in Electrical, Electronics and Instrumentation Engineering

(An ISO 3297: 2007 Certified Organization)

Vol. 4, Issue 7, July 2015

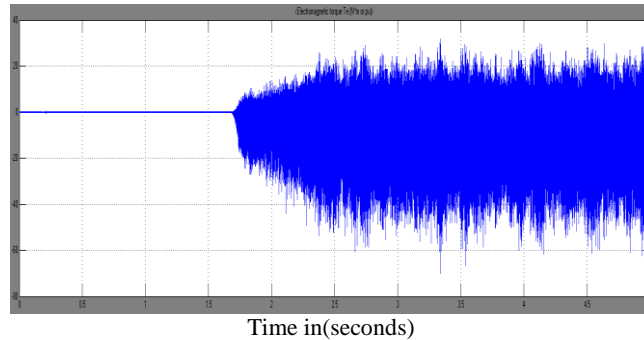

Fig.11 Result of motor torque

Figure 11 shows the simulated torque, which is measured across motor by connecting a torque measurement with scope

Motor speed Speed=7rad/sec

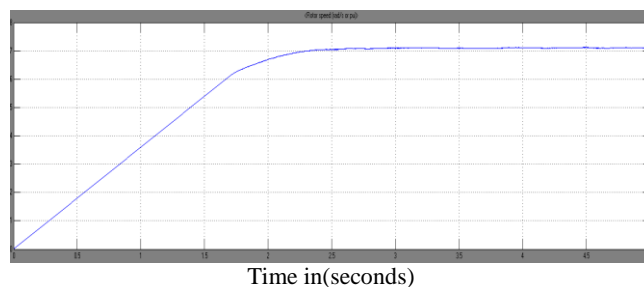

Fig.12 Result of motor speed

Figure 12 shows the simulated speed, which is measured across motor by connecting a speed measurement with scope

V. CONCLUSION

A switching control strategy to enable soft-switching operation of a full bridge - full bridge DAB AC/DC converter in the entire input sine wave interval and full power range is presented. An analysis of the possible switching modes is provided from which a selection of two “most feasible” modes is made. The final switching control strategy combines these two modes in an appropriate way in order to achieve full soft switching AC/DC operation and unity power factor. It is shown that both activebridges can operate with a finite commutation current, enhancing the resonant transition at transistor turnoff. Hereby the magnetizing inductance of the transformer is used to facilitate commutation current in the secondary bridge. This, together with the promising results obtained from a comprehensive system comparison, makes the single - stage full bridge-full bridge DAB a feasible solution for isolated, bidirectional AC/DC applications. In future the prototype model of a proposed , bidirectional AC/DC is to be implemented in hardware and the results are analyzed.

REFERENCES

- [1] A. Stupar, T. Friedli, J. Miniböck, M. Schweizer, and J. W. Kolar, “Towards a 99% Efficient Three-Phase Buck-Type PFC Rectifier for 400V DC Distribution Systems,” in IEEE 26th Applied Power Electronics Conference and Exposition (APEC 2011), March 2011, pp. 505–512.
- [2] Subha Palaneeswari M., Abraham Sam Rajan P.M., Silambanan S., Jothimalar, "Blood lead in end-stage renal disease (ESRD) patients who were on maintenance haemodialysis", Journal of Clinical and Diagnostic Research, ISSN : 0973 - 709X, 6(10) (2012) pp.1633-1635.
- [3] Sharmila S., Rebecca L.J., Saduzzaman M., "Effect of plant extracts on the treatment of paint industry effluent", International Journal of Pharma and Bio Sciences, ISSN : 0975-6299, 4(3) (2013) pp.B678-B686.



ISSN (Print) : 2320 – 3765
ISSN (Online): 2278 – 8875

International Journal of Advanced Research in Electrical, Electronics and Instrumentation Engineering

(An ISO 3297: 2007 Certified Organization)

Vol. 4, Issue 7, July 2015

- [4] A. Pratt, P. Kumar, and T. V. Aldridge, "Evaluation of 400 V DC Distribution in Telco and Data Centers to Improve Energy Efficiency," in 29th International Telecommunications Energy Conference (INTELEC2007), Oct. 2007, pp. 32–39.
- [5] A. Matsumoto, A. Fukui, T. Takeda, and M. Yamasaki, "Development of 400-Vdc Output Rectifier for 400-Vdc Power Distribution System in Telecom Sites and Data Centers," in 32nd International Telecommunications Energy Conference (INTELEC 2010), June 2010, pp. 1–6.
- [6] A. Emadi, S. S. Williamson, and A. Khaligh, "Power Electronics Intensive Solutions for Advanced Electric, Hybrid Electric, and Fuel Cell Vehicular Power Systems," IEEE Transactions on Power Electronics, vol. 21, no. 3, pp. 567–577, May 2006.
- [7] Jeyanthi Rebecca L., Dhanalakshmi V., Sharmila S., "Effect of the extract of Ulva sp on pathogenic microorganisms", Journal of Chemical and Pharmaceutical Research, ISSN : 0975 – 7384 , 4(11) (2012) pp.4875-4878.
- [8] Sharmila D., Saravanan S., "Efficacy of lead on germination growth and morphological studies of Horse Gram (*Dolichos biflorus* Linn)", Journal of Chemical and Pharmaceutical Research, ISSN : 0975 – 7384 , 4(11) (2012) pp.4894-4896.
- [9] K. Clement-Nyns, E. Haesen, and J. Driesen, "The Impact of Vehicle-to-Grid on the Distribution Grid," Electric Power Systems Research, vol. 81, no. 1, pp. 185–192, 2011.
- [10] Directorate-General for Research and Innovation, European Commission.(2005) Towards Smart Power Networks, Lessons Learned from European Research FP5 Projects.
- [11] R. W. De Doncker, D. M. Divan, and M. H. Kheraluwala, "A Three-Phase Soft-Switched High Power Density DC/DC Converter for High Power Applications," in IEEE Industry Applications Society Annual Meeting,
- [12] Saduzaman M., Sharmila S., Jeyanthi Rebecca L., "Efficacy of leaf extract of *Moringa oleifera* in treating domestic effluent", Journal of Chemical and Pharmaceutical Research, ISSN : 0975 – 7384 , 5(2) (2013) pp.139-143.
- [13] Lingeswaran, K., "Microcontroller-based MPPT control for standalone PV system with sepic converter", Middle - East Journal of Scientific Research, v-20, i-8, pp:945-950, 2014.
- [14] Thamarai, P., Karthik, B., Kumaran, E.B., "Optimizing 2:1 MUX for low power design using adiabatic logic", Middle - East Journal of Scientific Research, v-20, i-10, pp:1322-1326, 2014.
- [15] Jayalakshmi, V., "Wireless sensor network for performance monitoring of electrical machine", Middle - East Journal of Scientific Research, v-20, i-8, pp:996-999, 2014.
- [16] Prasad, K.S., "A design towards smart batteries", Middle - East Journal of Scientific Research, v-20, i-10, pp:1318-1321, 2014.
- [17] Vijayaragavan, S.P., Karthik, B., Kiran Kumar, T.V.U., "Privacy conscious screening framework for frequently moving objects", Middle - East Journal of Scientific Research, v-20, i-8, pp:1000-1005, 2014.